

RUNDFLEX

Adjustable circular formwork
for radii greater than 1.00 m

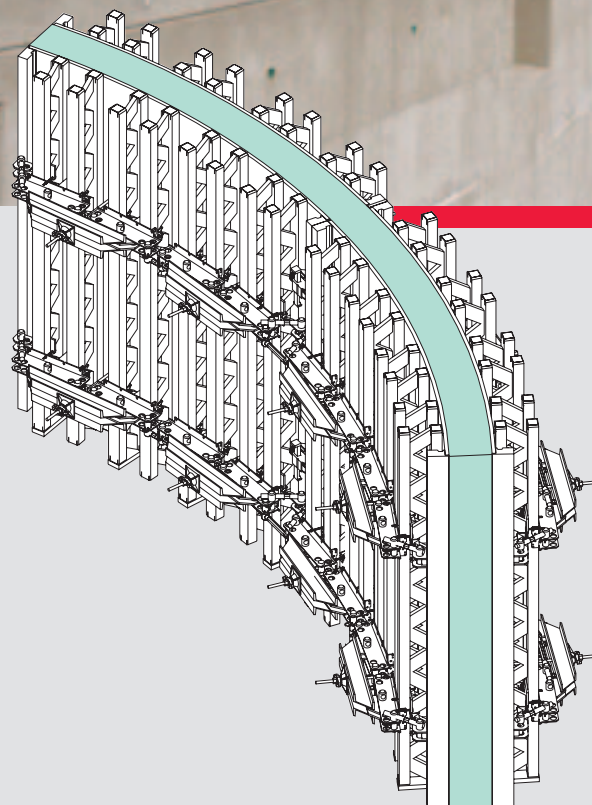

Edition 09/2009

PERI GmbH
Formwork Scaffolding Engineering

P.O. Box 1264

89259 Weissenhorn

Germany

Tel +49 (0)73 09.9 50-0

Fax +49 (0)73 09.9 51-0

info@peri.com

www.peri.com

Important Notes:

Without exception, all current safety regulations must be observed in those countries where our products are used.

The illustrations in this brochure are photographs of real site situations. Safety or formwork anchor details are therefore not to be taken as a definitive guide to the way the equipment is to be used.

Safety instructions and load specifications are to be strictly observed at all times. Separate structural calculations are required for any deviations from the standard design data.

The information contained herein is subject to technical changes in the interests of progress. Errors and typographical mistakes reserved.

Content

- 2 Which circular formwork should be used?
PERI offers different systems
- 4 Forming circular walls with a radius of more than
1.00 m without dismantling and reassembly of
panels
- 6 For complex geometries and special applications
- 8 For architectural concrete
- 10 Panels with continuously adjustable radii
- 11 Extensions
- 12 Fast and simple setting of the radii
- 13 Panel connections
- 14 Tables
- 17 Safety instructions
- 18 Components
- 28 PERI International

Which circular formwork should be used?

PERI offers different systems

RUNDFLEX for radii more than 1.00 m

- Pre-assembled elements.
- Adaptable to all radii.
- Modular system with tailored panel heights and widths.

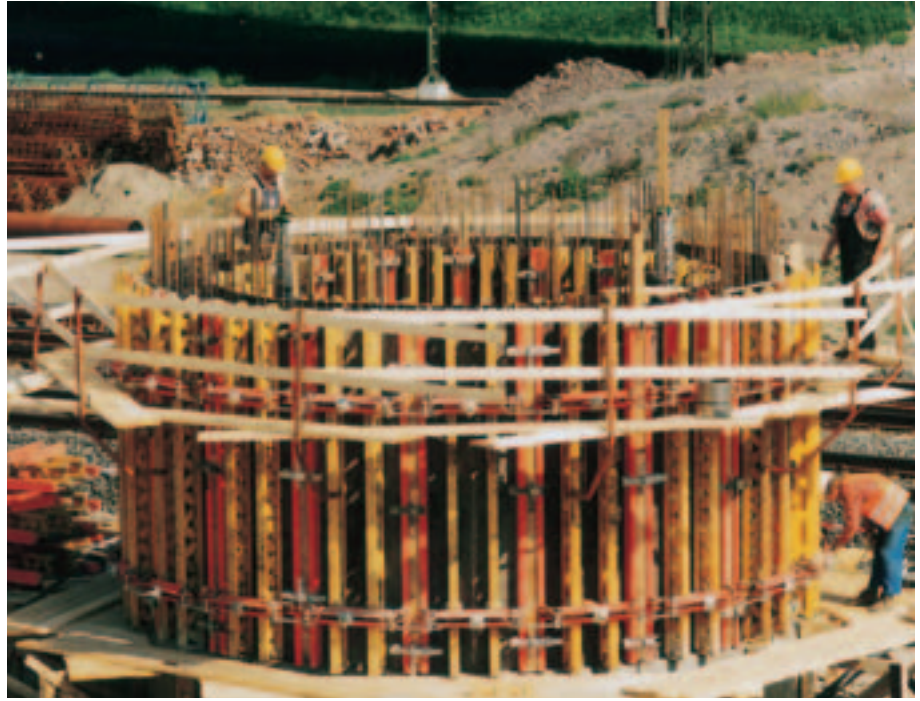

GRV circular formwork without ties

- Functions with closed formwork rings without ties.
- Waler positions carry tension and compression forces.
- Spindle waler for compensations.
- Cost-effective special solutions.



VARIO GT 24 Girder Wall Formwork

- Project-related element assembly i.e. panels are customised with regard to radius, concreting heights and transportation widths, and assembled according to jobsite requirements.
- Cost-effective alternative for unchanging radii and longer construction projects.



MAXIMO, TRIO, DOMINO Panel Formwork

- Polygonal circular formwork with standard panels.
- Also usable for smaller radii.

Special Steel Formwork

- For high utilisation rates and unchanging radii.



RUNDFLEX

Forming circular walls with a radius of more than 1.00 m without time-consuming dismantling and reassembly of panels



For the construction of sewage plants, spiral ramps for multi-storey car parks, oriels, silos and other circular structures, many different curvature types are required.

With fixed radii formwork panels, low utilisation rates are standard. Assembly, modifications or reassembly of the panels thus determine the amount of materials required as well as the costs involved.

PERI RUNDFLEX solves this problem through standard panels and without any time-consuming unit modifications.

Simple radii adjustment

The pre-assembled elements can be quickly adapted to changes in the radii with minimum of effort allowing frequent use in any location.

The self-cleaning adjusting spindles – and therefore the formwork itself – are adjusted to fit the required curvature by means of a ratchet spanner.

Construction of sewage plant facilities with different radii using 3.60 m high RUNDFLEX formwork.



High permissible concrete pressure
 RUNDFLEX is designed for a concrete pressure of 60 kN/m². This allows fast concreting to be carried out.

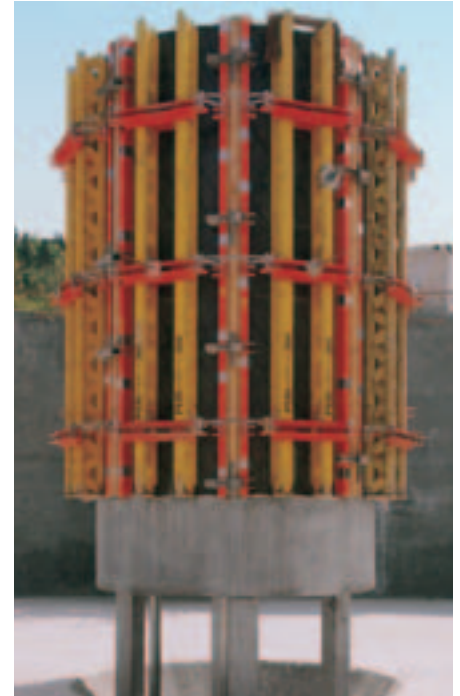

A pivot bearing for a sewage treatment tank with a radius of 1.10 m formed with RUNDFLEX A 85 and I 72 panels.

Standard RUNDFLEX elements extended to 11.40 m for construction of an administration building in Munich.



RUNDFLEX panels on KG climbing scaffold for construction of a spiral ramp at a new car dealership.

RUNDFLEX

For complex geometries and special applications

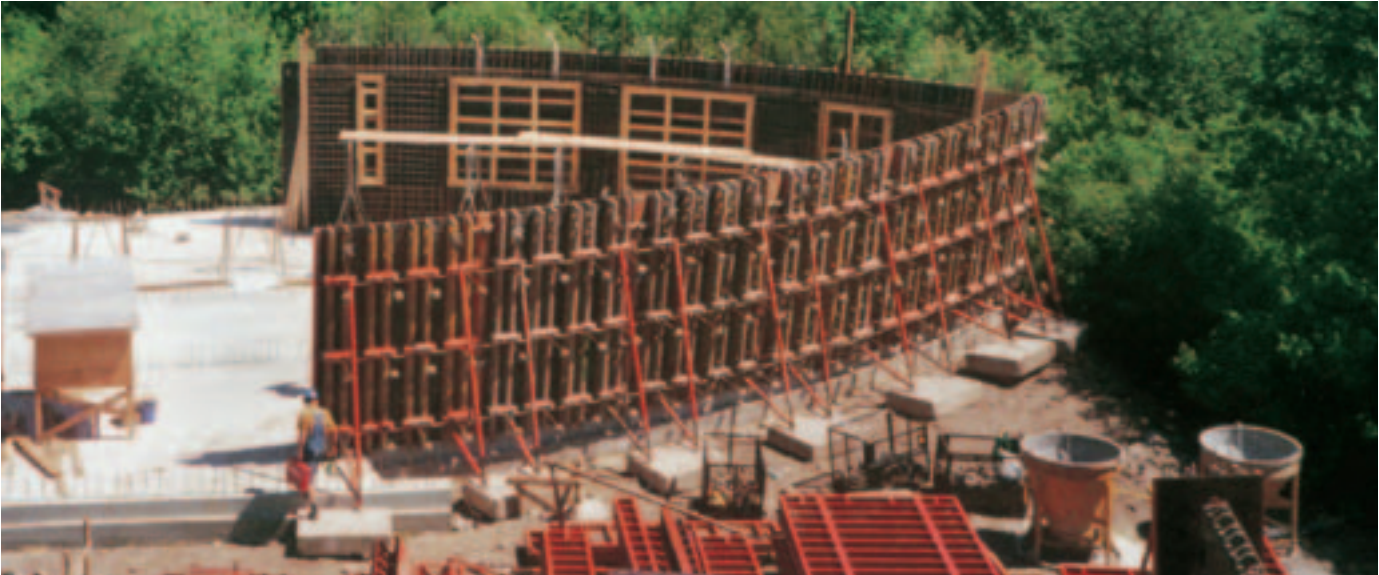

RUNDFLEX for the construction of a hull-shaped guest house. Constantly changing radii could be tackled problem-free.

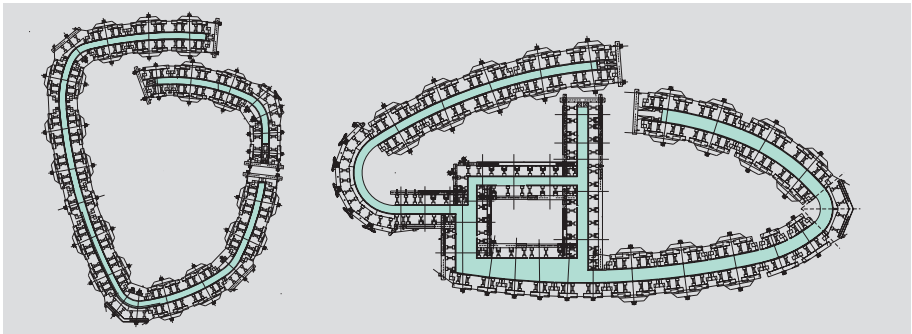

Through the combination of different formwork systems, the complicated ground plan of this office building could also be cost-effectively formed.

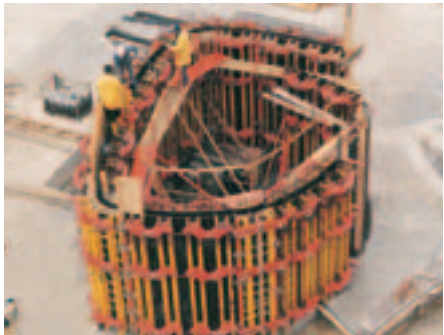
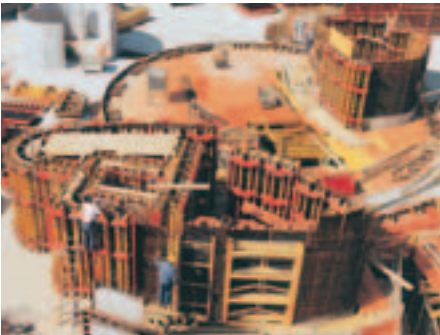



“Horizontally” positioned RUNDFLEX for the forming of an arched slab for a culture centre in Berlin.

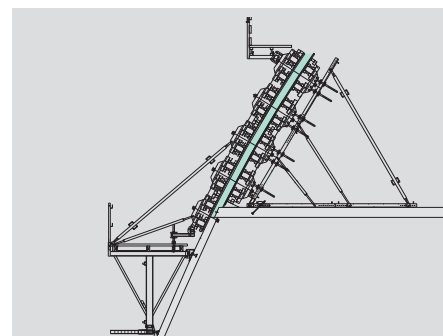

Spindle core and parapet of a spiral ramp for a multi-storey car park. Simple radii adjustment with the self-cleaning hexagonal spindle.



Elliptical-shaped tunnel portal with RUNDFLEX panels and accessories from the VARIO programme. The problem of constantly changing radii and inclination was solved by means of conically-cut filler timbers.



RUNDFLEX

For architectural concrete



Sewage works

6.00 m high, extended RUNDFLEX panels for the construction of a sewage treatment plant. Visibly remaining surfaces on the outer side with double board structure. Watertight tie positions using the DK tie system.

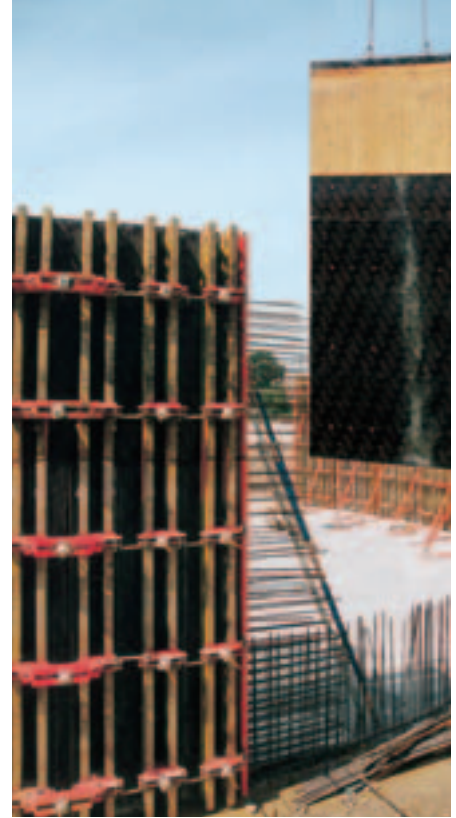

Car Park

Architectural concrete with an orderly tie and joint arrangement was required for this multi-storey car park. On the outer wall, the elements were climbed on FB 180 folding platforms and on the core using KG 180 climbing scaffold.



Music pavilion

A geometrically demanding structure included very high requirements concerning the concrete finish. Two opposing walls with radii from 4.62 m up to 6.21 m and heights ranging from 1.10 m to 4.33 m had to be formed. At the same time, the walls were inclined up to 9° inwards and 6° outwards. Conical compensation timbers and the adjustable RUNDFLEX formwork ensured that this challenging task was smoothly carried out.

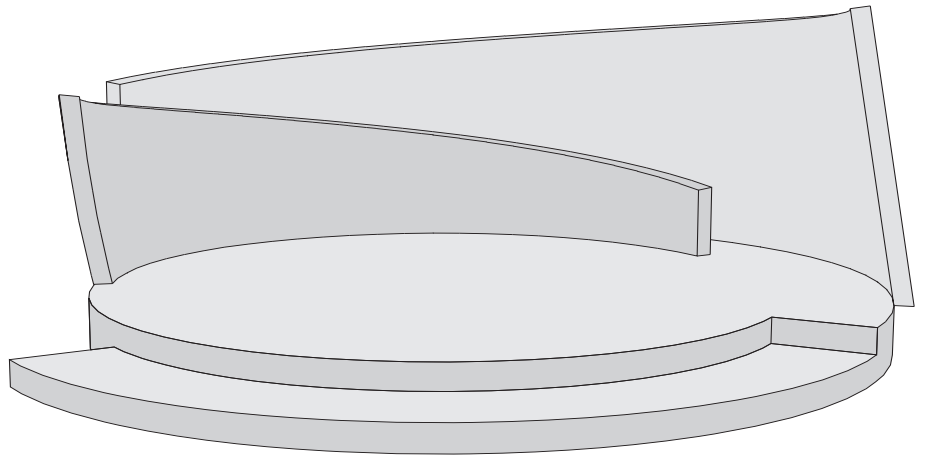

Museum

Impeccably-finished architectural concrete and quick adjustment to the different radii. Additional vertical distribution walers allowed the tie arrangement.

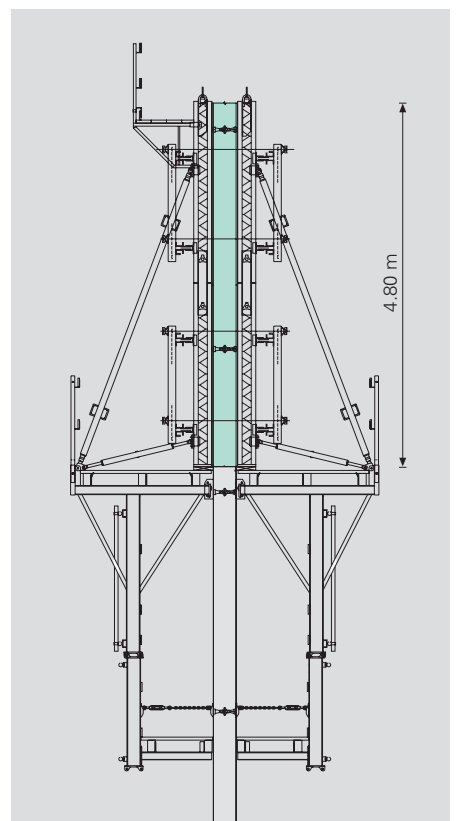

RUNDFLEX

Panels with continuously adjustable radii

PERI RUNDFLEX is available in 3 different panel widths and 6 heights.

In order to reduce transportation space to a minimum, elements are bundled together at the production facilities in a straight form and then adjusted on the construction site to suit the required radius.

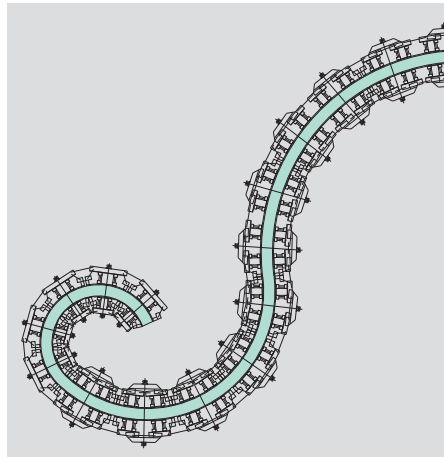

Complicated geometries with constantly changing radii are also quickly and easily formed using RUNDFLEX.

Elements for radii ≥ 4.00 m
Plywood: 21 mm

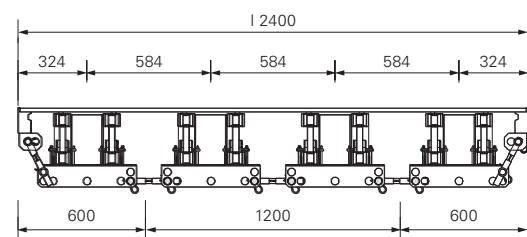
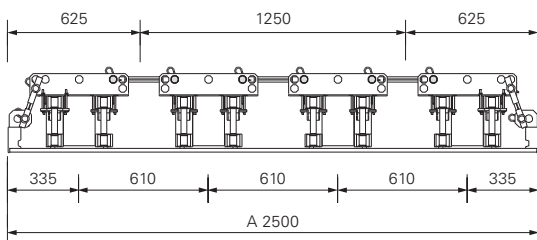

– for radii ≥ 2.50 m
Plywood: 18 mm

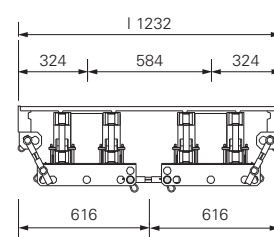
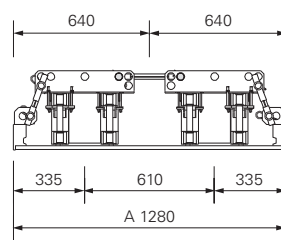

– for radii ≥ 1.00 m
Plywood: 2 x 9 mm

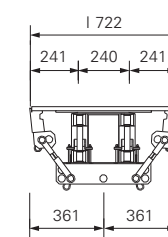
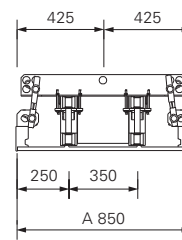

Extensions

PERI RUNDFLEX elements can be extended in 60 cm increments.

The elements can be extended horizontally or vertically. One Extension Splice 24-2 is always fitted to each girder joint.

Assembly is carried out on the ground:

- Position the elements.
- Insert splices into the lattice of the girders.
- Tighten three-winged nuts by tapping with a hammer.

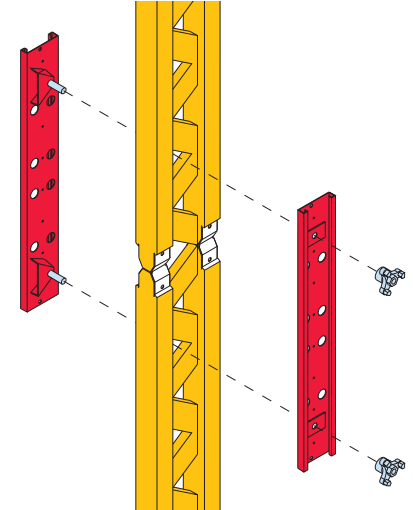

Note:

Extended RUNDFLEX panels may only be erected in one piece up to a height of 7.80 m. If transported vertically, higher units can also be moved.

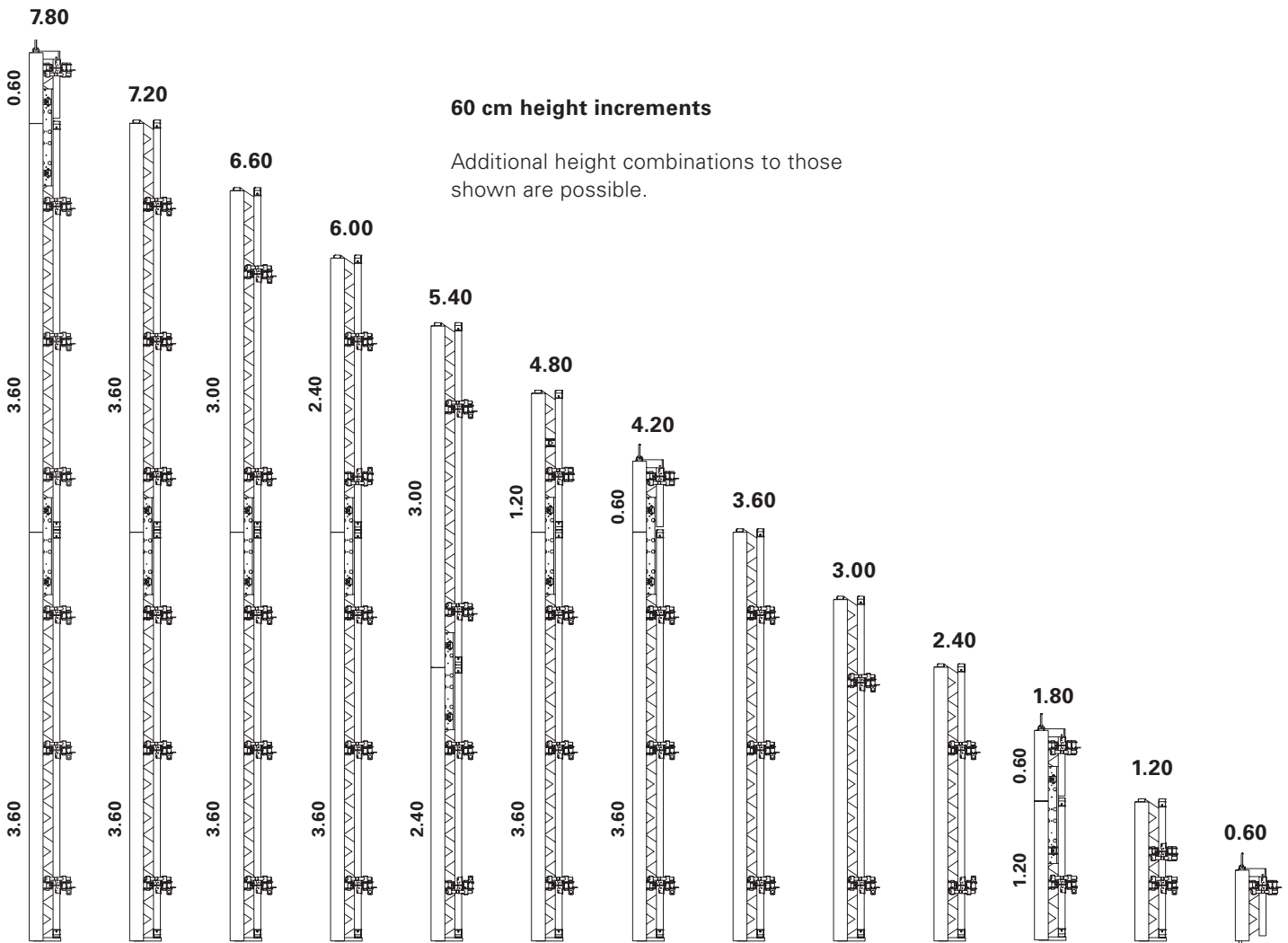

60 cm height increments

Additional height combinations to those shown are possible.

RUNDFLEX

Fast and simple setting of the radii

Always work in pairs in order to achieve an even and uniform curvature quickly.

Radii adjustment basically begins with the spindles in the middle of the panel and then work outwards in a uniform sequence.

Install the adjustable spindles with the yellow chromated parts always facing the same direction.

Advantage: faster adjusting procedure due to the same turning direction.

Pre-cut radii templates are available from PERI.



Checking the required curvatures is carried out by placing the radius template on the formwork girders.



The "combi" ratchet spanner is used on the Adjustable Spindle 210 to adjust the edge profiles.

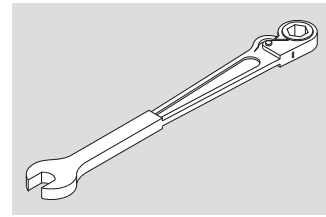

The "combi" ratchet spanner SW 24 (item no. 021790) for quick adjustment of RUNDFLEX elements.

Guidelines for constructing a radius template

For external formwork

= radius of concrete + 26.5 cm
(for 21 mm plywood thickness and 4 mm formlining strip on GT 24 girders).

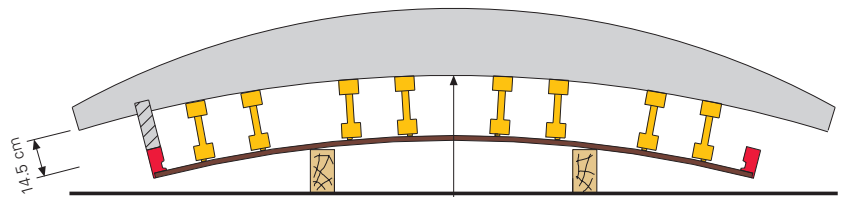

Radius template for
A 250/l 240, A 128/l 123
Item no. 099540

Ra = radius of concrete + 26.5 cm

Radius template for
A 85/l 72
Item no. 098217

Ri = radius of concrete - 26.5 cm

For internal formwork

= radius of concrete - 26.5 cm
(for 21 mm plywood thickness and 4 mm formlining strip on GT 24 girders).

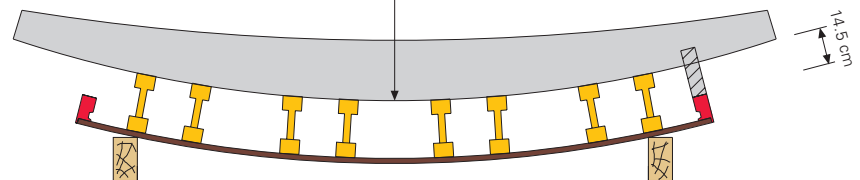

Panel connections

When connecting the elements, make sure that the elements (external and internal) are aligned on their axis.

Place filler timbers, up to a max. 10 cm wide, between the external and internal elements according to design table requirements. It may be necessary to cut compensation walers to a taper for smaller radii.

When using I 72 panels for a radius less than 2.10 m and a wall thickness of 25 cm, Adjusting Spindles 210 must be used on panel joints.



Adjusting Spindles 500 positioned in the T-waler and secured by means of Cotter Pins 5/1.

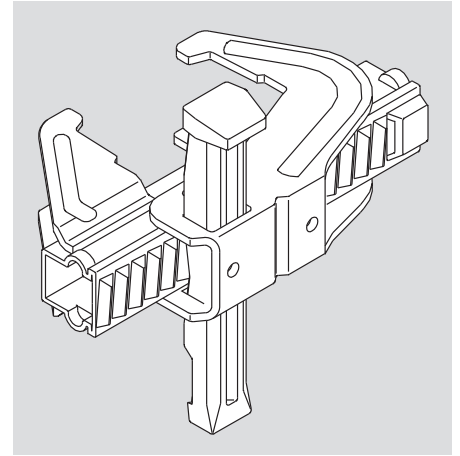

BFD Alignment Coupler
Item no. 023500 for connecting the panels.

Number of required couplers per panel joint

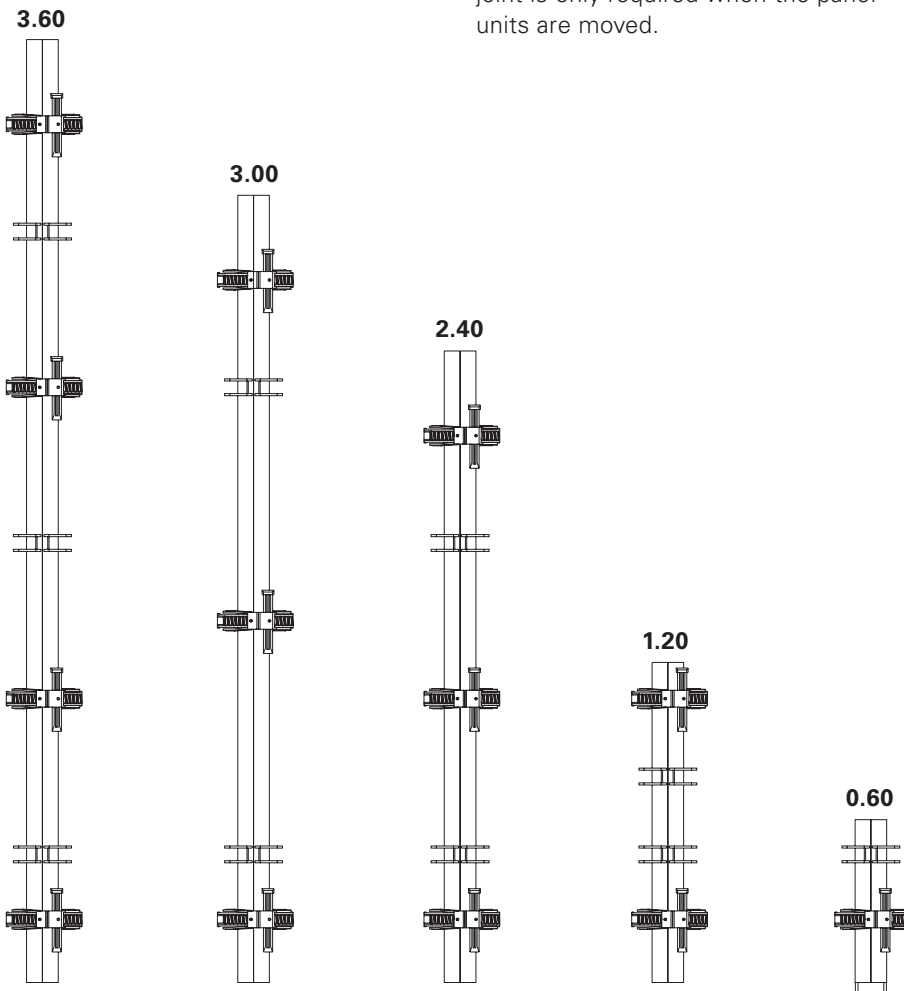

Note:
The Adjusting Spindle 500 on the panel joint is only required when the panel units are moved.

Note:
For extending the 120 elements, one BFD Alignment Coupler is sufficient.

RUNDFLEX

Compensation Timbers

Panels A 250 outside / I 240 inside

Inside Radius [m]	Wall Thickness d [m]				
	0.20	0.25	0.30	0.35	0.40
4.00	33	63	93		
4.20	27	55	84		
4.40	21	48	76		
4.60	16	42	68	94	
4.80	11	36	61	86	
5.00	6	30	54	78	
5.20	2	25	48	72	95
5.40	2	21	43	65	87
5.60	5	16	38	59	81
5.80	8	12	33	54	75
6.00	11	9	29	49	69
6.20	14	5	24	44	63
6.40	16	2	21	39	58
6.60	19	1	17	35	53
6.80	21	4	13	31	49
7.00	23	7	10	27	45
7.20	25	9	7	24	41
7.40	27	12	4	20	37
7.60	29	14	2	17	33
7.80	31	16	1	14	30
8.00	33	18	3	11	26
8.20	34	20	6	9	23
8.40	36	22	8	6	20
8.60	37	24	10	4	18
8.80	39	25	12	1	15
9.00	40	27	14	1	12
9.20	41	28	16	3	10
9.40	43	30	17	5	8
9.60	44	31	19	7	5
9.80	45	33	21	9	3
10.00	46	34	22	10	1
10.50	48	37	26	15	4
11.00	51	40	29	18	8

Inside Radius [m]	Wall Thickness d [m]				
	0.20	0.25	0.30	0.35	0.40
11.50	53	42	32	22	12
12.00	55	45	35	25	15
12.50	57	47	37	28	18
13.00	58	49	40	31	22
13.50	60	51	42	33	24
14.00	61	52	44	35	27
14.50	62	54	46	38	29
15.00	64	56	48	40	32
15.50	65	57	49	42	34
16.00	66	58	51	43	36
16.50	67	60	52	45	38
17.00	68	61	54	47	40
17.50	69	62	55	48	41
18.00	70	63	56	49	43
18.50	70	64	57	51	44
19.00	71	65	58	52	46
19.50	72	66	59	53	47
20.00	73	67	60	54	48

BA = Compensation timber width outside [mm]

BI = Compensation timber width inside [mm]

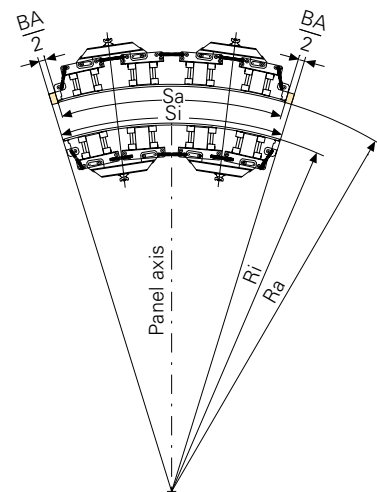

for $\frac{Ra}{Ri} = \frac{Sa}{Si}$ is
no compensation required

$\frac{Ra}{Ri} > \frac{Sa}{Si}$

yes

no

$BA = \frac{Ra}{Ri} Si - Sa$

$BI = \frac{Ra}{Ri} Sa - Si$

Compensation Timbers

Panels A 128 outside / I 123 inside

Inside Radius [m]	Wall Thickness d [m]				
	0.20	0.25	0.30	0.35	0.40
2.50	60	85			
2.60	56	79			
2.70	52	75	98		
2.80	48	70	92		
2.90	45	66	88		
3.00	42	62	83		
3.20	36	55	75	94	
3.40	31	49	68	86	
3.60	27	44	61	78	95
3.80	23	39	55	72	88
4.00	19	35	50	66	81
4.20	16	31	45	60	75
4.40	13	27	41	55	69
4.60	11	24	37	51	64
4.80	8	21	34	47	59
5.00	6	18	30	43	55
5.20	4	16	27	39	51
5.40	2	13	25	36	48
5.60	0	11	22	33	44
5.80	2	9	20	30	41
6.00	3	7	17	28	38
6.20	4	5	15	25	35
6.40	6	4	13	23	33
6.60	7	2	11	21	30
6.80	8	1	10	19	28
7.00	9	1	8	17	26
7.20	10	2	6	15	24
7.40	11	3	5	13	22
7.60	12	4	4	12	20
7.80	13	5	2	10	18
8.00	14	6	1	9	16
8.20	15	7	0	7	15
8.40	16	8	1	6	13

Inside Radius [m]	Wall Thickness d [m]				
	0.20	0.25	0.30	0.35	0.40
8.60	16	9	2	5	12
8.80	17	10	3	4	11
9.00	18	11	4	2	9
9.20	18	12	5	1	8
9.40	19	12	6	0	7
9.60	20	13	7	1	6
9.80	20	14	8	2	5
10.00	21	15	9	3	4
10.50	22	16	10	5	1
11.00	23	18	12	7	1
11.50	24	19	14	8	3
12.00	25	20	15	10	5
12.50	26	21	16	11	7
13.00	27	22	17	13	8
13.50	28	23	19	14	10
14.00	28	24	20	15	11
14.50	29	25	21	16	12
15.00	30	26	21	17	13
15.50	30	26	22	18	14
16.00	31	27	23	19	15
16.50	31	28	24	20	16
17.00	32	28	24	21	17
17.50	32	29	25	22	18
18.00	33	29	26	22	19
18.50	33	30	26	23	20
19.00	33	30	27	24	20
19.50	34	31	27	24	21
20.00	34	31	28	25	22

BA = Compensation timber width outside [mm]

BI = Compensation timber width inside [mm]

RUNDFLEX

Compensation Timbers

Panels A 85 outside / I 72 inside

Inside Radius Ri [m]		Wall Thickness d [m]					
		0.20	0.25	0.30	0.35	0.40	
1.00	BAi	Adjustable Spindle 210 inside	21	57	93		
	BAa			63	102		
1.10	BAi		7	40	73		
	BAa			44	79		
1.20	Bli		4	26	56	86	
	Bla				60	93	
1.30	Bli		12	14	42	69	97
	Bla				45	74	104
1.40	Bli		19	4	29	55	81
	Bla					59	86
1.50	Bli	26	5	19	43	67	
	Bla					71	
1.60	Bli	32	11	9	32	54	
	Bla					58	
1.70	Bli	37	17	1	22	44	
	Bla						
1.80	Bli	41	23	5	14	34	
	Bla						
1.90	Bli	46	28	11	6	25	
	Bla						
2.00	Bli	50	32	16	0	18	
	Bla						
2.10	Bli	53	37	21	6	11	
	Bla	50					
2.20	Bli	56	40	25	11	4	
	Bla	53					
2.30	Bli	59	44	29	15	1	
	Bla	56					
2.40	Bli	62	47	33	19	6	
	Bla	59					
2.50	Bli	64	50	36	23	10	
	Bla	61					
2.60	Bli	67	53	40	27	14	
	Bla	64					
2.70	Bli	69	56	43	30	18	
	Bla	66					
2.80	Bli	71	58	45	33	22	
	Bla	68					
2.90	Bli	73	60	48	36	25	
	Bla	70					
3.00	Bli	75	62	51	39	28	
	Bla						
3.10	Bli	76	64	53	42	31	
	Bla						
3.20	Bli	78	66	55	44	34	
	Bla						

Inside Radius Ri [m]		Wall Thickness d [m]					
		0.20	0.25	0.30	0.35	0.40	
3.30	BAi	Adjustable Spindle 500 inside	79	68	57	47	36
	BAa						
3.40	BAi		81	70	59	49	39
	BAa						
3.50	Bli		82	71	61	51	41
	Bla						
3.60	Bli		83	73	63	53	43
	Bla						
3.70	Bli		85	74	64	55	45
	Bla						
3.80	Bli	86	76	66	57	47	
	Bla						
3.90	Bli	87	77	68	58	49	
	Bla						
4.00	Bli	88	78	69	60	51	
	Bla						
4.10	Bli	89	80	70	62	53	
	Bla						
4.20	Bli	90	81	72	63	55	
	Bla						
4.30	Bli	91	82	73	65	56	
	Bla						
4.40	Bli	92	83	74	66	58	
	Bla						
4.50	Bli	92	84	75	67	59	
	Bla						

 BA = Compensation timber width outside [mm]

 BI = Compensation timber width inside [mm]

¹ If the width of the compensation timber varies more than 3 mm between inside and outside, the cut is rectangular.

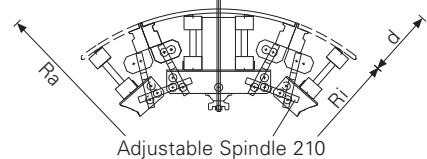
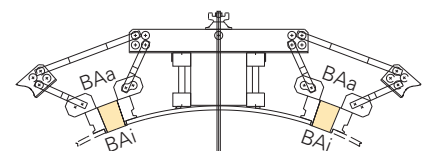

 BA = ¹ Compensation timber width on the outside panel [mm]

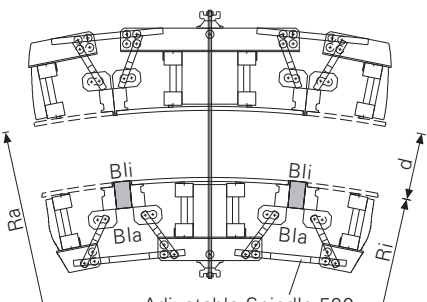

 BI = ¹ Compensation timber width on the inside panel [mm]

Safety instructions

When using RUNDFLEX circular formwork, the following points in particular must be taken into account:

When handling the elements, all valid safety regulations must be observed in every case.

Push-Pull Props and Kicker Braces are to be arranged as shown in the following drawing and table. When erecting, two push-pull props must always be attached to the first panel. Subsequent push-pull props according to the table. The Girder Headpiece 24 is used for connecting props to the RUNDFLEX panels, whilst fixing to the ground is carried out with Base Plates and Multi-Monti MMS 20 x 130 Anchor Bolts.

Planking and handrails for concreting scaffold are to be installed according to DIN 4420. Maximum spacing of Scaffold Bracket GB 80 = 1.25 m with a working load of 150 kg/m². Lateral guardrails are assembled using PERI End Handrail Frames 55 (Item no. 065066). Assembly of the concreting scaffold is carried out on horizontally positioned elements.

The maximum load-bearing capacity of the Crane Splice 24 is 700 kg with a maximum 15° crane sling angle.

Follow the instructions of use for the Crane Splice 24 closely!

Permissible fresh concrete pressure for PERI RUNDFLEX elements is 60 kN/m². When using external vibrators, utilisation guidelines of the respective manufacturer must be observed at all times.

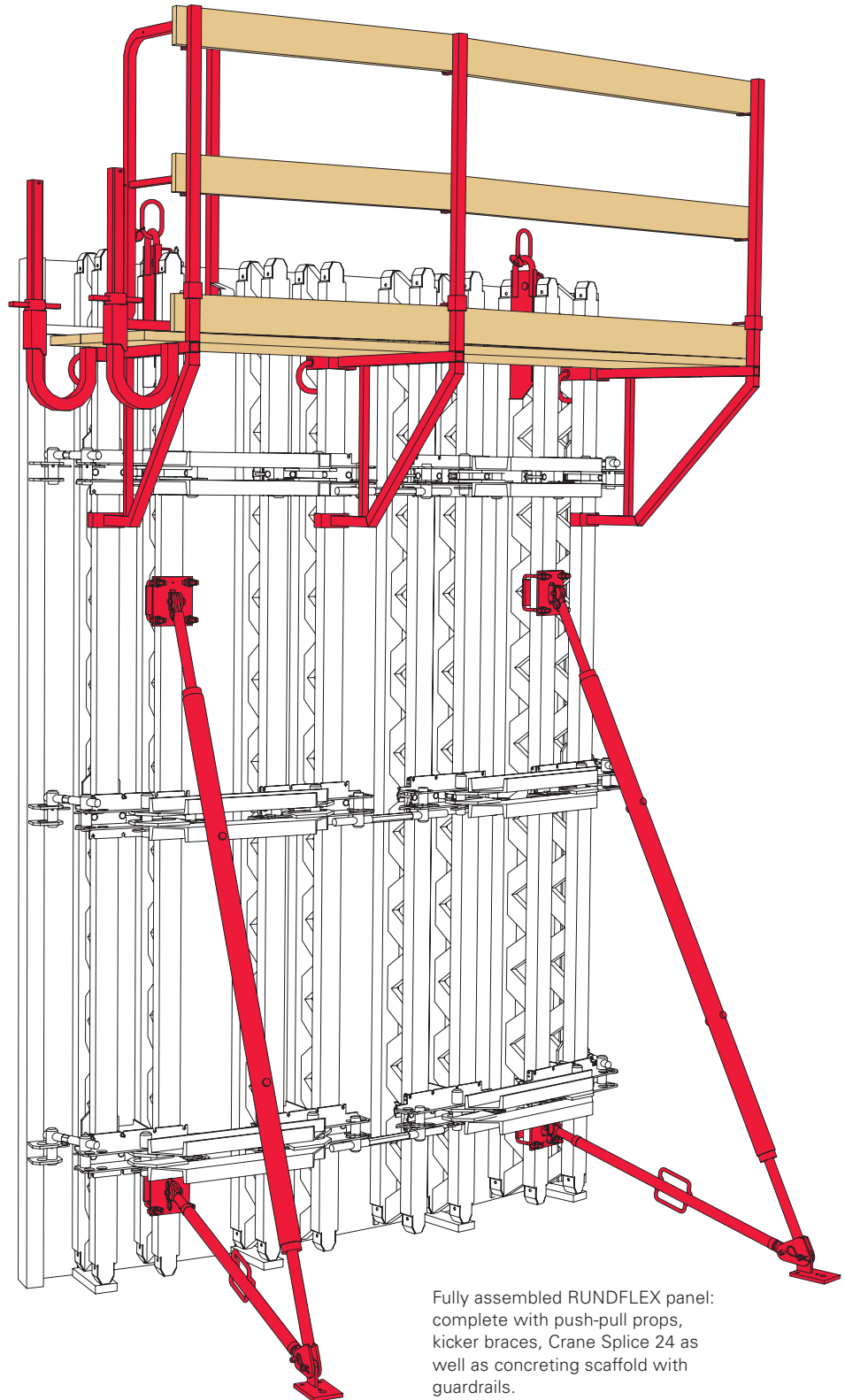

Fully assembled RUNDFLEX panel: complete with push-pull props, kicker braces, Crane Splice 24 as well as concreting scaffold with guardrails.

Item no.	Weight kg
021800	131,000
021820	181,000
102856	241,000
021840	339,000
021400	432,000
021880	533,000

- Outside Panels A 250**
- Outside Panel A 250 x 60**
- Outside Panel A 250 x 120**
- Outside Panel A 250 x 120 2R**
- Outside Panel A 250 x 240**
- Outside Panel A 250 x 300**
- Outside Panel A 250 x 360**

Ready-to-use formwork unit for circular structures.

Note

Panel without Distribution Waler. Panel A 250 x 60 complete with Crane Eye left and Crane Eye right.

Technical Data

Minimum radius 4.0 m. Plywood: 21 mm.
Permissible fresh concrete pressure 60 kN/m².

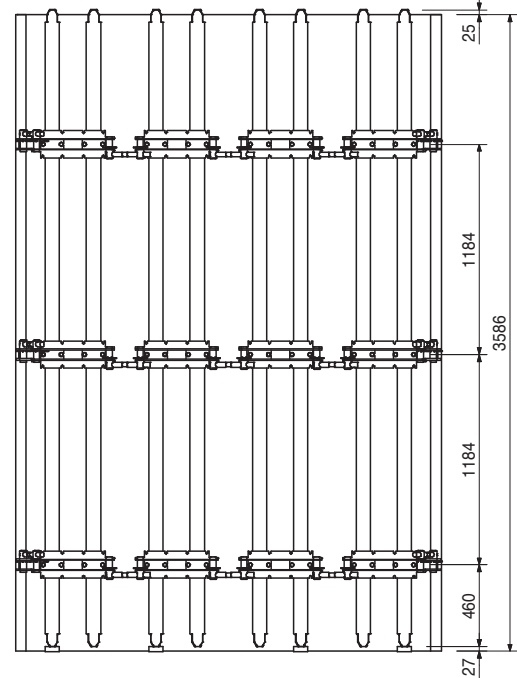
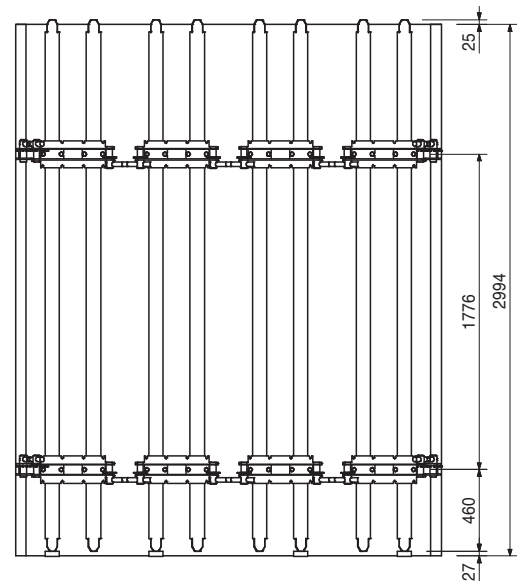
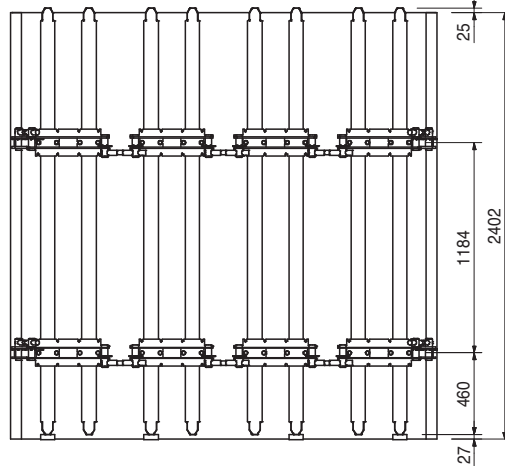
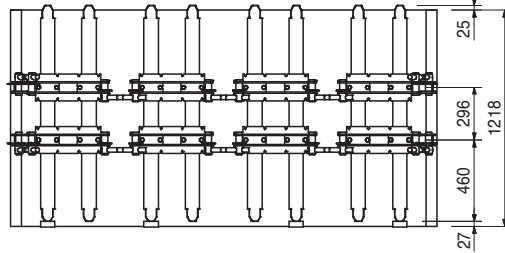
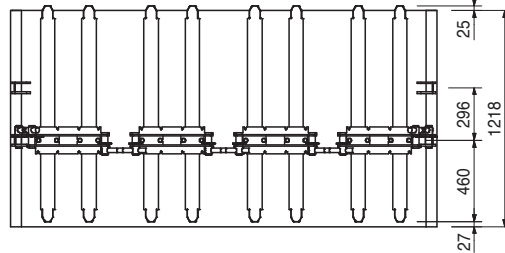
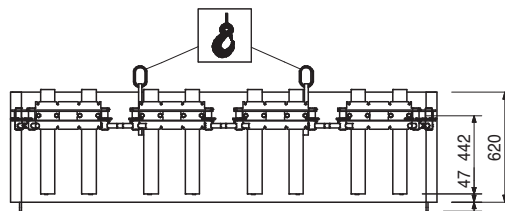
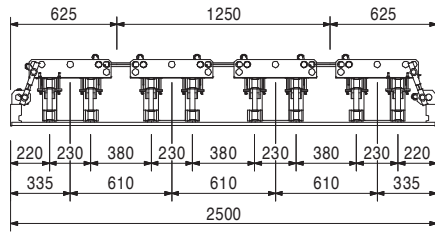

Item no.	Weight kg
021810	127,000
021830	173,000
102855	227,000
021850	343,000
021410	416,000
021890	510,000

- Inside Panels I 240**
- Inside Panel I 240 x 60**
- Inside Panel I 240 x 120**
- Inside Panel I 240 x 120 2R**
- Inside Panel I 240 x 240**
- Inside Panel I 240 x 300**
- Inside Panel I 240 x 360**

Ready-to-use formwork unit for circular structures.

Note

Panel without Distribution Waler. Panel I 240 x 60 complete with Crane Eye left and Crane Eye right.

Technical Data

Minimum radius 4.0 m. Plywood: 21 mm.
Permissible fresh concrete pressure 60 kN/m².

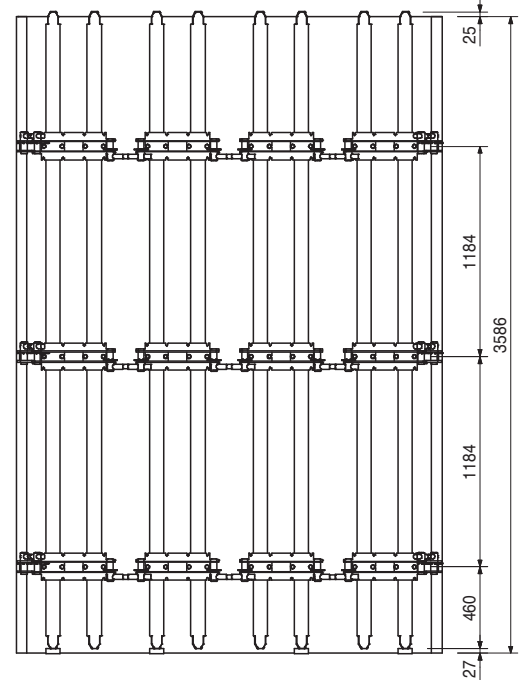
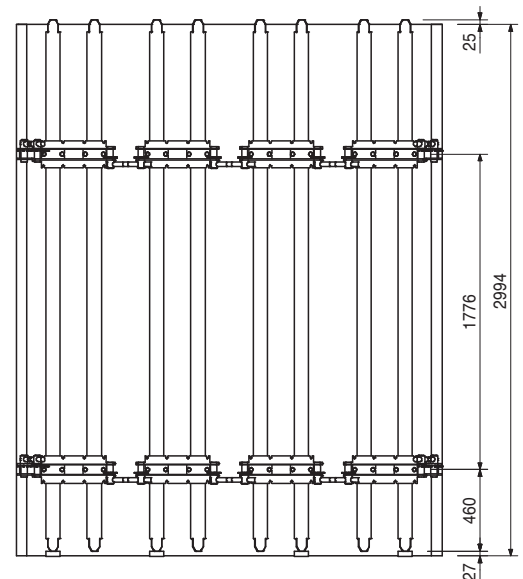
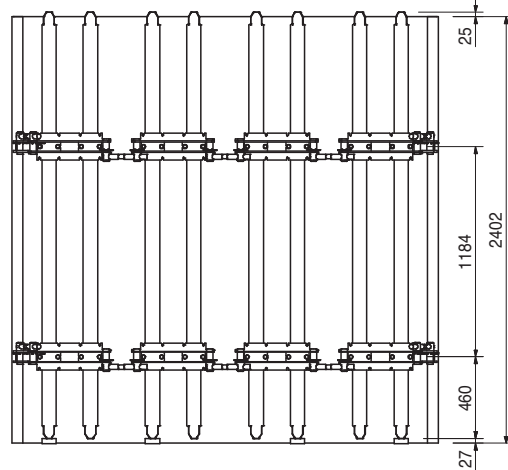
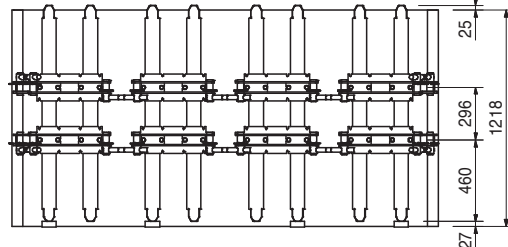
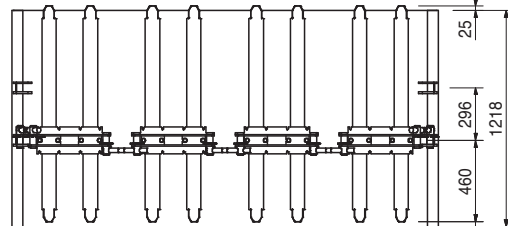
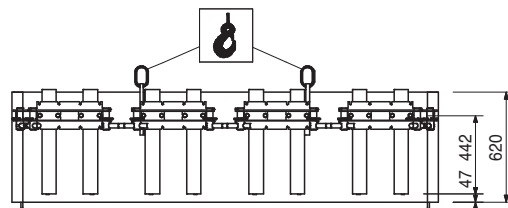
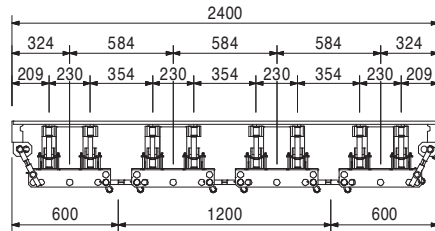

Item no.	Weight kg
021900	74,500
021920	102,000
102854	134,000
021940	200,000
021420	248,000
021960	298,000

- Outside Panels A 128**
- Outside Panel A 128 x 60**
- Outside Panel A 128 x 120**
- Outside Panel A 128 x 120 2R**
- Outside Panel A 128 x 240**
- Outside Panel A 128 x 300**
- Outside Panel A 128 x 360**

Ready-to-use formwork unit for circular structures.

Note

Panel without Distribution Waler. Panel A 128 x 60 complete with Crane Eye left and Crane Eye right.

Technical Data

Minimum radius 2.0 m. Plywood: 18 mm.
Permissible fresh concrete pressure 60 kN/m².

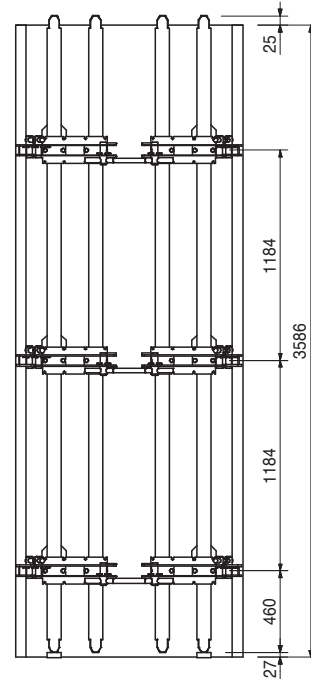
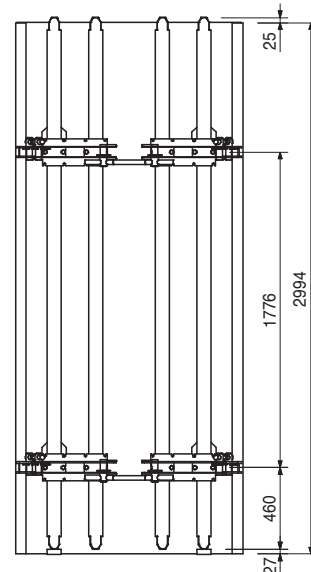
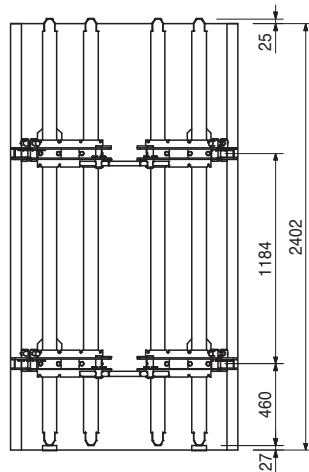
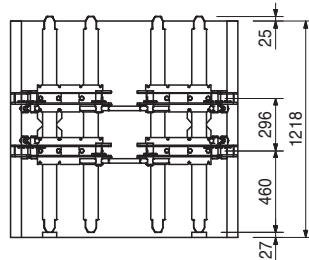
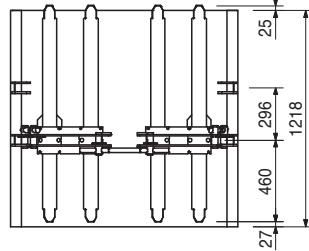
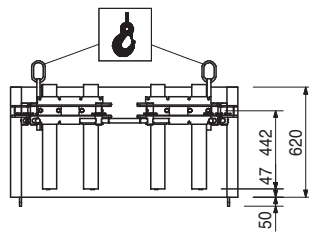
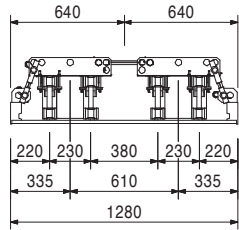

Item no.	Weight kg
021910	73,100
021930	97,100
102853	126,000
021950	190,000
021430	239,000
021970	283,000

- Inside Panels I 123**
- Inside Panel I 123 x 60**
- Inside Panel I 123 x 120**
- Inside Panel I 123 x 120 2R**
- Inside Panel I 123 x 240**
- Inside Panel I 123 x 300**
- Inside Panel I 123 x 360**

Ready-to-use formwork unit for circular structures.

Note

Panel without Distribution Waler. Panel I 123 x 60 complete with Crane eye left and Crane eye right.

Technical Data

Minimum radius 2.0 m. Plywood: 18 mm.
Permissible fresh concrete pressure 60 kN/m².

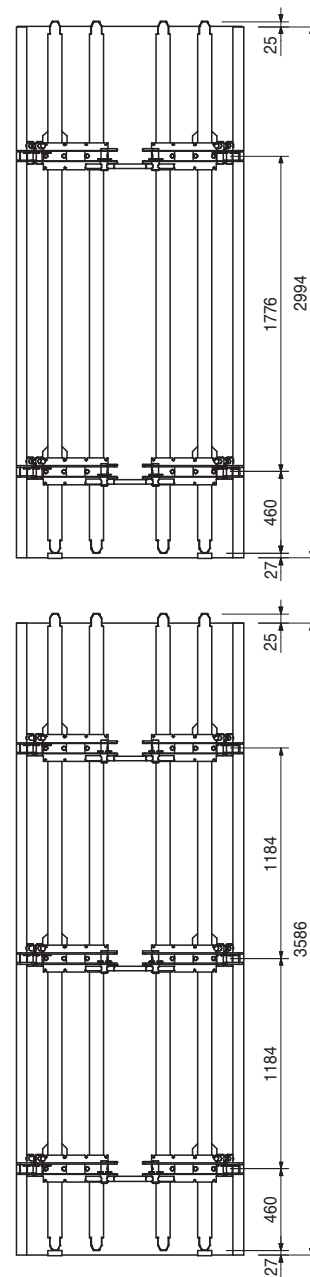
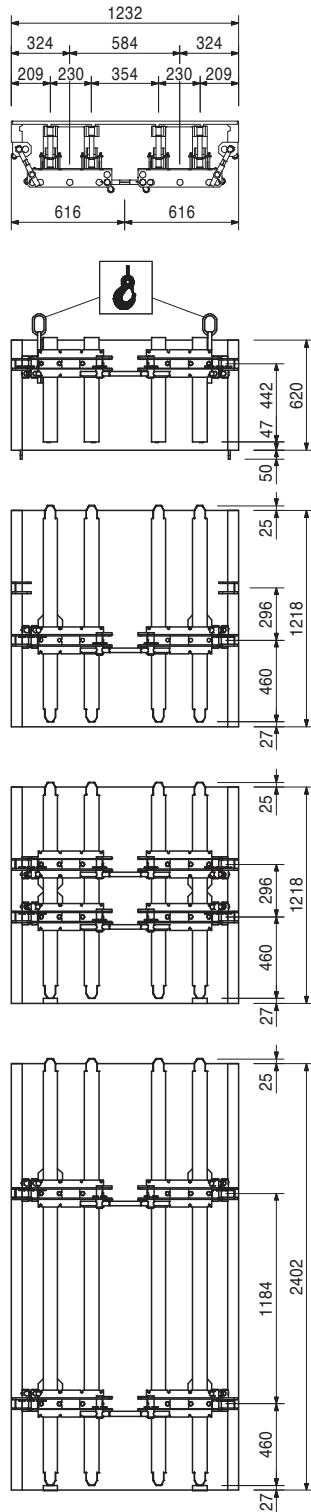

Item no.	Weight kg
020820	96,300
020840	142,000
020860	180,000
020880	211,000
020830	76,000
020850	118,000
020870	155,000
020890	176,000

Outside Panels A 85, Inside Panels I 72
Outside Panel A 85 x 120
Outside Panel A 85 x 240
Outside Panel A 85 x 300
Outside Panel A 85 x 360
Inside Panel I 72 x 120
Inside Panel I 72 x 240
Inside Panel I 72 x 300
Inside Panel I 72 x 360

Technical Data

Minimum radius 1.0 m. Plywood: 2 x 9 mm.
 Permissible fresh concrete pressure 60 kN/m².

Ready-to-use formwork unit for circular structures.

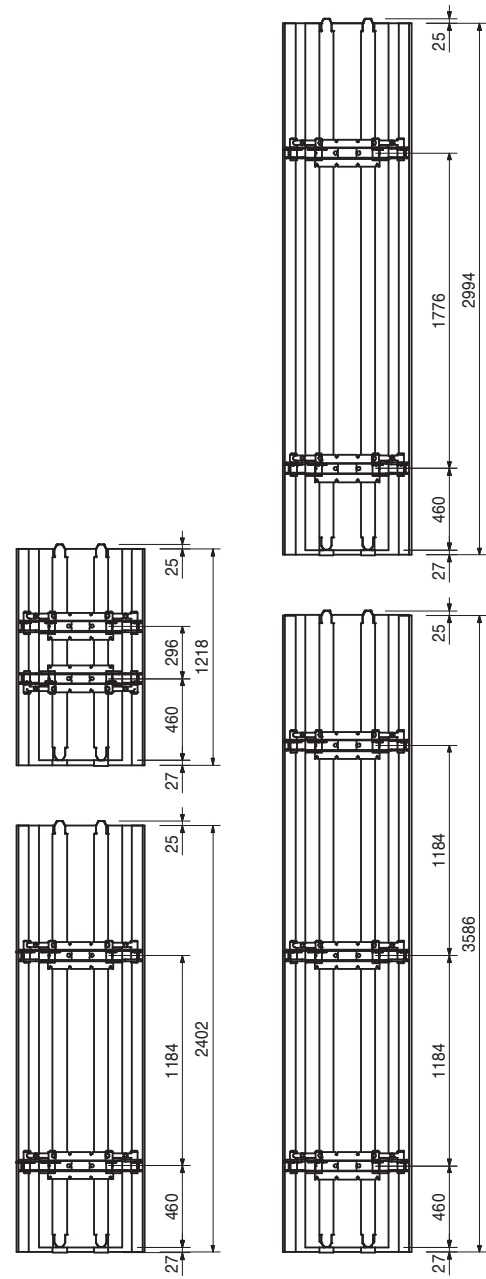
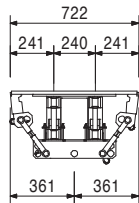
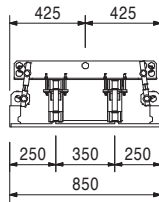

Item no.	Weight kg
023500	4,350

Alignment Coupler BFD, galv.

For all panel connections of MAXIMO, TRIO and RUNDFLEX. Compensations up to 10 cm.

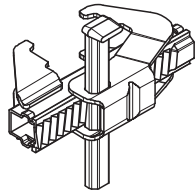

Technical Data

Permissible tension force 20.0 kN.

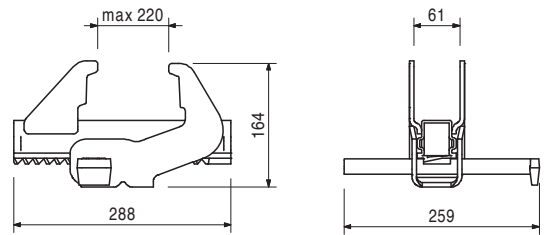

023940	6,080
--------	-------

Alignment Coupler 38, galv.

For connecting RUNDFLEX panels.

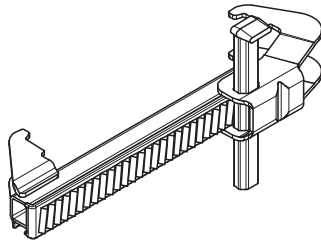

Note

Compensations up to 26 cm.

Technical Data

Permissible tension force 20.0 kN.

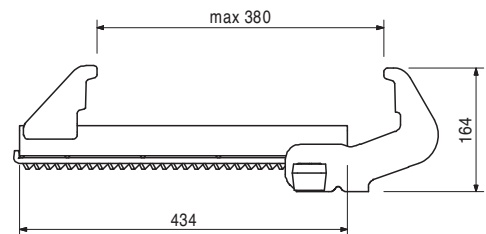

021620	3,770
--------	-------

Adjustable Spindle 500, galv.

For adjustment of RUNDFLEX outside panels. For outside and inside panel joints.

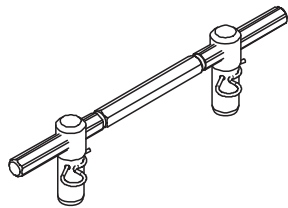

Complete with

2 x 022230 Cotter Pin 5/1, galv.

Note

With self-cleaning hexagonal thread. Spanner size SW 24

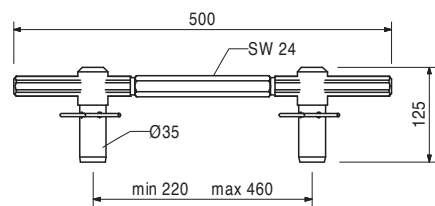

021610	2,830
--------	-------

Adjustable Spindle 210, galv.

For adjustment of RUNDFLEX inside panels and edge profiles on outside and inside panels.

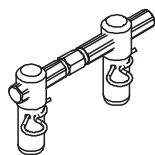

Complete with

2 x 022230 Cotter Pin 5/1, galv.

Note

With self-cleaning hexagonal thread. Spanner size SW 24.

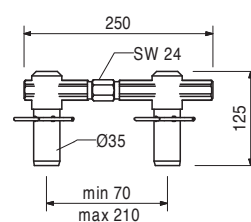

Item no.	Weight kg
021630	18,400

Distribution Waler

For transferring tie forces to adjacently-positioned T-walers.

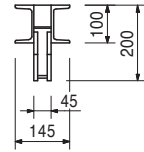
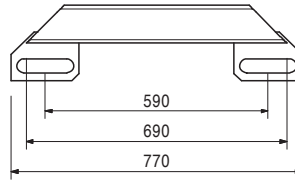
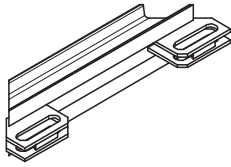

021640	1,260
--------	-------

Accessories

Waler Bolt, RUNDFLEX, galv. (x2)

021640	1,260
--------	-------

Waler Bolt, RUNDFLEX, galv.

For fixing Distribution Waler to T-waler.

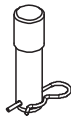

Complete with

1 x 022230 Cotter Pin 5/1, galv.

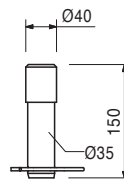

024480	7,040
--------	-------

Extension Splice 24-2

For height extension of GT 24 girders and VARIO GT 24 panels up to a max. height of 8.00 m.



Complete with

2 x 030190 Triple Wingnut DW 15, galv.

Note

Permissible load: see PERI Design Tables.

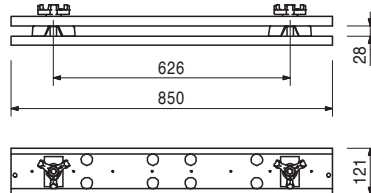

070760	4,650
--------	-------

Crane Splice 24

For transporting panels with GT 24 girders by crane.

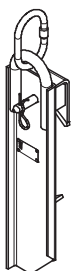

Complete with

1 x 018050 Pin Ø 16 x 65/86, galv.

1 x 018060 Cotter Pin 4/1, galv.

Note

Always use 2 pieces per transportation unit.

Safety instructions

Follow Instructions for Use! Load bearing capacity 0.7 t with a crane sling angle of ≤ 15°.

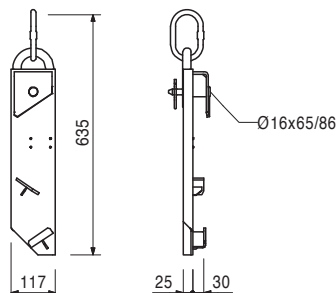

Item no.	Weight kg
021990	2,780
021980	2,780

Crane Eyes 24
Crane Eye 24, right
Crane Eye 24, left

For transporting panels with GT 24 girders by crane. Mounted on the panel.

Complete with

4 x 710138 Bolt ISO 4014 M10 x 110-8.8, galv.
 4 x 780356 Nut ISO 7042 M10-8, galv.
 4 x 710139 Washer R11 - DIN 440, galv.

Note

Illustration shows Crane Eye 24, left. Always use 2 pieces per transportation unit.

Safety instructions

Load-bearing capacity: 0.7 t with a crane sling angle of $\leq 15^\circ$.

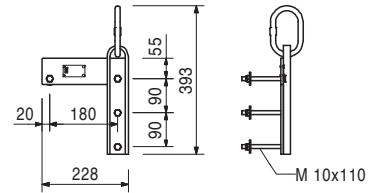
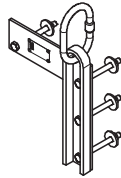

027110	10,800
--------	--------

Scaffold Bracket GB 80

For assembly of a working and concreting scaffold with VARIO GT 24.

Technical Data

Permissible load 150 kg/m² with a maximum width of influence of 1.25 m.

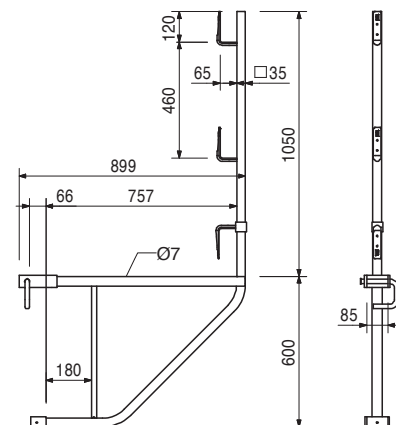
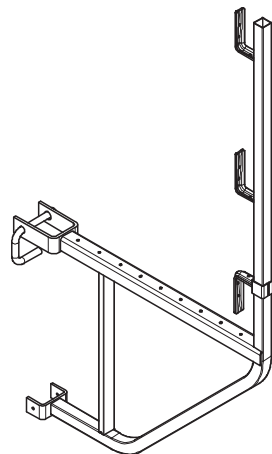

021790	1,000
--------	-------

Ratchet Spanner SW 24 "Combi"

For adjusting RUNDFLEX Panels and GKB Cantilevered Parapet Platforms.

Note

Spanner size SW 24. Length approx. 500 mm.

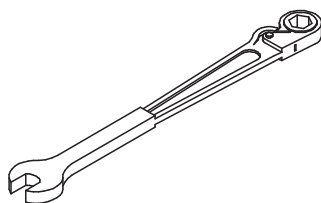

Item no.	Weight kg	RUNDFLEX Templates Template RF A250/I240, A128/I123 Template RF A85/172	Note Including material (plywood formlining). Produced according to project requirements.
099540	,000	The Template can be used for outside and inside panels.	
098217	,000		





01 PERI GmbH
 Rudolf-Diesel-Strasse
 89264 Weissenhorn
 info@peri.com
 www.peri.com



02 France
 PERI S.A.S.
 77109 Meaux Cedex
 peri.sas@peri.fr
 www.peri.fr

03 Switzerland
 PERI AG
 8472 Ohringen
 info@peri.ch
 www.peri.ch

04 Spain
 PERI S.A. Sociedad
 Unipersonal
 28110 Algete/Madrid
 info@peri.es
 www.peri.es

05 Belgium/Luxembourg
 N.V. PERI S.A.
 1840 Londerzeel
 info@peri.be
 www.peri.be

06 Netherlands
 PERI B.V.
 5480 AH-Schijndel
 info@peri.nl
 www.peri.nl

07 USA
 PERI Formwork Systems, Inc.
 Elkridge, MD 21075
 info@peri-usa.com
 www.peri-usa.com

08 Indonesia
 PT Beton Perkasa Wijaksana
 Jakarta 10210
 bpw@betonperkasa.com
 www.peri.de

09 Italy
 PERI S.p.A.
 20060 Basiano (MI)
 info@peri.it
 www.peri.it

10 Japan
 PERI Japan K.K.
 Tokyo 103-0015
 info@perijapan.jp
 www.perijapan.jp

11 United Kingdom/Ireland
 PERI Ltd.
 Rugby, CV23 0AN
 info@peri.ltd.uk
 www.peri.ltd.uk

12 Turkey
 PERI Kalıp ve İskeleleri
 Kırac - Büyükkemece/
 Istanbul 34500
 info@peri.com.tr
 www.peri.com.tr

13 Hungary
 PERI Kft..
 1181 Budapest
 info@peri.hu
 www.peri.hu

14 Malaysia
 PERI Formwork Malaysia
 43300 Seri Kembangan,
 Selangor DE
 info@perimalaysia.com
 www.perimalaysia.com

15 Singapore
 PERI ASIA Pte. Ltd
 Singapore 387355
 pha@periasia.com
 www.periasia.com

16 Austria
 PERI Ges.mbh
 3134 Nußdorf ob der Traisen
 office@peri.at
 www.peri.at

17 Czech Republic
 PERI spol. s r.o.
 252 42 Jesenice
 info@peri.cz
 www.peri.cz

18 Denmark
 PERI Danmark A/S
 2670 Greve
 peri@peri.dk
 www.peri.dk

19 Finland
 PERI Suomi Ltd. Oy
 05460 Hyvinkää
 info@perisuomi.fi
 www.perisuomi.fi

20 Norway
 PERI NORGE AS
 3036 Drammen
 info@peri.no
 www.peri.no

21 Poland
 PERI Polska Sp. z o.o.
 05-860 Płochocin
 info@peri.pl.pl
 www.peri.pl.pl

22 Sweden
 PERIform SVERIGE AB
 30013 Halmstad
 peri@periform.se
 www.periform.se

23 Korea
 PERI (Korea) Ltd.
 Seoul 135-080
 info@perikorea.com
 www.perikorea.com

24 Portugal
 PERIcofragens Lda.
 Linda-a-Pastora
 2790-326 Queijas
 info@peri.pt
 www.peri.pt

25 Argentina
 PERI S.A.
 (1625) Escobar/Prov. Bs. As.
 info@peri.com.ar
 www.peri.com.ar

26 Brazil
 PERI Formas e
 Escoramentos Ltda.
 CEP 06730-000
 Vargem Grande Paulista
 São Paulo
 info@peribrasil.com.br
 www.peribrasil.com.br

27 Chile
 PERI Chile Ltda.
 Colina, Santiago de Chile
 perich@peri.cl
 www.peri.cl

28 Romania
 PERI România SRL
 077015 Balotești - ILFOV
 info@peri.ro
 www.peri.ro

29 Slovenia
 PERI SLOWENIEN
 2000 Maribor
 peri.slo@triera.net
 www.peri.de

30 Slovakia
 PERI spol. s r.o.
 903 01 Senec
 info@peri.sk
 www.peri.sk

31 Australia
 PERI Australia Pty. Ltd.
 Glendenning NSW 2761
 info@periaus.com.au
 www.periaus.com.au

32 Estonia
 PERI AS
 76401 Saku vald
 Harjumaa
 peri@peri.ee
 www.peri.ee

33 Greece
 PERI Hellas Ltd.
 194 00 Koropi
 info@perihellas.gr
 www.perihellas.gr

34 Latvia
 PERI SIA
 1057 Riga
 info@peri-latvija.lv
 www.peri-latvija.lv

35 United Arab Emirates
 PERI (L.L.C.)
 Dubai
 perillc@perime.com
 www.perime.com



36 Canada
PERI Formwork Systems, Inc.
Bolton, Ontario
L7E 1K1
info@peri.ca
www.peri.ca

37 Libanon
PERI GmbH
Beirut
P.O. Box 90 416 Jdeidet
lebanon@peri.de
www.peri.de

38 Lithuania
PERI UAB
02300 Vilnius
info@peri.lt
www.peri.lt

39 Marocco
PERI S.A.
Tanger
peri25@menara.ma
www.peri.de

40 Israel
PERI Formwork
Engineering Ltd
49002 Israel
info@peri.co.il
www.peri.co.il

41 Bulgaria
PERI BULGARIA EOOD
1839 – Sofia
peri.bulgaria@peri.bg
www.peri.bg

42 Iceland
MEST Ltd.,
220 Hafnarfjordur
mest@mest.is
www.mest.is

43 Kazakhstan
TOO PERI Kazakhstan
050010 Almaty
peri@peri.kz
www.peri.kz

44 Russian Federation
OOO PERI
142403 Noginsk
moscow@peri.ru
www.peri.ru

45 South Africa
PERI Wiehahn (Pty.) Ltd.
Bellville 7535
ask@wiehahn.co.za
www.periwiehahn.co.za

46 Ukraine
TOW PERI Ukraina
02002 Kiev
peri@peri.ua
www.peri.ua

47 Egypt
PERI GmbH
11361 Heliopolis
Cairo
info@peri.com.eg
www.peri.com.eg

48 Serbia
PERI Oplate d.o.o.
11070 Novi Beograd
office@peri.co.yu
www.peri.co.yu

49 Mexico
PERI Cimbras y Andamios,
S.A. de C.V.
Estado de México,
C.P. 54680
info@peri.com.mx
www.peri.com.mx

50 Azerbaijan
PERI Kalip ve İskeleleri
Baku
peribaku@peri.com.tr
www.peri.com.tr

51 Turkmenistan
PERI Kalip ve İskeleleri
744035 Aşgabat
periashgabat@peri.com.tr
www.peri.com.tr

52 Belorussia
PERI Belarus
220030 Minsk
peri@mail.belpak.by
www.peri.com.tr

53 Croatia
PERI oplate i skele d.o.o.
10 250 Donji Stupnik/
Zagreb
info@peri.com.hr
www.peri.com.hr

54 Iran
PERI GmbH
Building No. 4
P.O. Box 1939793669
Teheran-Iran
iran@peri.ir
www.peri.ir

55 India
PERI (India) Pvt Ltd
Mumbai – 400064
info@peri.in
www.peri.in

56 Jordan
PERI Jordan
11947 Amman
jordan@peri.de
www.peri.de

57 Kuwait
PERI Kuwait
13011 Kuwait
kuwait@peri.de
www.peri.de

58 Saudi Arabia
PERI Saudi Arabia
Jeddah - 21463
K.S.A
saudi-arabia@peri.de
www.peri.de

59 Qatar
PERI Qatar LLC
Doha
qatar@peri.de
www.peri.de

60 Algeria
Société PERI S.A.S.
Kouba - Alger
peri.alger@peri.fr
www.peri.fr

61 Albania
Autostrada TIRANE-DURRES
Tirane / ALBANIA
info@peri.com.tr
www.peri.com.tr

62 Peru
PERI Peruana SAC
Lima/Peru
jeanpierre.saux@peri.com.pe
www.peri.com.pe

63 Panama
PERI Panama Inc.
587 Panama City
johnny.fernandezc@gmail.com
www.peri.com.pa

PERI Product Range



Wall Formwork

Panel Formwork
Girder Formwork
Circular Formwork
Facade Formwork
Brace Frame



Climbing Systems

Climbing Scaffold
Self-Climbing System
Climbing Protection Panel
Platform Systems



Column Formwork

Square
Rectangular
Circular



Scaffold, Stairways, Working Platforms

Facade Scaffold
Working Platform
Weather Protection Roof
Stairway Access



Slab Formwork

Panel Formwork
Beam Grid Formwork
Girder Formwork
Slab Table
Beam Formwork



Bridge and Tunnel Formwork

Cantilevered Parapet Carriage
Cantilevered Parapet Platform
Engineer's Construction Kit



Shoring Systems

Steel Slab Props
Aluminium Slab Props
Tower Systems
Heavy-Duty Props



Services

Formwork Assembly
Cleaning / Repairs
Formwork Planning
Software
Statics
Special Constructions

Additional Systems
Plywood
Formwork Girders
Stopend Systems
Pallets
Transportation Containers



PERI GmbH Formwork Scaffolding Engineering

P.O. Box 1264
89259 Weissenhorn
Germany
Tel +49 (0)73 09.9 50-0
Fax +49 (0)73 09.9 51-0
info@peri.com
www.peri.com