

# **VRB** Heavy-Duty Truss Girder

Instructions for Assembly and Use – Standard Configuration – Issue 10/2018

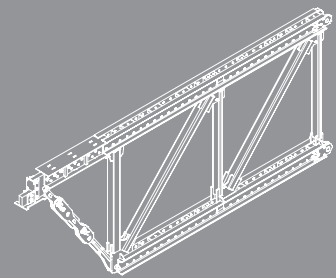

## Main Components

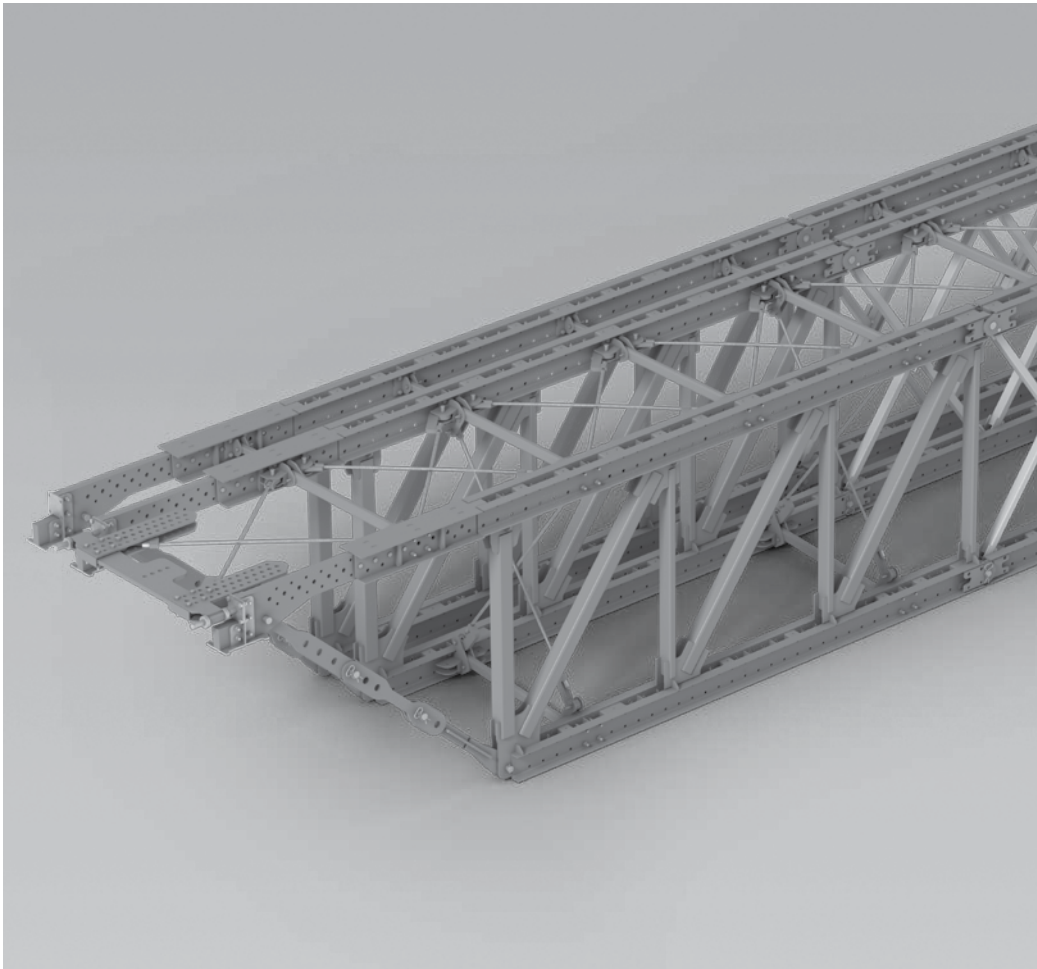
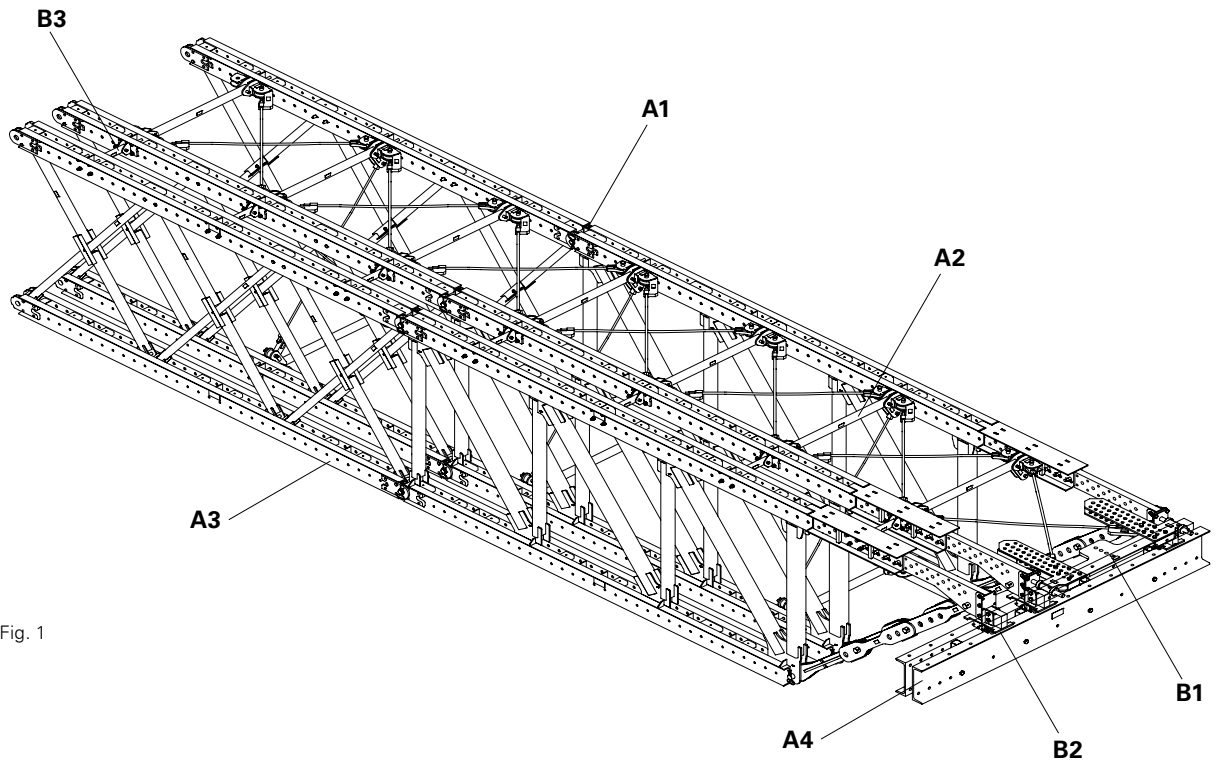

Fig. 1

- A1 Assembly of the Frame
- A2 Assembly of the Truss Package
- A3 Assembly of Single Trusses
- A4 Assembly of the Main Beam
- B1 Assembly of Truss Package on the Main Beam
- B2 Assembly of Single Girders on the Main Beam
- B3 Connecting Single Trusses to the Truss Package

## Overview

Main Components	3
Overall View of the Horizontal Bracing	4
Overall View of the Vertical Bracing	4
Overall View of the Single Truss	4
Overall View of the Truss Package	5
Key	6

## Introduction

Target Groups	7
Additional Technical Documentation	7
Intended Use	8
Instructions on Use	8
Cleaning and Maintenance Instructions	9

## Safety Instructions

Cross-System	10
System-Specific	11
Storage and Transportation	11
Assembly	11

## Component Overview and Tool List

Parts List	12
Tool List	13
Tightening Torque	13

## A Work Preparation

A1	Frame Assembly	14
	Assembly Preparation	14
	Load-Bearing Capacity	14
	Safety Instructions	14
	Mounting the Standard Frames	15
	Connecting the Standard Frames	17
	Connecting the Bearing Frames	19
	Adjusting the Bearing Frames	21
A2	Assembly of the Truss Package	24
	Mounting the Bracing Shoe	24
	Mounting the Bracing Posts	26
	Mounting the Second Frame	26
	Connecting Both Single Trusses	27
	Mounting the Bracing Traverse	28
	Mounting the Horizontal Bracing	29
	Mounting the Vertical Bracing	32
	Coupling with a Single Truss	34
A3	Assembly of Single Trusses	35
	Mounting the Coupling Shoes	35
A4	Assembly of the Main Beam	37
	Mounting the Horizontal Bearing	37
	Supporting with the Cross Fall Bearing	38
	Supporting without the Cross Fall Bearing	40
	Coupling the Main Beams	41

## B Application

B1	Assembly of Truss Package on the Main Beam	42
B2	Assembly of Single Trusses on the Main Beam	45
B3	Connecting Single Trusses to the Truss Package	46

## C Support Variations

C1	Support Situation for Longitudinal Inclinations	48
C2	Support Situation for Lateral Inclinations	49
C3	Support Situation for Crossing Angles	50
	Crossing Angle from 67.4° to 90°	50
	Crossing Angle from 63.4° to 67.4°	51

## D Scaffold Installation

D1	Installation of PERI UP Flex Connection Assembly	52
	Assembly in the Truss Package	53
	Assembly of Bracket Connection	55
	Assembly of Bracket on the Truss Package	56

## E Removal and Dismantling

E1	Dismantling the Heavy-Duty Truss Girder	58
E2	Dismantling	61
	Dismantling Single Trusses	61
	Dismantling the Truss Package	62

## Components

	VRB Heavy-Duty Truss Girder	64
--	-----------------------------	----

## Overall View of the Horizontal Bracing

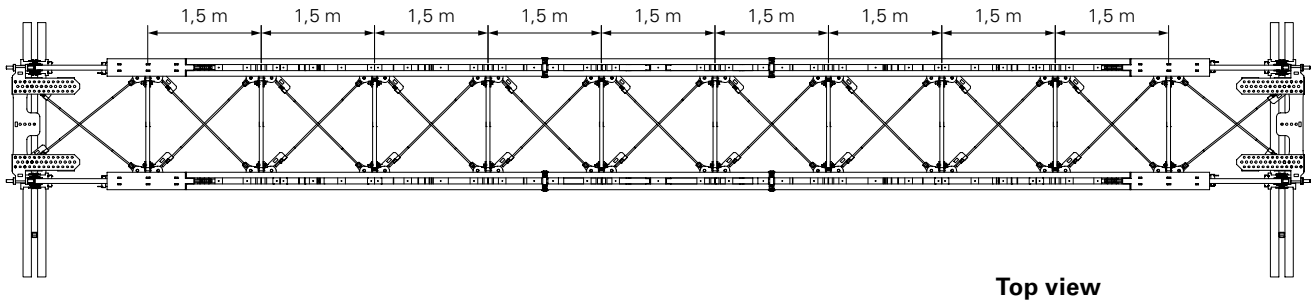

Fig. 2

## Overall View of the Vertical Bracing

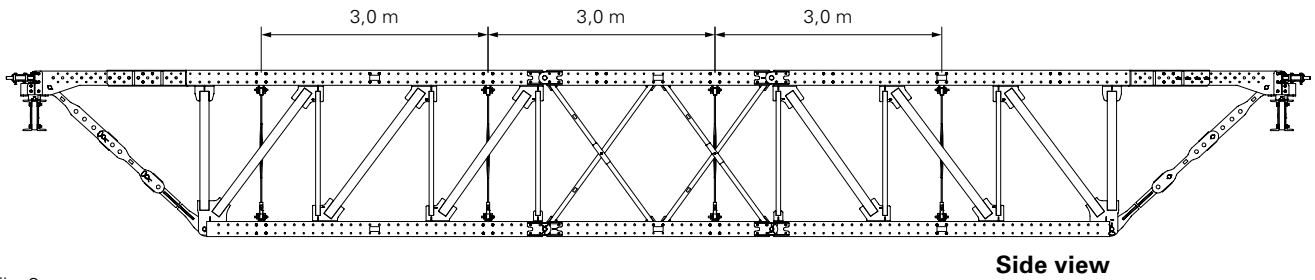

Fig. 3

## Overall View of the Single Truss

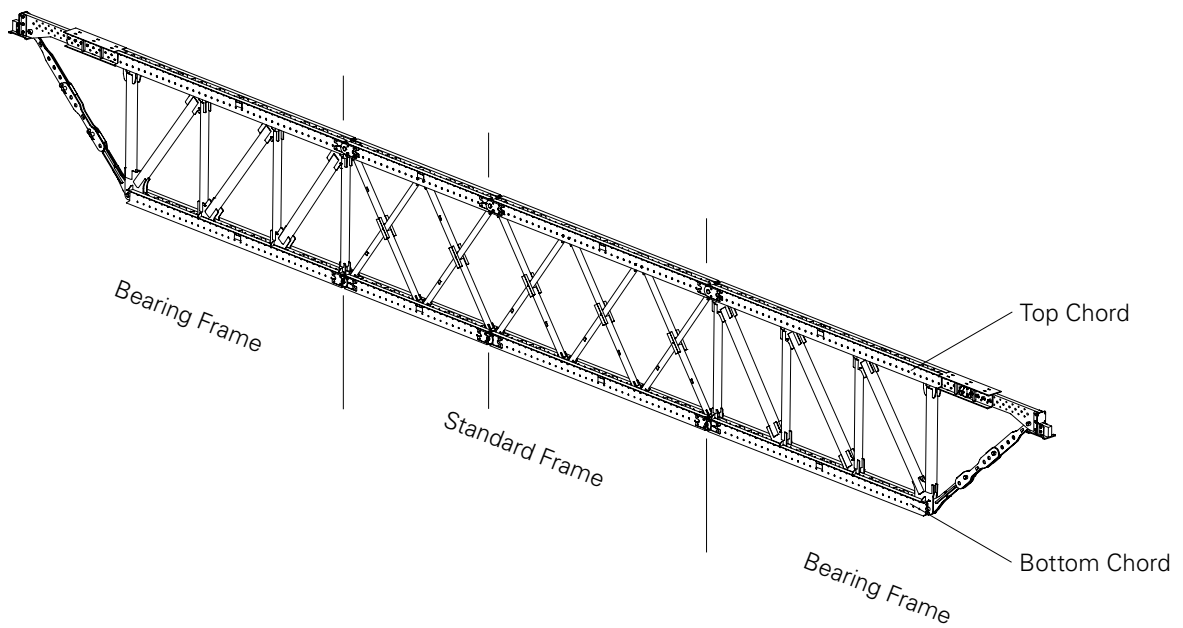

Fig. 4

## Overall View of the Truss Package

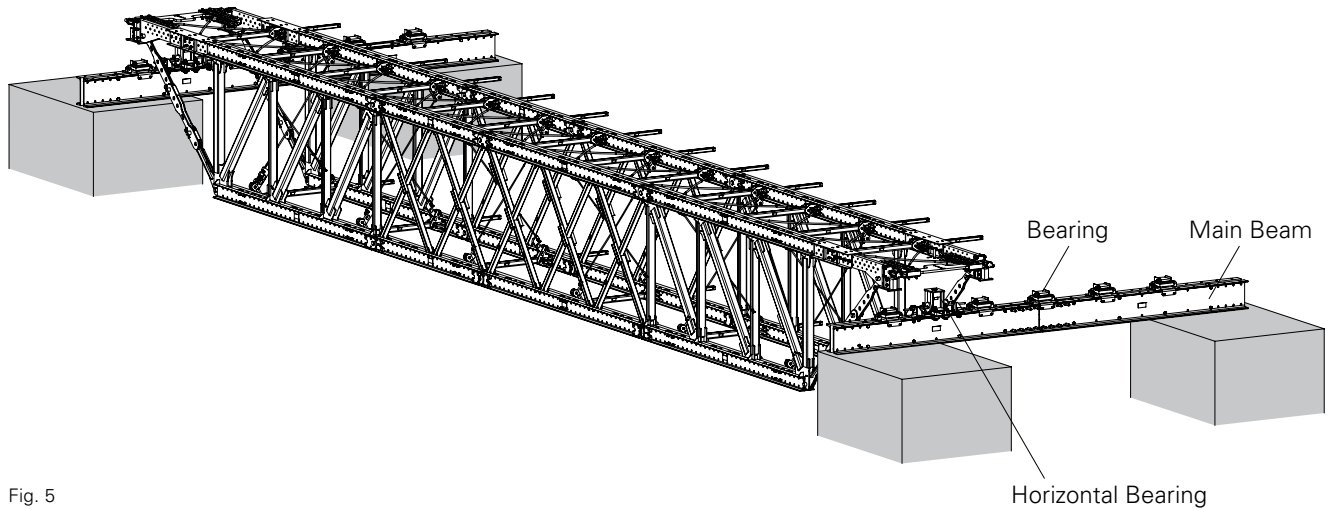

Fig. 5

The Horizontal Bearing accommodates the horizontal forces, e.g. wind loads, and transfers them to the Main Beam. The Bearing, which consists of a Cross Fall Bearing and Longitudinal Bearing, accommodates the vertical forces and transfers them to the Main Beam.

## Key

### Pictogram | Definition



Danger / warning / caution



Information



To be complied with



Load-bearing point



Visual check



Tip



Misapplication



Safety helmet



Safety shoes



Safety gloves



Safety glasses



Personal protective equipment to prevent falling from a height (PPE)

### Arrows



Arrow representing an action



Arrow representing a reaction of an action\*



Forces

\* if not identical to the action arrow.

### Safety instruction categories

The safety instructions alert site personnel to the risks involved and provide information on how to avoid these risks. Safety instructions are featured at the beginning of the section or ahead of the instructions, and are highlighted as follows:



#### Danger

This sign indicates an extremely hazardous situation which, if not avoided, will result in death or serious injury.



#### Warning

This sign indicates a hazardous situation which, if not avoided, could result in death or serious injury.



#### Caution

This sign indicates a hazardous situation which, if not avoided, could result in minor or moderate injury.



#### Information

This sign indicates situations in which failure to observe the information can result in material damage.

### Set-up of the safety instructions



#### Signal word

Type and source of the danger!  
Consequences of non-compliance.  
⇒ Avoidance measures.

### Dimension specifications

Dimensions are usually given in cm. Other measurement units, e.g. m, are shown in the illustrations. Load details are usually given in kg. Other measurement units, e.g. t, are specified in the illustrations.

### Conventions

- Instructions are numbered with: 1. ...., 2. ...., 3. ....
- The result of an instruction is shown by: →
- Position numbers are clearly provided for the individual components and are given in the drawing, e.g. **1**, in the text in brackets, for example (1).
- Multiple position numbers, i.e. alternative components, are represented with a slash: e.g. **1 / 2**.

### Presentational reference

The illustration on the front cover of these instructions is understood to be a system representation only. The assembly steps presented in these Instructions for Assembly and Use are shown in the form of examples with only one component size. They are valid accordingly for all component sizes contained in the standard configuration.

For a better understanding, detailed illustrations are partly incomplete. Some safety installations which have possibly not been shown in these detailed descriptions must nevertheless be available.

## Target Groups

### Contractors

These Instructions for Assembly and Use are designed for contractors who use the scaffolding either for

- assembling, modifying and dismantling purposes, or use
- it, e.g. for concreting, or who have it used, e.g. for forming operations.

### Construction site coordinator

The Safety and Health Protection Coordinator\*

- is appointed by the client,
- must identify potential hazards during the planning phase,
- determines measures that provide protection against risks,
- creates a health and safety plan,
- coordinates the protective measures for the contractor and site personnel so that they do not endanger each other,
- monitors compliance with the protective measures.

### Competent person

Due to the specialist knowledge gained from professional training, work experience and recent professional activity, the competent person qualified to carry out inspections has a reliable understanding of safety-related issues and can correctly carry out inspections. Depending on the complexity of the test to be undertaken, e.g. scope of testing, type of testing or the use of certain measuring devices, a range of specialist knowledge is necessary.

### Qualified personnel

PERI products may only be assembled, modified or dismantled by personnel who are suitably qualified to do so. For the work to be carried out, the qualified personnel must have received instruction\*\* covering at least the following points:

- Explanation of the plan for the assembly, modification or dismantling of the scaffolding in an understandable form and language.
- Description of the measures for safely assembling, modifying or dismantling the scaffolding.

- The preventive measures to be taken to avoid the risk of persons and objects falling.
- Designation of the safety precautions in the event of changing weather conditions which could adversely affect the safety of the PERI products concerned as well as the personnel.
- Details regarding permissible loads.
- Any other risks that are associated with the assembly, modification or dismantling procedures.



- **In other countries, ensure that the relevant national guidelines and regulations in the respective current version are complied with!**
- **If no country-specific regulations are available, it is recommended to proceed according to German guidelines and regulations.**
- **A competent person must be present on site during scaffolding operations.**

\* Valid in Germany: Regulations for Occupational Health and Safety on Construction Sites 30 (RAB 30)

\*\* Instructions are given by the contractor himself or a competent person selected by him.

---

## Additional Technical Documentation

Instructions for Assembly and Use:

- VST Heavy-Duty Shoring Tower

Instructions for Use:

- Hydraulic Head Spindle Device VST

- PERI UP Flex
- PERI Design Tables - Formwork and Shoring

## Intended Use

### Product description

PERI products have been designed for exclusive use in the industrial and commercial sectors by qualified personnel only.

The VRB Heavy-Duty Truss Girder is used for the temporary transfer of static loads from in-situ concrete or prefabricated elements in bridge construction.

Likewise, temporary spans in scaffolding or industrial constructions can be realised.

### Features

The VRB Heavy-Duty Truss Girder construction consists of Bearing Frames and Standard Frames which are mounted using connecting parts to form single trusses or truss packages, and then positioned on the Main Beam. See Fig. 1 - 5.

Two single trusses are coupled together to assemble a truss package and connected by means of Bracing Shoes and Bracing Posts. This package is braced using horizontal and vertical bracing. For connecting additional single trusses, corresponding Coupling Shoes are mounted.

The typical construction consists of a truss package whereby additional single trusses are coupled on the left and right respectively.

Continuous length adjustment is made possible by the telescopic Bearing Frame. Trusses are transported to the place of operation by crane completely assembled. Depending on the inclination, position the Cross Fall Bearing and Longitudinal Bearing between the Bearing Frames and Main Beams. The trusses are mounted on the Main Beams. Horizontal forces are transferred using the Horizontal Bearing. Crossing angles can be realised by means of the telescopic Bearing Frame along with the flexible Bracing Traverse. PERI UP Flex can be mounted on the truss with the corresponding connections to provide safe access technology.

### Technical data:

- Max. span 40 m
- Continuous length adjustment
- approx. 3,000 kNm perm. bending moment
- Max. longitudinal inclination: 7 %
- Max. lateral inclination: 7 %
- Crossing Angle: 63.4° – 90°

---

## Instructions on Use

Use in a way not intended according to the Instructions for Assembly and Use, or any use deviating from the standard configuration or the intended use, represents a misapplication with a potential safety risk, e.g. risk of falling.

Only PERI original parts may be used. The use of other products and spare parts is not allowed.

Changes to PERI components are not permitted.

## Cleaning and Maintenance Instructions

Clean the elements after each use to maintain the value and usability of the PERI products over the long term.

Some repair work may also be inevitable due to the tough working conditions.

The following points should help to keep cleaning and maintenance costs as low as possible.

Damaged components must be exchanged immediately on site and may no longer be used.

Provide suitable support for the components during cleaning so that no unintentional change in their position is possible.

Do not clean powder-coated or galvanised components with steel brushes or metal scrapers.

Mechanical components, e.g. spindles, must be cleaned of dirt or concrete residue before and after use, and then greased with a suitable lubricant.

Do not clean components suspended on crane lifting gear.

Any repairs to PERI products are to be carried out by PERI qualified personnel only.

Only PERI original components are used when replacing parts.

## Information regarding the use of the Longitudinal and Cross Fall Bearings

The bearing surfaces of the Longitudinal and Cross Fall Bearings are lubricated with long-life grease and require no special maintenance.

Avoid any soiling of the bearings. It is essential to remove external soiling before use. See "Bearing with the Cross Fall Bearing" on Page 38 and "Bearing without the Cross Fall Bearing" on Page 40.

## Cross-System

### General

The contractor must ensure that the Instructions for Assembly and Use supplied by PERI are available at all times and understood by the site personnel.

These Instructions for Assembly and Use can be used as the basis for creating a risk assessment. The risk assessment is compiled by the contractor. However, these Instructions for Assembly and Use do not replace the risk assessment!

Always take into consideration and comply with the safety instructions and permissible loads.

For the application and inspection of PERI products, the current safety regulations and guidelines valid in the respective countries must be observed.

Materials and working areas are to be inspected on a regular basis, especially before each use and assembly, for:

- signs of damage,
- stability and
- functionality.

Damaged components must be exchanged immediately on site and may no longer be used.

Safety components are to be removed only when they are no longer required.

Components provided by the contractor must conform to the characteristics required in these Instructions for Assembly and Use, as well as all valid construction guidelines and standards. Unless otherwise indicated, this applies in particular to:

- timber components: Strength Class C24 for Solid Wood according to EN 338.
- scaffold tubes: galvanised steel tubes with minimum dimensions of  $\varnothing 48.3 \times 3.2$  mm according to EN 12811-1:2003 4.2.1.2.
- scaffold tube couplings according to EN 74.

Deviations from the standard configuration are only permitted after a further risk assessment has been carried out

by the contractor.

Appropriate measures for working and operational safety, as well as stability, are defined on the basis of this risk assessment.

Corresponding proof of stability can be provided by PERI on request if the risk assessment and resulting measures to be implemented are made available.

Before and after exceptional occurrences that may have had an adverse effect regarding the safety of the Heavy-Duty Truss Girder, the contractor must immediately

- create an additional risk assessment, with appropriate measures for ensuring the stability of the formwork system being carried out based on the results,
- arrange for an extraordinary inspection to be carried out by competent person qualified to do so. The aim of this inspection is to identify and rectify any damage in good time, in order to guarantee the safe use of the Heavy-Duty Truss Girder.

Exceptional occurrences can include:

- accidents,
- longer periods of non-use,
- natural events, e.g. heavy rainfall, icing, heavy snowfall, storms or earthquakes.

### Assembly, modification and dismantling work

Assembly, modification or dismantling of Heavy-Duty Truss Girders may only be carried out by qualified persons and under the supervision of a competent person. The qualified persons must have received appropriate training for the work to be carried out with regard to specific risks and dangers.

On the basis of the risk assessment and the Instructions for Assembly and Use, the contractor must create installation instructions, in order to ensure safe assembly, modification and dismantling of Heavy-Duty Truss Girders.

Before initial use, the safe functioning of the Heavy-Duty Truss Girder must be checked by a person qualified to carry out the inspection. The results of

the inspection must be documented in an inspection record.

The contractor must ensure that the personal protective equipment required for the assembly, modification or dismantling of the shoring system, e.g.

- safety helmet,
- safety shoes,
- safety gloves,
- safety glasses,

is available and used as intended.

If personal protective equipment against falling (PPE) is required or specified in local regulations, the contractor must determine appropriate attachment points on the basis of the risk assessment.

The contractor stipulates the PPE to be used to prevent falling.

The contractor must

- provide safe working areas for site personnel which are to be reached through the provision of safe access ways. Areas of risk must be cordoned off and clearly marked.
- ensure stability during all stages of construction, in particular during assembly, modification and dismantling operations.
- ensure and prove that all loads can be safely transferred.

### Utilisation

Every contractor who uses or allows the scaffolding system or sections of the scaffolding system to be used, is responsible for ensuring that the equipment is in good condition.

If the scaffolding system is used successively or at the same time by several contractors, the health and safety coordinator must point out any possible mutual hazards, and all work must then be coordinated.

## System-Specific

For each time of use, a detailed project-specific static calculation and planning is required!

Both assembly and dismantling must be planned on a project-specific basis while taking into account all intermediate status and individual boundary conditions.

Load-distributing support used for the assembly, e.g. planking, must match the respective base. If several layers are required, planks are to be arranged crosswise.

Secure individual girders during assembly in order to prevent tipping.

Use PERI UP Flex to ensure safe and secure access to all working areas.

Lock the Decking Transom using the integrated protection against lifting. The securing hook must be flush with the deck.

Secure wedges using a 500-g hammer.

Secure fitting pins with cotter pins.

Secure bolts with self-locking nuts. Only use the self-locking nuts once.

When transporting by crane:

- Ensure that components are picked up and set down so that unintentional falling over, falling apart, sliding, falling down or rolling is avoided.
- No persons are allowed to remain under the suspended load.
- Leave the area of risk on the Main Beam.
- Remove or secure any loose components.
- Do not transport persons, building materials or tools when moving with the crane.

## Storage and Transportation

Store and transport components ensuring that no unintentional change in their position is possible. Detach lifting accessories and slings from the lowered components only if they are in a stable position and no unintentional change is possible.

Do not drop the components.

Use PERI lifting accessories and slings and only the lifting points provided on the component.

During the moving procedure

- ensure that components are picked up and set down so that unintentional falling over, falling apart, sliding, falling down or rolling is avoided.
- no persons are allowed to remain under the suspended load.

Always guide pre-assembled scaffolding bays, scaffolding units or scaffolding sections with ropes when moving them by crane.

The access areas on the construction site must be free of obstacles and tripping hazards, as well as being slip-resistant.

For transportation, the surface used must have sufficient load-bearing capacity.

Use original PERI storage and transport systems, e.g. crate pallets, pallets or stacking devices.

## Assembly

The contractor must ensure that the user has the appropriate and sufficient number of tools, lifting equipment and slings, suitable and sufficient space for assembly and storage, as well as adequate crane capacity at his disposal.

Assess the degree of risk in each individual case and, if necessary, take measures to prevent or at least minimise the risk.

If anti-fall protection cannot be used or has to be removed due to operational reasons, safety equipment must be installed in its place in order to prevent or arrest falls from any height.

If the use of fall arrest equipment is deemed to be inappropriate, personal protection equipment (PPE) can be used if suitable fixing points are available.

Site personnel are forbidden to remain in areas below where assembly work is being carried out unless the area of risk has been provided with sufficient protection against falling, overturned, sliding or rolling objects and masses.

Cordon off areas of risk.

# Component Overview and Tool List



Pos. no.	Component name	Item no.	Pos. no.	Component name	Item no.
1	<b>Standard Frames</b>			<b>Small components</b>	
1.1	Standard Frame 3.0 m VRB	127285	40	Cotter Pin 4/1	018060
1.2	Standard Frame 4.5 m VRB	125155	41	Cotter Pin 5/1	022230
1.3	Standard Frame 6.0 m VRB	125156	42	Cotter Pin 6/1 Ø 50 VRB	125356
2	<b>Bearing Frames</b>		43	Fitting Pin Ø 21 x 105 VRB	125349
2.1	Bearing Frame 5.25 m VRB	128086	44	Fitting Pin Ø 21 x 120	104031
2.2	Bearing Frame 6.0 m VRB	126578	45	Fitting Pin Ø 26 x 105 VRB	125345
	<b>Bracing components</b>		46	Fitting Pin Ø 26 x 105 VRB	111567
3	Bracing Shoe VRB	125764	47	Fitting Pin Ø 30 VRB	125347
4	Vertical Bracing Shoe VRB	125770	48	Bolt Ø 50 x 155	113626
5	Coupling Shoe VRB	125732	49	Bolt Ø 50 x 250	125355
6	Bracing Post		52	Bolt ISO 4014 M20 x 150-8.8	711084
6.1	Bracing Post 1.50 m VRB	125734	60	Hex. Nut DW 15 SW 30/50	030070
6.2	Bracing Post 2.25 m VRB	125736	61	Hex. Nut DW 20 SW 36/60	030580
7	Coupling Posts		62	Nut ISO 7040 M20-8	781053
7.1	Coupling Post 0.5 m VRB	125746	70	<b>Climbing Rails</b>	
7.2	Coupling Post 1.0 m VRB	125756	70.1	Climbing Rail RCS 148	114166
8	Eye Nut DW 20 VRB	125727	70.2	Climbing Rail RCS 248	109469
9	Articulated Spanner DW 20 VRB	125741	70.3	Climbing Rail RCS 348	109470
10	Tie Rod DW 20, Special Length	030700	70.4	Climbing Rail RCS 398	112141
11	Eye Nut RCS DW 15	115378	71	Cross Connector RCS	123509
12	Articulated Spanner RCS DW 15	115375		<b>PERI UP Connection</b>	
13	Tie Rod DW 15, Special Length	030030	80	Connector UP-VRB	126355
	<b>Bearings</b>		81	Bracket Connector UP-VRB	126345
20	Centering Plate HDT-VRB	128019		<b>PERI UP</b>	
21	Cross Fall Bearing VRB	127136	90	Top Standard UVH 150	100003
22	Longitudinal Bearing VRB	127143	91	Ledger UH 75 Plus	114629
23	Horizontal Bearing-2 VRB	131852	92	Ledger UH 100 Plus	114632
24	Cross Fall Adapter VRB	131031	93	Ledger UH 300 Plus	114651
	<b>Bracing Traverses</b>		94	Steel Deck UDG 25 x 300	124915
30	Bracing Traverse 150 VRB	128091	95	Top Standard UVH 100	100000
31	Bracing Traverse Connector VRB	128103	96	Console Bracket UCM 75 with Spigot	112678
32	Bracing Spindle VRB	128098			
35	<b>Main Beams</b>				
35.1	Main Beam 350 VRB	126059			
35.2	Main Beam 500 VRB	126062			
35.3	Main Beam 800 VRB	126065			
36	Main Beam Connector VRB	126050			

Tool name
Ratchet Wrench
Extension for the Ratchet Wrench
Wrench Socket SW 36
Allen Key SW 6 / SW 8 / SW 10
Spirit Level
Cordless Screwdriver
Screw Bits TORX 25, 30
Ring / Open-End Wrench SW 13 / SW 16 / SW 18 / SW 24 / SW 30 / SW 36
4-Sling Lifting Gear
Circular Saw
Torque Wrench
Hammer
Round Slings

## Tightening Torque

For the screw connections, PERI recommends the following "hand-tightened" tightening torque MA, hand-tightened according to Eurocode 3 and DIN EN 1090-2:

Bolt	M20	M24	M30	M36
MA, hand-tightened [Nm]	60	110	220	350

## Assembly Preparation

### General information

- The project-related assembly plan from PERI is binding for the assembly of single trusses and truss packages.
- For assembling the Heavy-Duty Truss Girder, prepare a designated area with the following features:
  - The surface must be flat and horizontal.
  - The area must be at least the size of the fully assembled truss package.
  - The area must have sufficient load-bearing capacity to accommodate the fully assembled truss package.
- Make sure that the  $\varnothing 26$  holes in the flanges of the Climbing Rail are at the bottom.
- Drive in bolts which are vertically mounted from top to bottom.
- For those bolts that are mounted horizontally, no mounting direction is prescribed. PERI recommends always mounting the bolts from the same direction.
- All bolts must be secured by means of the appropriate cotter pins.



- PERI recommends using the Climbing Rail RCS as an assembly aid. This facilitates safe assembly of the Heavy-Duty Truss Girder and its components.
- Alternatively, assembly can also take place horizontally.

## Load-Bearing Capacity



Attach the frames to the fitting pins in the top chord or with lifting straps to the crane. (Fig. A1.01).

### Bearing capacity of the load-bearing points:

- Fitting Pin  $\varnothing 21$  (44) : 2,000 kg
- Fitting Pin  $\varnothing 26$  (44) : 3,650 kg

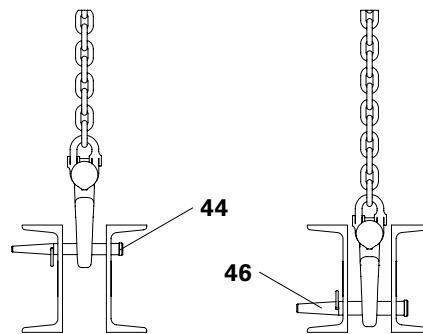

Fig. A1.01



- Take into consideration the project-specific dead weight of the truss girder.
- Alternatively, load-bearing straps with the appropriate load capacity can be used.
- The attachment points are determined through a series of tests to ensure that the frames and truss girders are in the right position when being craned in.

## Safety Instructions



### Danger

Heavy moving parts can fall down or overturn!

During assembly, there is a risk of hands and other body parts being crushed.

- ⇒ Do not stand under suspended loads.
- ⇒ Use a guide rope when moving components.
- ⇒ Maintain an appropriate safety distance.
- ⇒ Do not stand between moving elements.

## Mounting the Standard Frames

### Components

1	Standard Frame VRB	1x
---	--------------------	----

### Assembly aids for the components

40	Cotter Pin 4/1	4x
44	Fitting Pin Ø 21 x 120	4x
70	Climbing Rail RCS 398	2x
71	Cross Connector RCS	2x



- The Cross Connector can only be mounted at certain positions on the frame. Ensure that all the other components of the truss girder can also be mounted. (Fig. A1.02)
- The distance from the centre of the Cross Connector to the edge is 92.75 cm.



Detach the frame from the crane lifting gear only after all bolts have been inserted and secured.

### Mounting the assembly aids

1. For assembling the first Standard Frame (1), lay out two Climbing Rails (70).
2. Fix one Cross Connector (71) to each of the Climbing Rails by means of fitting pins (46) and secure with a cotter pin (41). (Fig. A1.02 + A1.03)

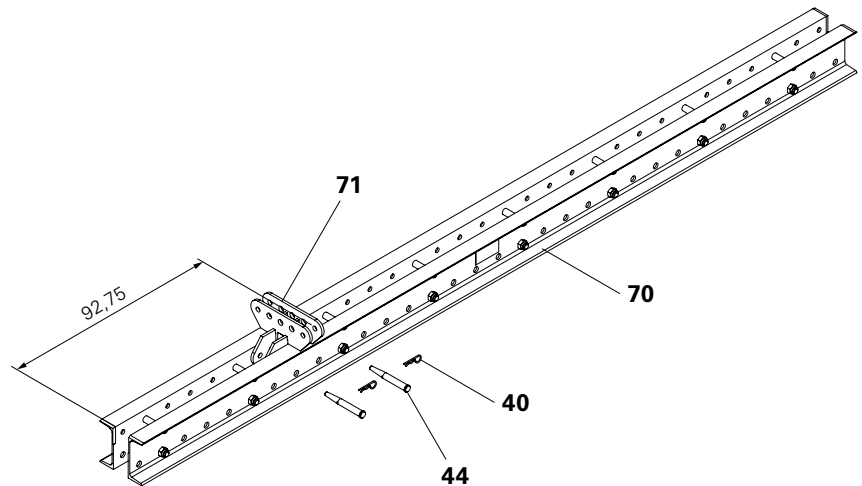

Fig. A1.02

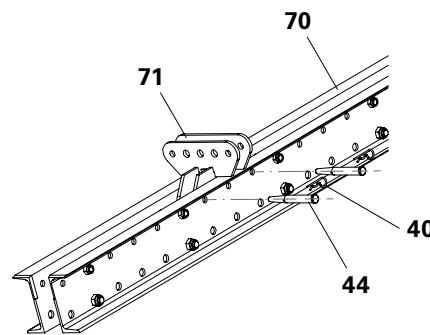

Fig. A1.03



- The Climbing Rails are positioned transverse to the direction of assembly of the single trusses or truss package.
- The Climbing Rail distance is 237.5 cm. (Fig. A1.04)
- Ensure that there is sufficient space to assemble the Bearing Frame.

## Assembly

1. Place the Standard Frame (1) over the Cross Connectors (71) using the crane and set down on the Climbing Rails (70).
2. Align the Standard Frame with the holes in the bottom chord.
3. Fix the Standard Frame using fitting pins (44) and secure with cotter pins (40).

(Fig. A1.04)

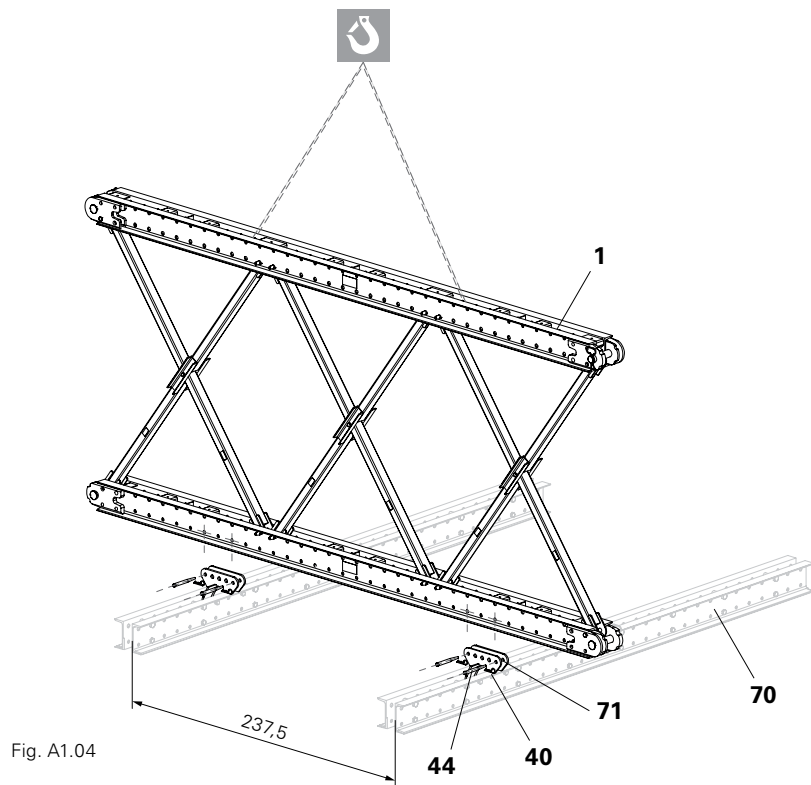

Fig. A1.04



The Climbing Rails serve as assembly aids for ensuring safe and secure assembly of the Heavy-Duty Truss Girder. It is important that the Climbing Rails are mounted as close as possible to the frame centre of gravity. However, this is not always possible because the Cross Connector cannot be mounted in this position, see Detail A. Fig. A1.05 shows a schematic view of the truss assembly complete with Bearing Frame and various Standard Frames.

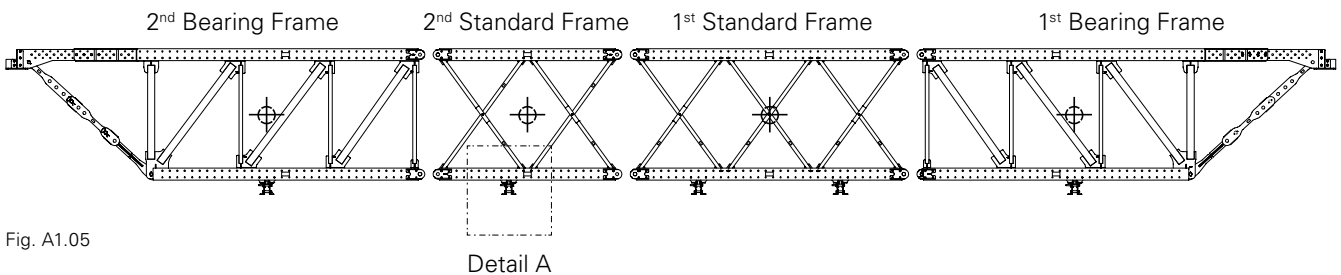

Fig. A1.05

## Connecting the Standard Frames

### Assembly

1. Lay out an additional Climbing Rail next to the first Standard Frame. The Climbing Rail must be mounted as close as possible to the centre of gravity of the second Standard Frame (1b). (Fig. A1.06)
2. Fix one Cross Connector to the Climbing Rail by means of fitting pins (46) and secure with cotter pins.



The position of the Cross Connector is the same on all Climbing Rails. (Fig. A1.02)

3. Place an additional Standard Frame (1b) over the Cross Connector using the crane and set down on the Climbing Rail. (Fig. A1.06)



### Warning

Risk of crushing through heavy moving parts!

Risk of hands being crushed when coupling the two frames.

- ⇒ Do not take hold of anything between the chord plate connections.
- ⇒ Guide the frame using only top and bottom chords.

4. Remove cotter pins (42) from both frames and pull out bolts (49).
5. Push the second Standard Frame (1b) together with the first Standard Frame (1a).

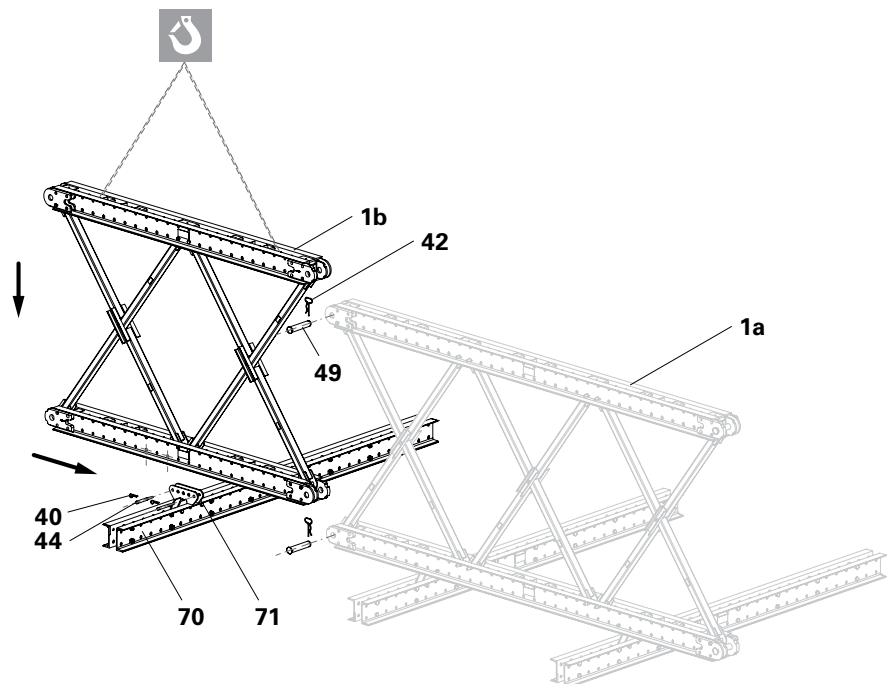

Fig. A1.06



Ensure that the single chord plate is inserted into the double chord plate in the chord plate connections of the top and bottom chords. (Fig. A1.07)

6. Connect the Standard Frames (1a + 1b) using two bolts (49) and secure each with a cotter pin (42). (Fig. A1.07)
7. Align the Climbing Rail with the holes in the bottom chord of the Standard Frame and the Cross Connector.
8. Fix the Standard Frame on the Cross Connector using fitting pins and secure with cotter pins.
9. Mount all additional Standard Frames in the same way as specified in the assembly plan.

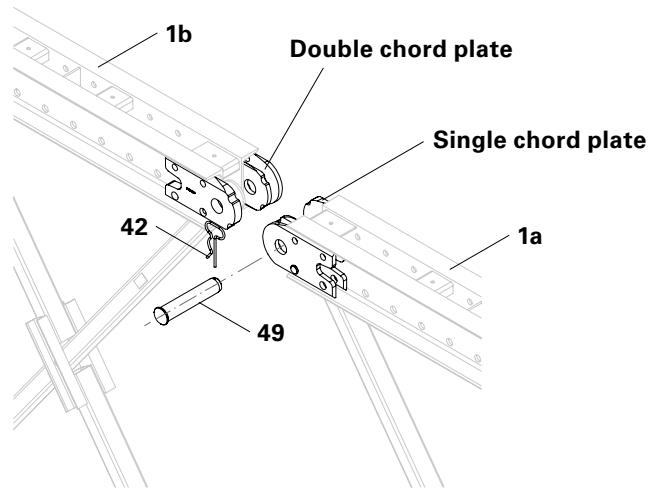

Fig. A1.07

## Connecting the Bearing Frames

### Components

- 2 Bearing Frame
- 40 Cotter Pin 4/1
- 42 Cotter Pin 6/1 Ø 50 VRB
- 44 Fitting Pin Ø 21 x 120
- 49 Bolt Ø 50 x 250



Detach the frame from the crane lifting gear only after all bolts have been inserted and secured.

### Assembly

1. Lay out one Climbing Rail (70) next to the first Standard Frame (1). The Climbing Rail must be positioned under the centre of gravity of the Bearing Frame (2).
  2. Fix one Cross Connector (71) to the Climbing Rail by means of fitting pins (44) and secure with cotter pins (41).
  3. Place the Bearing Frame over the Cross Connector using the crane and set down on the Climbing Rail.
  4. Remove cotter pins (42) from both frames and pull out bolts (49).
- (Fig. A1.08)

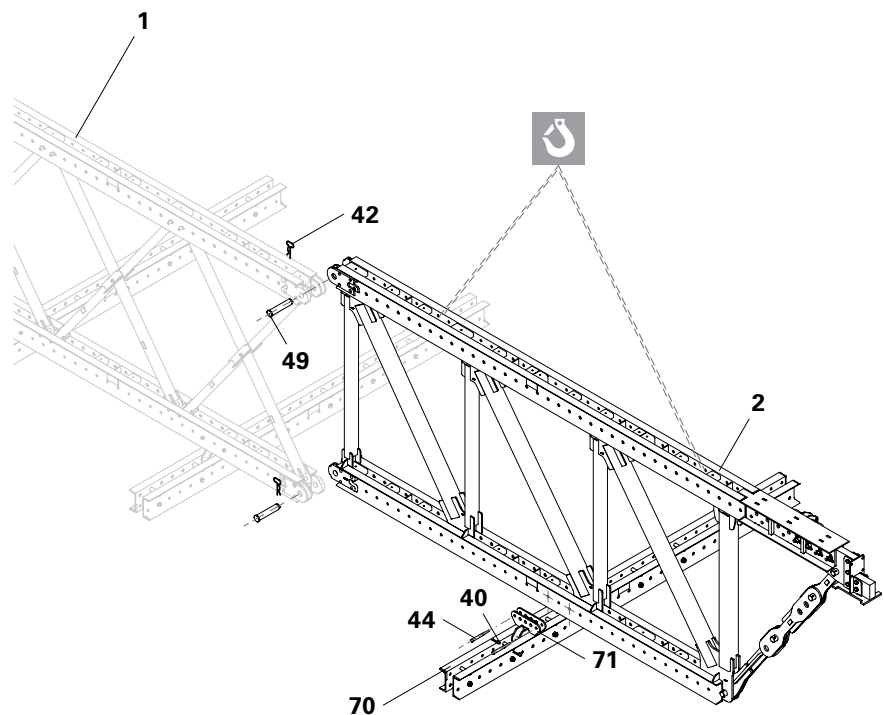

Fig. A1.08



## Warning

Risk of crushing through heavy moving parts!

Risk of hands being crushed when coupling the two frames.

- ⇒ Do not take hold of anything between the chord plate connections.
- ⇒ Guide the frame using only top and bottom chords.

5. Connect the Bearing Frame (2) to the Standard Frame (1).



Ensure that the single chord plate is inserted into the double chord plate in the chord plate connections of the top and bottom chords (Fig. A1.09).

6. Connect both frames using two bolts (49) and secure each bolt with a cotter pin (42).
7. Align the Climbing Rail with the holes in the bottom chord of the Bearing Frame and the Cross Connector.
8. Fix the Bearing Frame on the Cross Connector using fitting pins (44) and secure with cotter pins (40).
9. Mount the second Bearing Frame at the other end of the single girder in the same way.

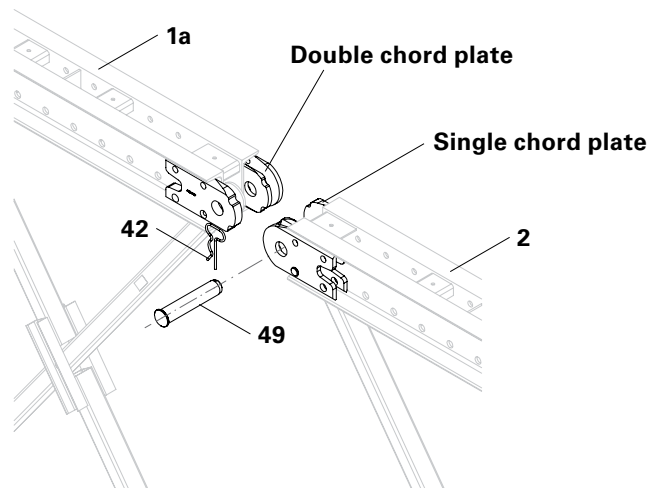

Fig. A1.09

## Adjusting the Bearing Frames

The Bearing Frame consists of:

- top chord
- bottom chord
- vertical struts
- diagonal struts
- telescopic box

(Fig. A1.10)

The Telescopic Box VRB consists of:

- Tension profile (2.3)
- Telescopic arm (2.4)
- Telescopic arm guide (2.5)

With the help of the telescopic arm, the Bearing Frame can be extended in six increments of 12.5 cm.

The Bearing Frame can be extended by a total of 75 cm.

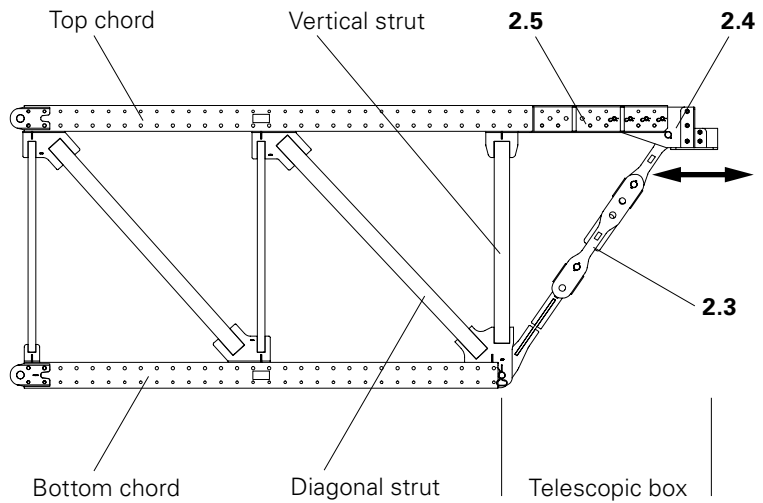

Fig. A1.10



- ⇒ The four fitting pins (47) must be mounted in the four outer holes of the telescopic arm guide (2.5).
  - ⇒ Also when fully extended, all four fitting pins (47) must be securely mounted.
  - ⇒ The telescopic arm (2.4) must always be fixed with all four fitting pins (47).
- (Fig. A1.11)

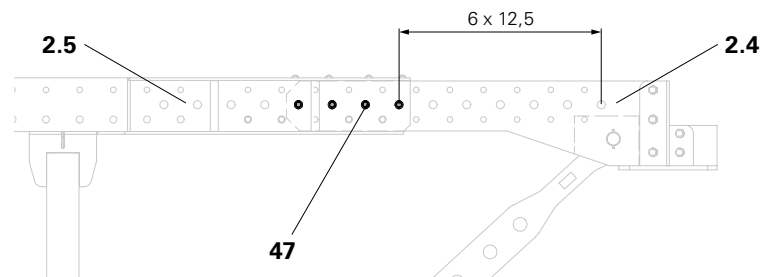

Fig. A1.11



It is helpful having a second person to assist in carrying out the following steps.

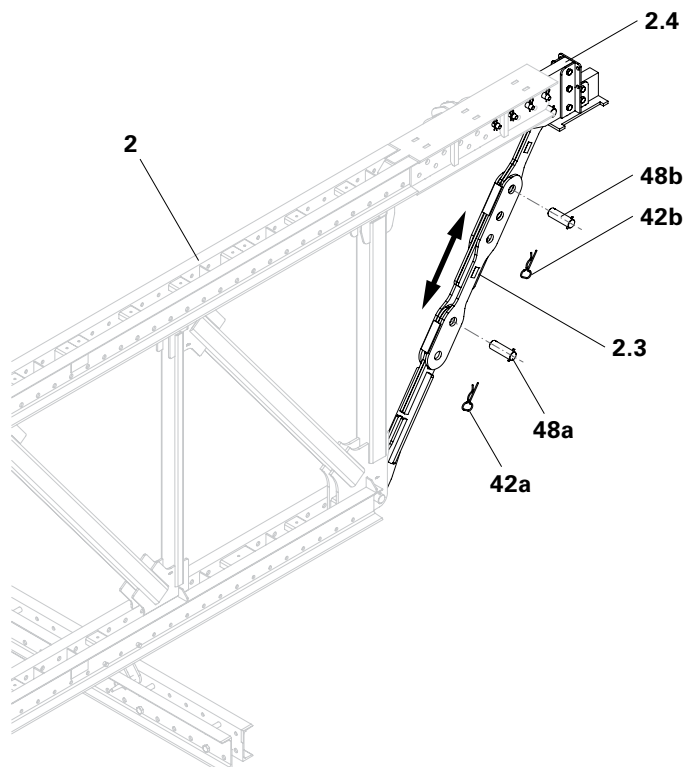

Fig. A1.12

## Components

- 41 Cotter Pin 5/1
- 42 Cotter Pin 6/1 Ø 50 VRB
- 47 Fitting Pin Ø 30 VRB
- 48 Bolt Ø 50 x 155

## Assembly

1. Remove cotter pins (42a) and (42b). (Fig. A1.12)
2. Pull out bolts (48a) and (48b).
3. Move tension profile (2.3) until the required position of the bolt (48a) corresponds to the positioning matrix. (Fig. A1.15)

### Warning

Heavy moving components!

These can fall down or cause hands to be crushed.

- ⇒ Move tension profile carefully thus ensuring that it does not slide out of the guide.
- ⇒ Keep hands well away from the holes on the tension profile.
- ⇒ Wear protective gloves and safety shoes.

4. Insert bolts (48a) and secure with cotter pins (42a). (Fig. A1.12)
5. Remove cotter pin (41) and pull out fitting pin (47). (Fig. A1.13)
6. Adjust the telescopic arm (2.4) to the required length. The tension profile (2.3) is automatically adjusted to the correct length.
7. Insert fitting pin (47) and secure with cotter pin (41).
8. Insert bolt (48b) and secure with cotter pin (42b).

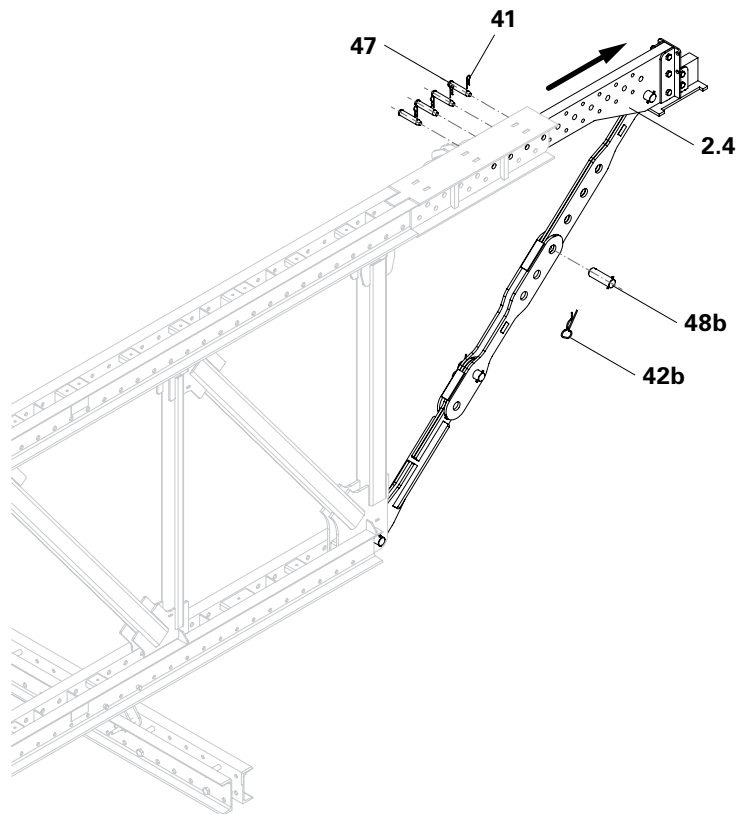

Fig. A1.13

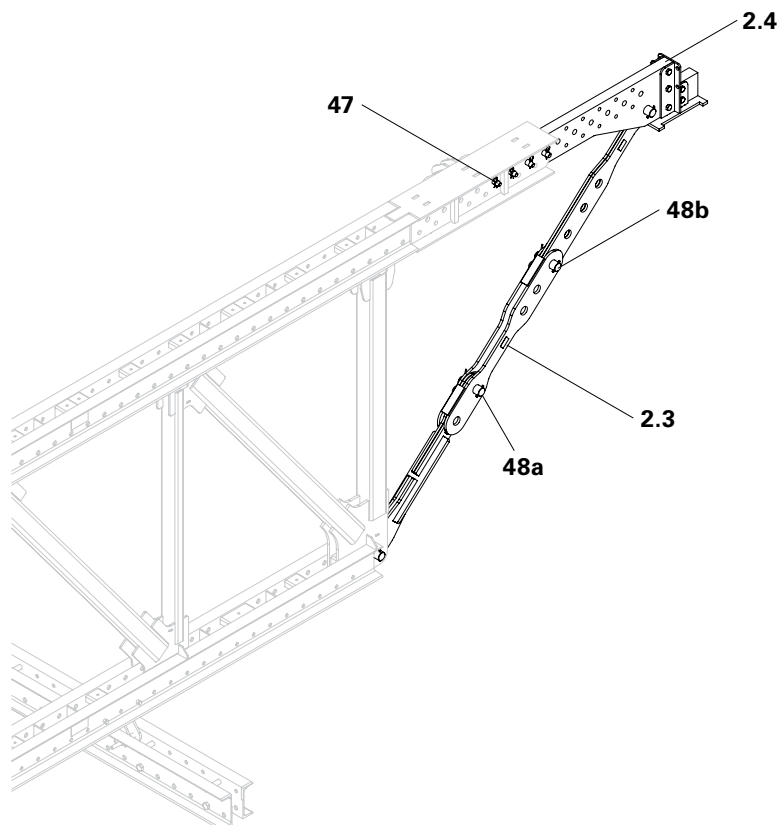

Fig. A1.14

# A1 Assembly of the Frame

Fig. A1.15 shows the positions for inserting bolts 48a and 48b depending on the extension of the telescopic arm.

Assembly of the frame is now complete.

If a truss package is to be mounted, see Section "A2 Assembly of the Truss Package" on Page 24.

If a single truss is to be mounted, see Section "Assembly of Single Trusses" on page 35.

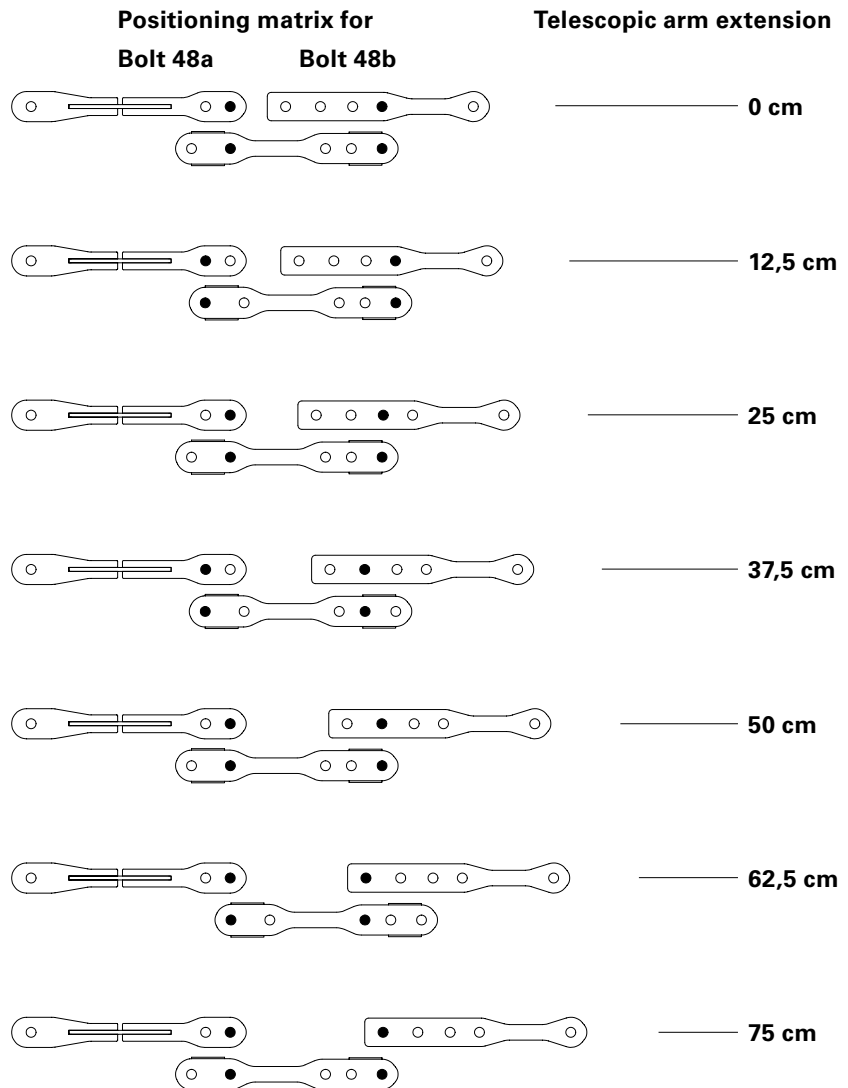

Fig. A1.15

## Mounting the Bracing Shoes

### Components

- 3** Bracing Shoe VRB
- 4** Vertical Bracing Shoe VRB
- 5** Coupling Shoe VRB
- 52** Bolt ISO 4014 M20 x 150-8.8
- 62** Nut ISO 7040 M20-8

### Assembly for Bearing Frame 6.0 m VRB

1. Position Bracing Shoe (3) directly next to the fitting pin (47).
2. Fix with bolt (52) and nut (62).
3. Alternately mount a Bracing Shoe (3) and a Vertical Bracing Shoe (4) on the top chord. The spacing is 150 cm in each case.
4. Mount Vertical Bracing Shoes (4) on the bottom chord in the same way. The position corresponds to the Vertical Bracing Shoes (4) on the top chord. The spacing is 300 cm in each case.

(Fig. A2.01 + A2.03)

### Assembly for Bearing Frame 5.25 m VRB

1. Position the Bracing Shoe (3) directly above the first vertical strut.
2. Further assembly corresponds to the Bearing Frame 6.0 m as of Step 2.

(Fig. A2.02 + A2.03)

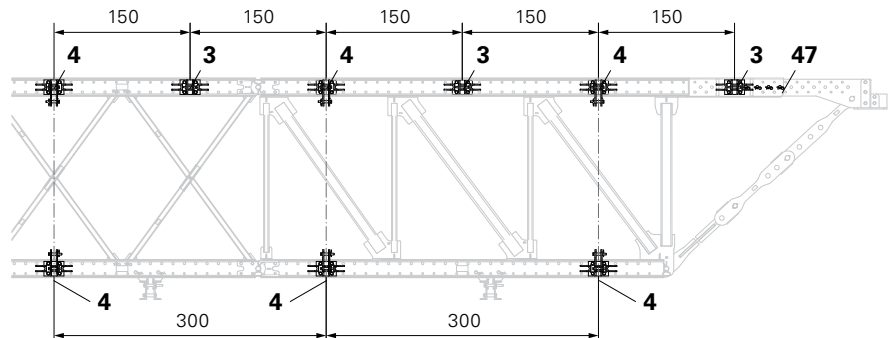

Fig. A2.01

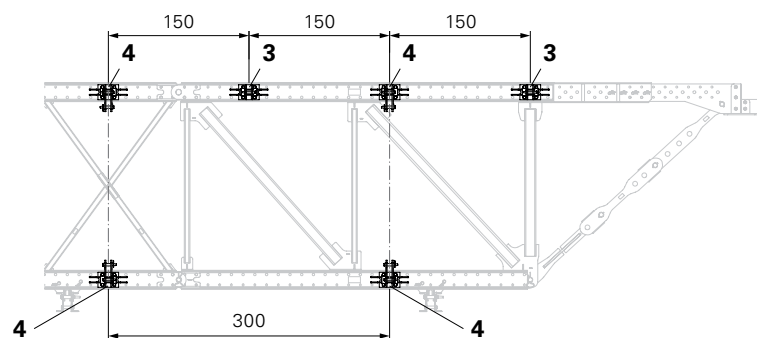

Fig. A2.02

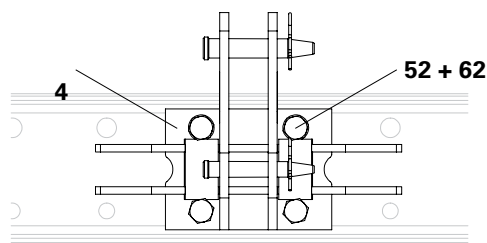

Fig. A2.03

# A2 Assembly of the Truss Package

## Connecting a single truss

When connecting a single truss to the truss package, Coupling Shoes (5) must be mounted on the rear.

In this case, a Coupling Shoe (5) is mounted together with a Bracing Shoe (3) or Vertical Bracing Shoe (4) on the top and bottom chords.

(Fig. A2.04 + A2.04a)

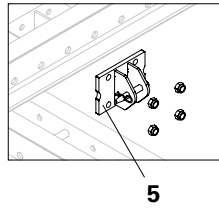

Fig. A2.04a



Mount the connections for the PERI UP Flex system together with the Bracing Shoes. See Section "D1 Installation of PERI UP Flex" on Page 52.

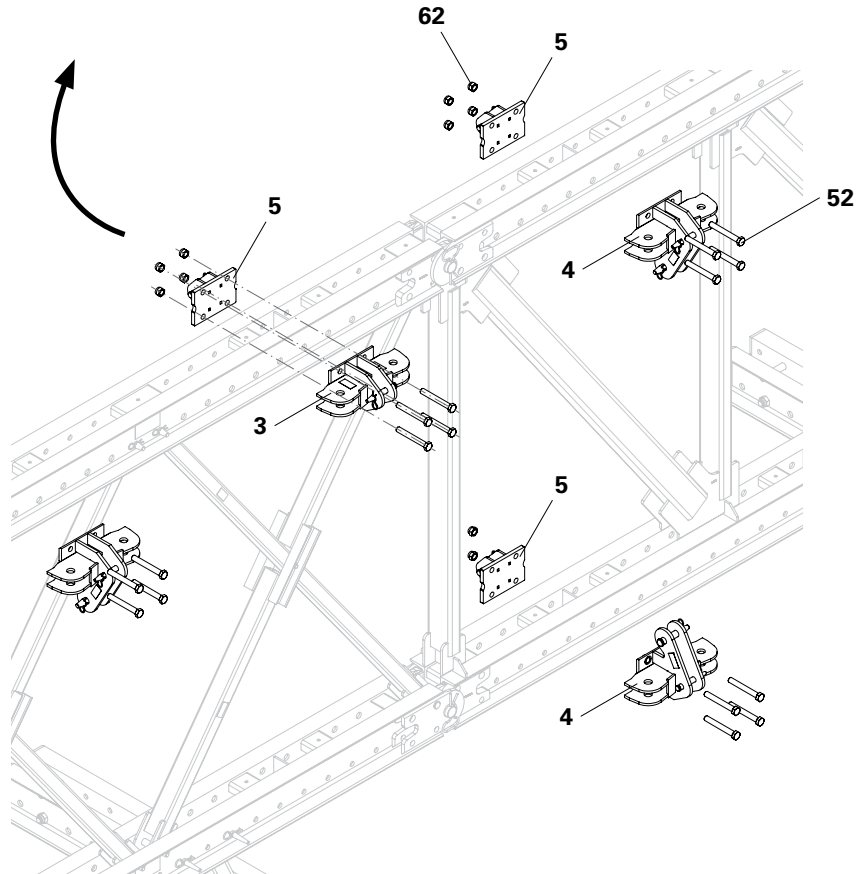

Fig. A2.04

## Mounting the Bracing Posts

### Components

- 6.1** Bracing Post 1.50 m VRB
- 40** Cotter Pin 4/1
- 43** Fitting Pin Ø 21 x 105 VRB

### Assembly

1. Attach a Bracing Post (6.1) to each Bracing Shoe (3) using fitting pins (43) and secure with cotter pins (40).
2. Attach a Bracing Post (6.1) to each Vertical Bracing Shoe (3) using fitting pins (43) and secure with cotter pins (40).

(Fig. A2.05 + A2.06)

## Mounting the Second Frame



The assembly of the bracing components takes place inversely to those of the first single truss.

Mount a second single truss on the Climbing Rail (70) in the same way.  
(Fig. A2.06)

The spacing to the first single truss is axis - axis 150 cm.

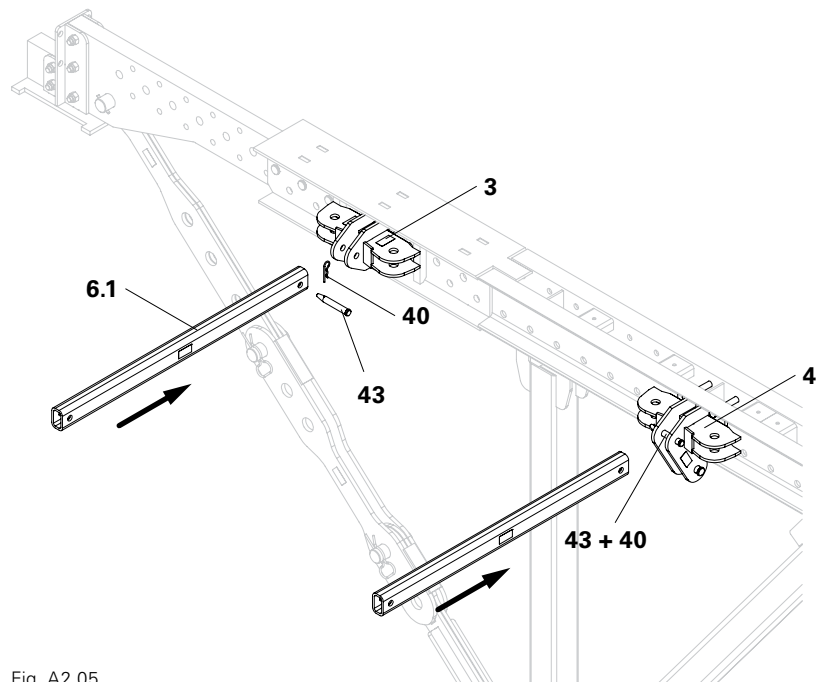

Fig. A2.05

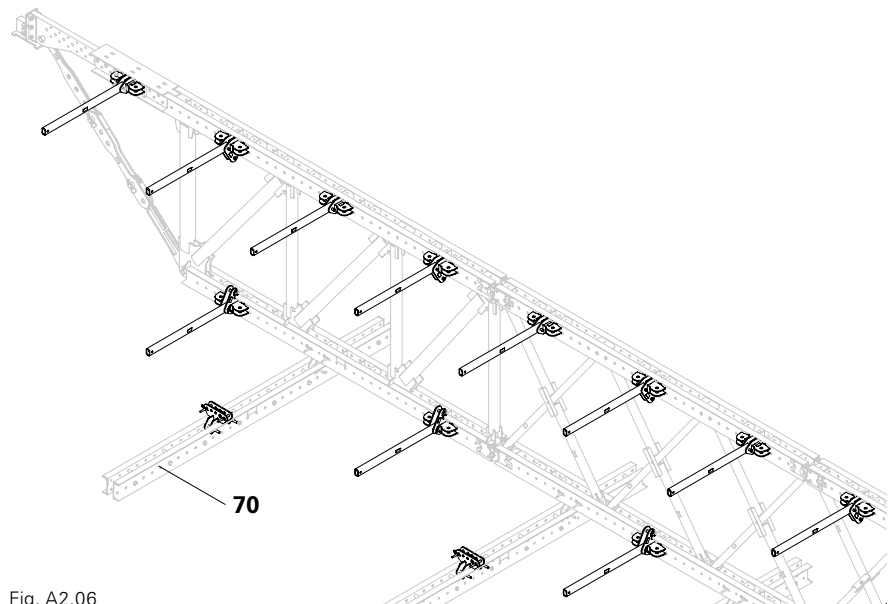

Fig. A2.06

## Connecting Both Single Trusses

### Components

- 40** Cotter Pin 4/1
- 43** Fitting Pin  $\varnothing$  21 x 105 VRB

### Assembly

1. Fix all pre-assembled Bracing Posts (6.1) to the second single truss using fitting pins (43) and secure with cotter pins (40). (Fig. A2.07)

For a better presentation, Fig. A2.07 has been rotated by 180°.

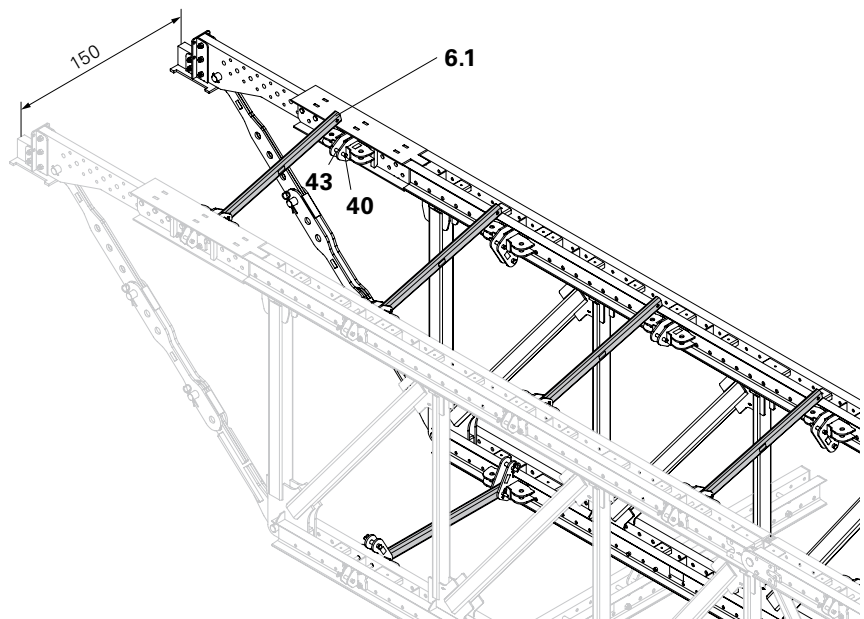

Fig. A2.07

### Front view of the truss package assembly

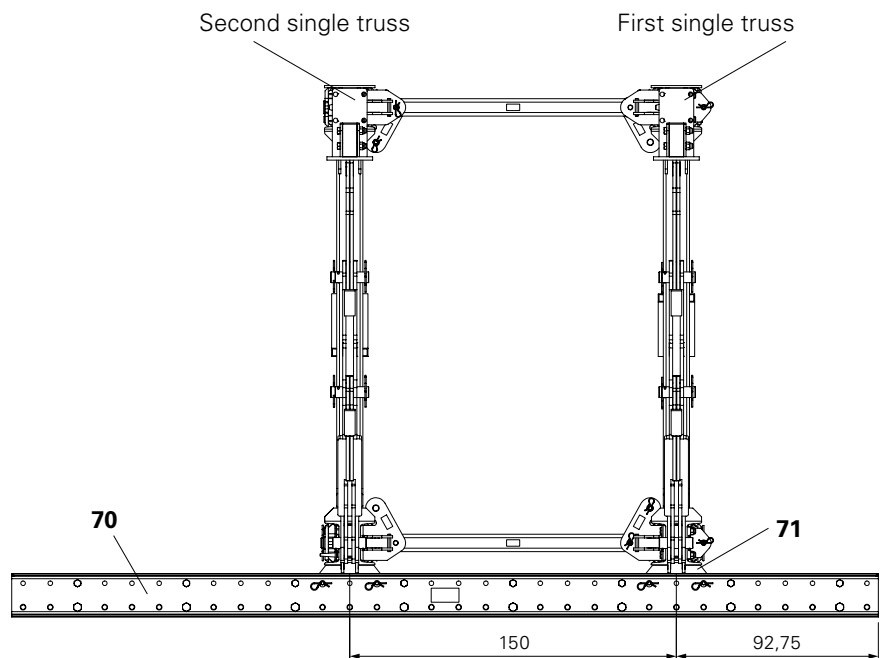

Fig. A2.08

## Mounting the Bracing Traverse



Mount the Bracing Traverse at both ends of the truss package.

### Components

- 30** Bracing Traverse 150 VRB
- 31** Bracing Traverse Connector VRB
- 32** Bracing Spindle VRB
- 40** Cotter Pin 4/1
- 45** Fitting Pin  $\varnothing$  26 x 105 VRB

### Assembly

1. Fix Bracing Spindle (32) to the Bearing Frame (2) using four bolts (32.2) and nuts (32.3). (Fig. A2.09)
2. Unscrew front nut (32.1).
3. Fix two Bracing Traverse Connectors (31) to the Bracing Traverse (30) with the bolts (45) and secure with cotter pins (40). (Fig. A2.10) The exact connection position is specified in the assembly plan.
4. Attach the assembled Bracing Traverse to the crane lifting gear using four straps.
5. Position the Bracing Traverse in front of the Bracing Spindle, and then slide on to the Bracing Spindle.
6. Secure the Bracing Traverse with the Nuts (32.1). (Fig. A2.11)

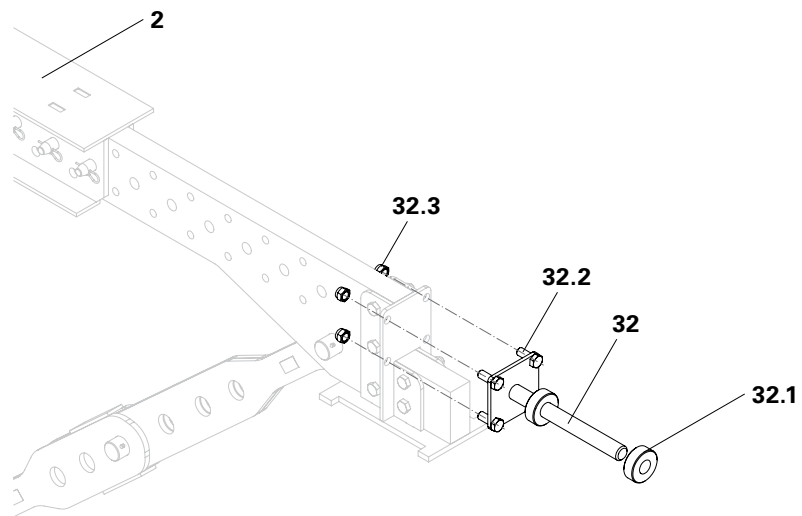

Fig. A2.09

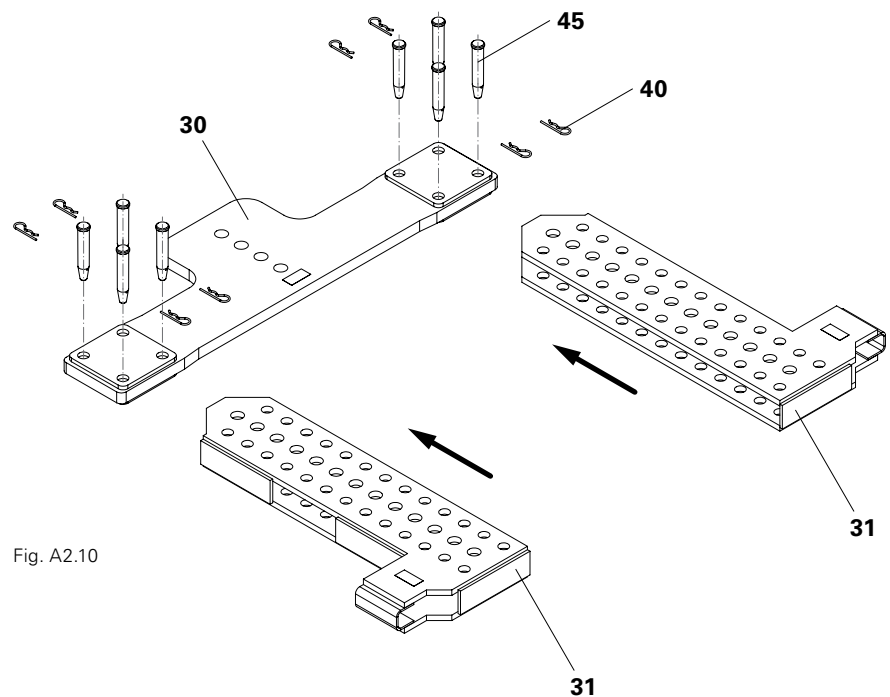

Fig. A2.10



For bridge crossing angles, adjust the Bracing Traverse and Telescopic Box. See Section "C3 Support Situation for Crossing Angle" on Page 50.

## Mounting the Horizontal Bracing

### Components

- 8 Eye Nut DW 20 VRB
- 9 Articulated Spanner DW 20 VRB
- 10 Tie Rod DW 20, Special Length
- 40 Cotter Pin 4/1
- 47 Fitting Pin Ø 30 VRB
- 61 Nut DW 20 SW 36/60



With a frame spacing of 150 cm, the tie rod has a length of 157 cm for the horizontal bracing.

### Assembly of the eye nut

1. Screw the tie rod (10) into the eye nut (8). (Fig. A2.12)



Has the tie rod been completely screwed in the eye nut?

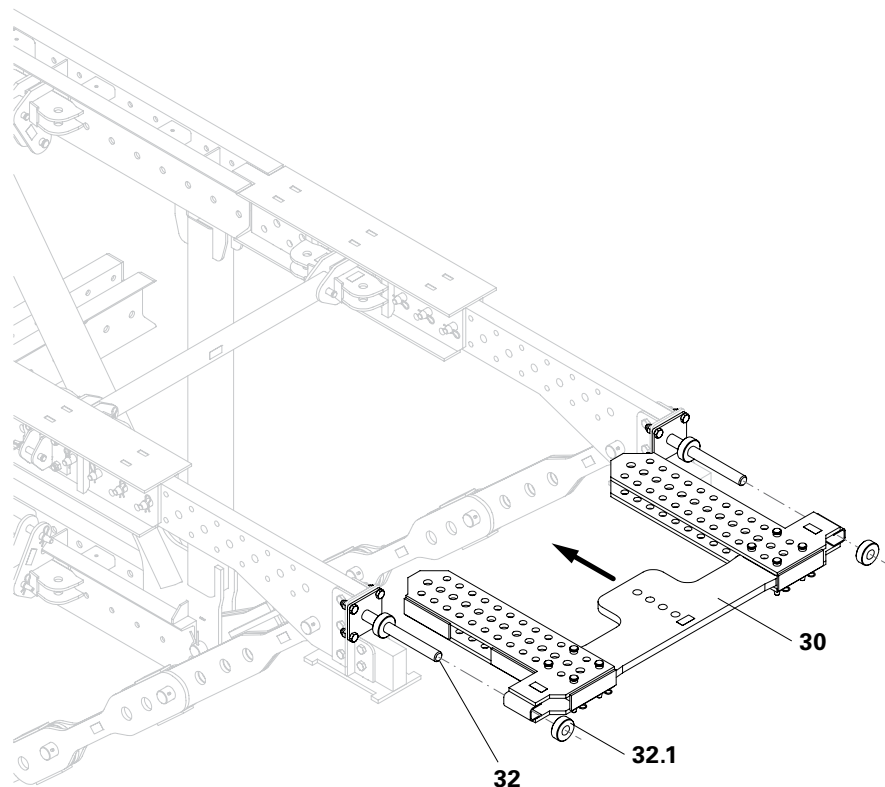

Fig. A2.11

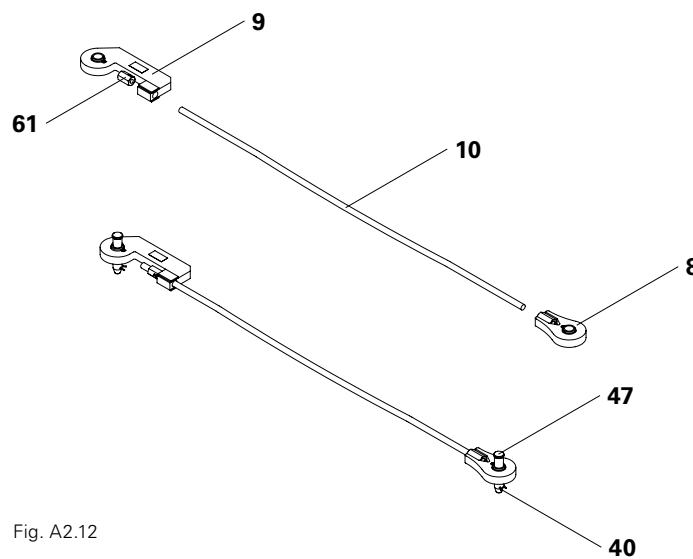

Fig. A2.12

## Assembly of the Articulated Spanner

1. Insert the Articulated Spanner (9) into the Bracing Shoe horizontal connections (3), Vertical Bracing Shoes (4) and the Bracing Traverse connections (31). (Fig. A2.13)
2. Fix Articulated Spanner with bolts (47) and secure with cotter pins (40).

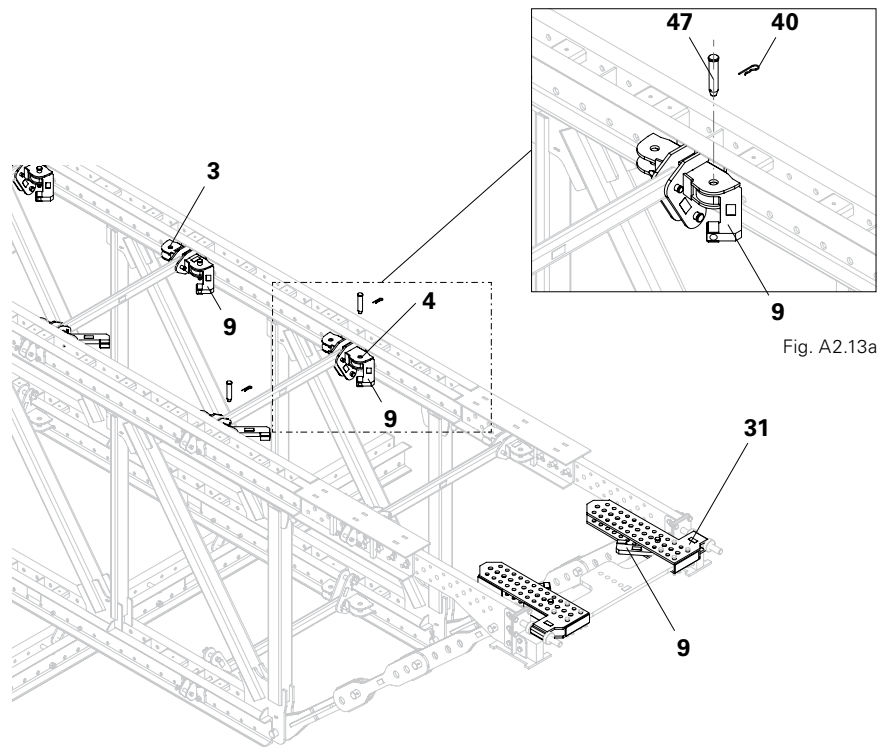

Fig. A2.13a

## Assembly of the Tie Rod

1. Insert tie rod (10) into the Articulated Spanner.
2. Screw nut (61) onto the tie rod until it no longer protrudes.
3. Push the tie rod as far as possible into the Articulated Spanner.
4. Swivel eye nut (8) diagonally opposite into the Bracing Shoe (3) or Vertical Bracing Shoe (4). (Fig. A2.14)
5. Fix eye nut in position with bolts (47) and secure with cotter pins (40).
6. Tighten all nuts (61) on the Articulated Spanner (9) with a wrench and adjust the bracing struts so they are free of play. (Fig. A2.15)

Fig. A2.13



The tie rod projection on the nut must be at least 10 mm.



- Have all connections been mounted on the Bracing Shoes and Vertical Bracing Shoes?
- Have all fitting pins been inserted and secured with cotter pins?
- Have all bracing struts been adjusted to ensure they are free of play?

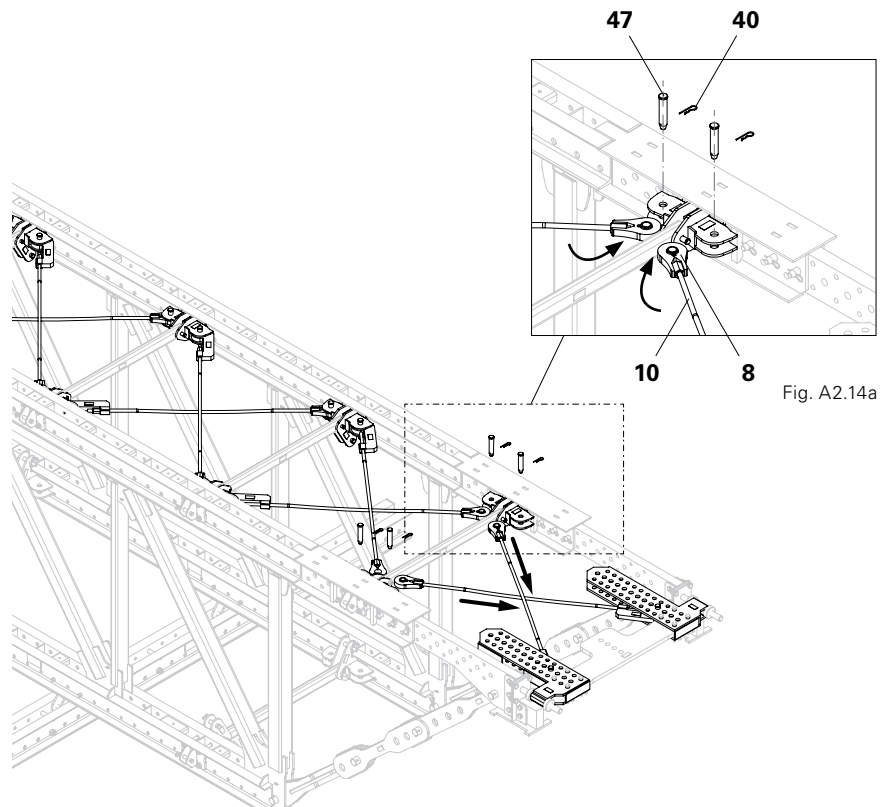

Fig. A2.14a

Fig. A2.14



## Assembly on the Bearing Frame

- Always mount the Articulated Spanner as close as possible to the Bracing Traverse. Consider the individual position specified in the project planning.
- Individually adjust the tie rod to suit the bridge crossing angle and position of the Bracing Traverse. See Section "C3 Support Situation for Crossing Angle" on Page 50.



For a support situation with longitudinal or lateral inclinations, the nuts must not be play-free adjusted. In this case, only attach the nuts. See Section "C1 Support Situation for Longitudinal Inclinations" on Page 48 and Section "C2 Support Situation for Lateral Inclinations" on Page 49.

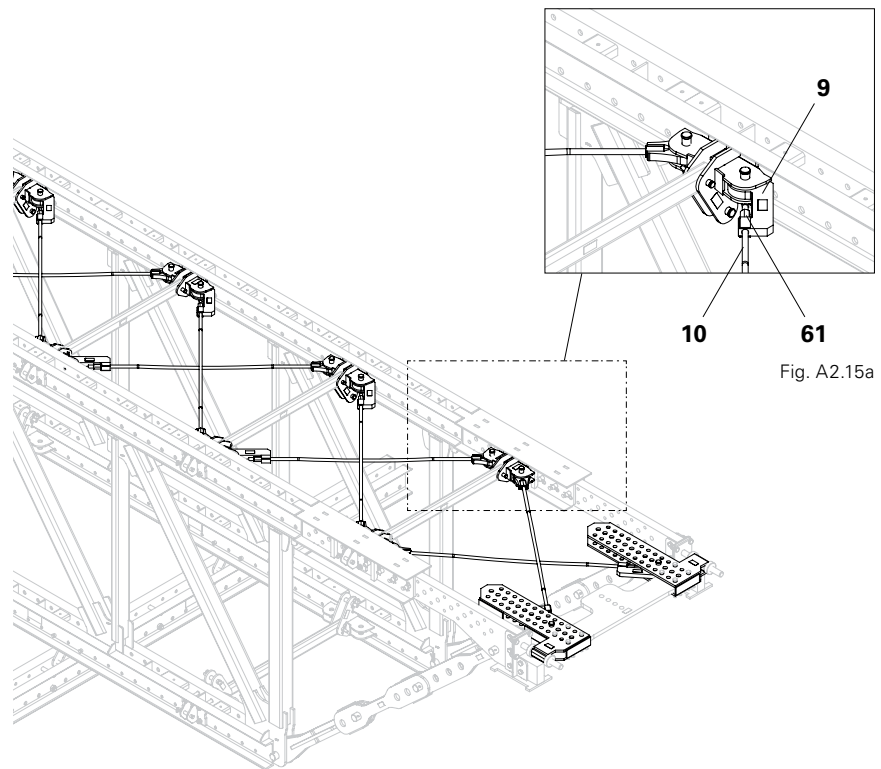

Fig. A2.15a

Fig. A2.15

## Mounting the Vertical Bracing

### Components

- 11 Eye Nut RCS DW 15
- 12 Articulated Spanner RCS DW 15
- 13 Tie Rod DW 15, Special Length
- 40 Cotter Pin 4/1
- 45 Fitting Pin Ø 26 x 105 VRB
- 60 Hex. Nut DW 15 SW 30/50



With a frame spacing of 150 cm, the tie rod has a length of 195 cm for the vertical bracing.

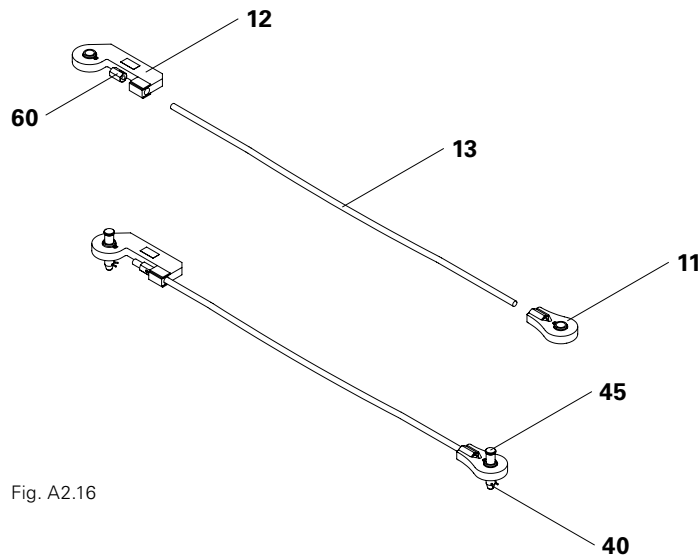

Fig. A2.16

### Assembly of the eye nut

1. Screw tie rod (13) into the eye nut (11) (Fig. A2.16).



Has the tie rod been completely screwed in the eye nut?

### Assembly of the Articulated Spanner

1. Insert the Articulated Spanner (12) into the vertical chord plates of the Vertical Bracing Shoes (4) in the top chord. (Fig. A2.17)
2. Fix Articulated Spanner with fitting pins (45) and secure with cotter pins (40).

### Assembly of the tie rod

1. Insert tie rod (13) into the Articulated Spanner. (Fig. A2.18)
2. Screw nut (60) onto the tie rod until it no longer protrudes.
3. Push the tie rod as far as possible into the Articulated Spanner.

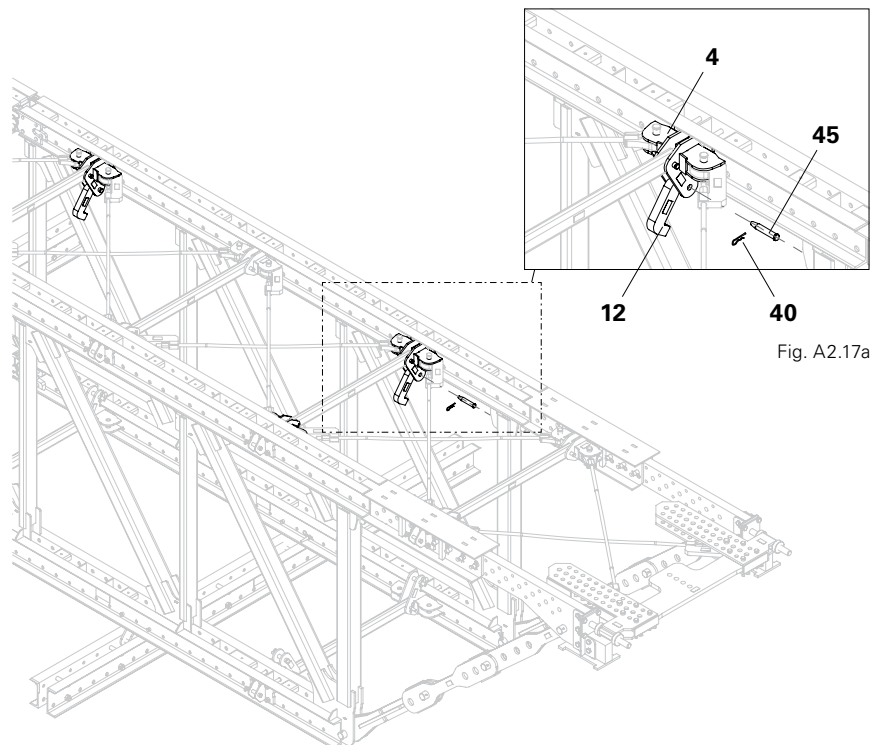

Fig. A2.17a

Fig. A2.17

4. Swivel eye nut (11) diagonally opposite into the Vertical Bracing Shoe (4) in the bottom chord.
5. Fix eye nut in position with bolts (45) and secure with cotter pins (40).
6. Tighten all nuts (60) on the Articulated Spanner with a wrench and adjust the bracing struts so they are free of play. (Fig. A2.19)



The tie rod projection on the nut must be at least 10 mm.



- Have all connections been mounted on the Vertical Bracing Shoes?
- Have all fitting pins been inserted and secured with cotter pins?
- Have all bracing struts been adjusted to ensure they are free of play?



For a support situation with longitudinal or lateral inclinations, the nuts must not be play-free adjusted. In this case, only attach the nuts. See Section "C1 Support Situation for Longitudinal Inclinations" on Page 48 and Section "C2 Support Situation for Lateral Inclinations" on Page 49.

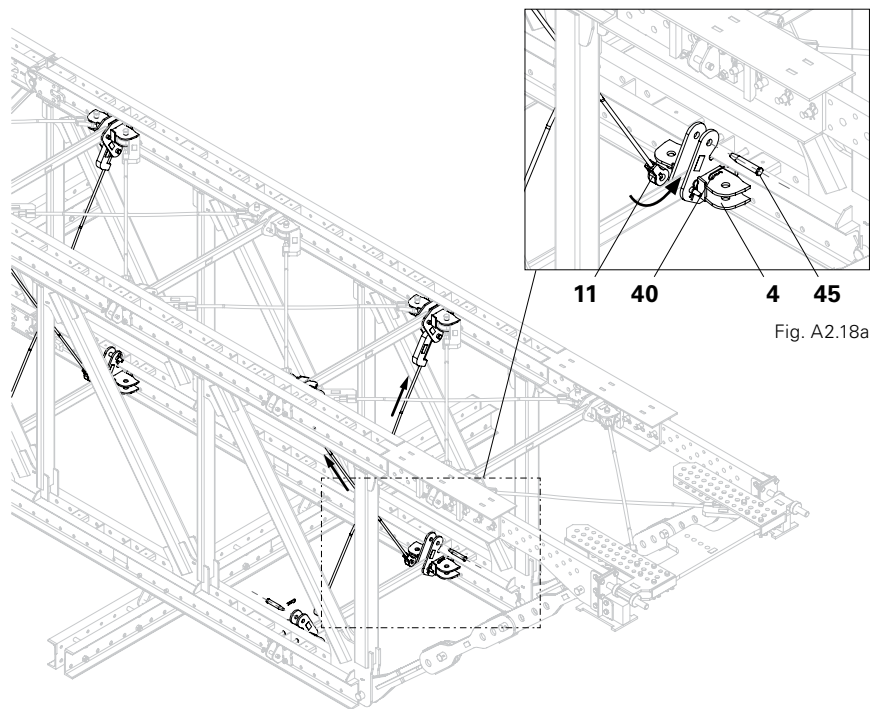

Fig. A2.18

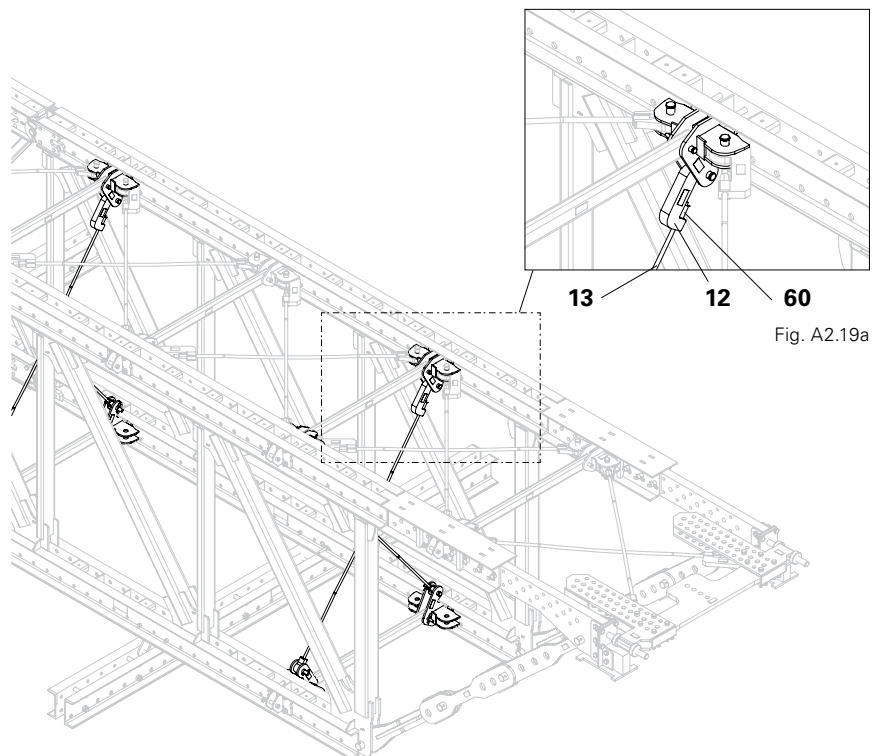

Fig. A2.19

## Coupling with a Single Truss

### Components

- 7 Coupling Posts
- 40 Cotter Pin 4/1
- 43 Fitting Pin Ø 21 x 105 VRB

This work step is omitted if no single truss is to be coupled to the truss package.

If a single truss is connected to this truss package, the Coupling Posts have already been mounted on the truss package. This facilitates on-site assembly of the package.

### Pre-assembly

The Coupling Shoes (5) should already be mounted on the top and bottom chords. See Section "Connecting a Single Truss" on page 25.

### Assembly

1. Fix Coupling Posts (7) to the Coupling Shoe (5) using fitting pins (43) and secure with cotter pins (40). (Fig. A2.20)

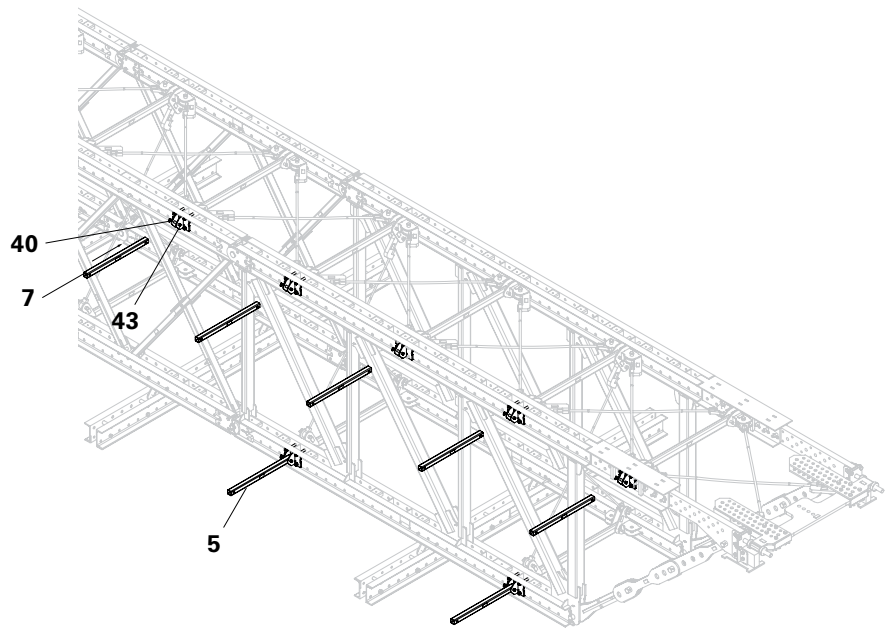

Fig. A2.20

## Mounting the Coupling Shoes

### Components

- 5** Coupling Shoe VRB
- 52** Bolt ISO 4014 M20 x 150-8.8
- 62** Nut ISO 7040 M20-8

### Assembly with Bearing Frame 6.0 m VRB

1. Position Coupling Shoe (3) directly next to the fitting pin (47).
2. Fix with bolt (52) and nut (62).
3. Install Coupling Shoes in the top chord at spacings of 150 cm.
4. Mount Coupling Shoes (5) in the bottom chord in the same way. The spacing is 300 cm in each case. (Fig. A3.01 + A3.03)

### Assembly with Bearing Frame 5.25 m VRB

1. Position the Coupling Shoe (3) directly above the first vertical strut.
2. Further assembly corresponds to the Bearing Frame 6.0 m as of Step 2. (Fig. A3.02 + A3.03)

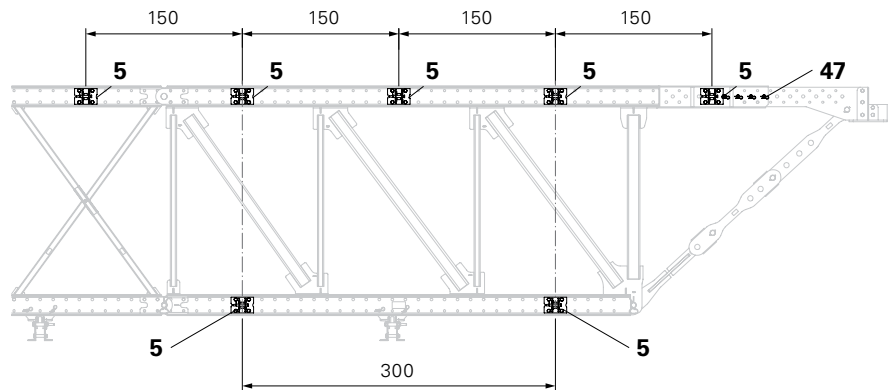

Fig. A3.01

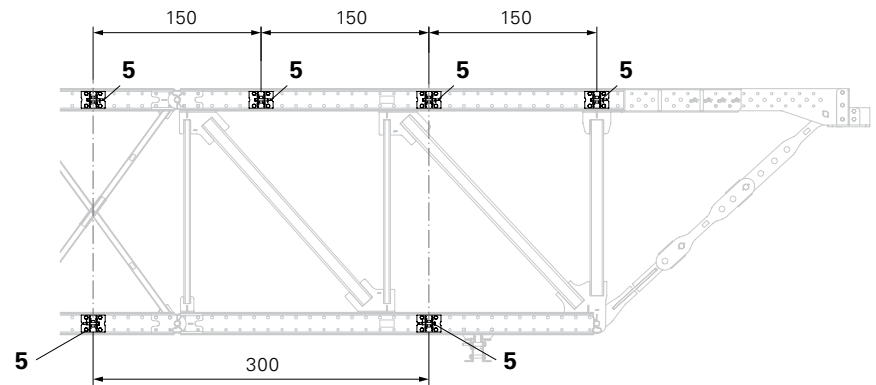

Fig. A3.02

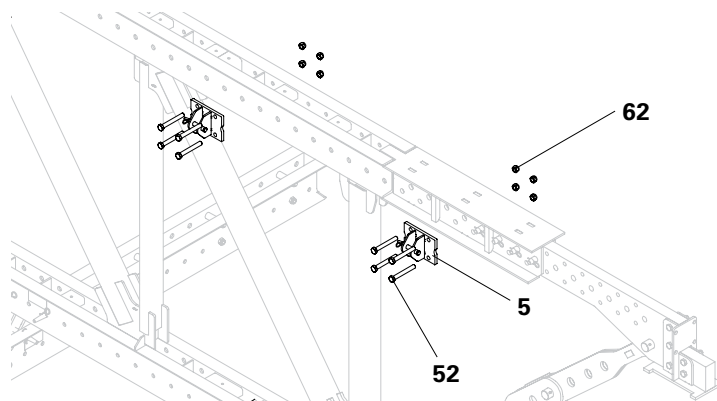

Fig. A3.03



## When connecting a single truss or truss package

- When connecting a single truss or truss package, a Coupling Shoe (5) must likewise be mounted on the rear. Mount this together with the Coupling Shoe (5) of the front side. (Fig. A3.04)
- If a single truss or truss package is coupled to this single truss, the Coupling Posts (7) are mounted on the truss package. This facilitates on-site assembly of the package. (Fig. A3.05)

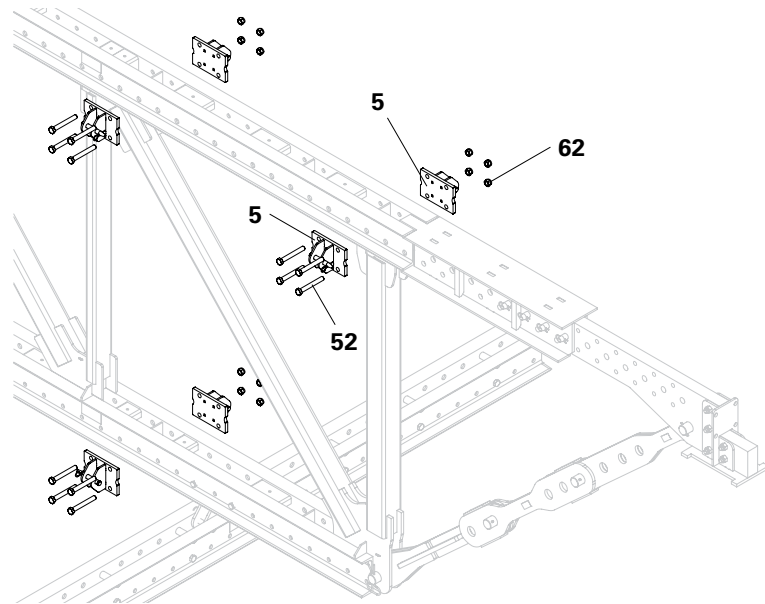

Fig. A3.04

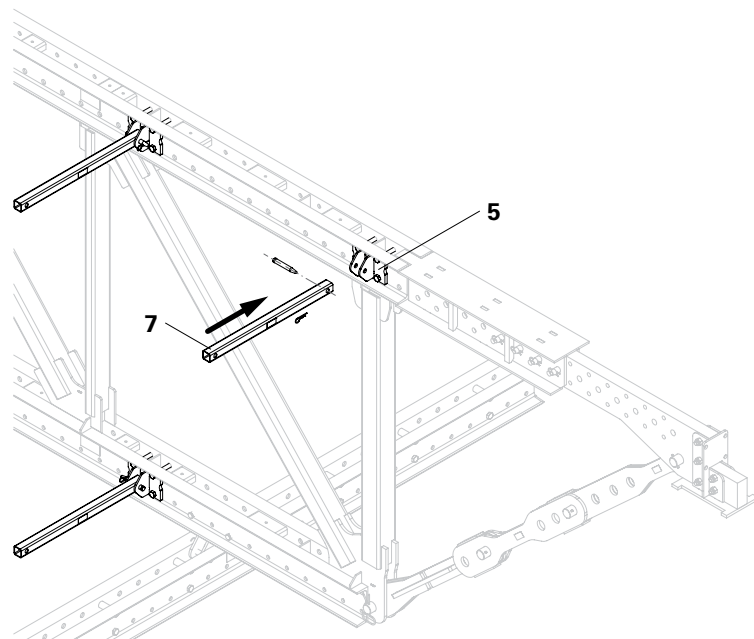

Fig. A3.05

## Mounting the Horizontal Bearing

### Components

- |           |                          |
|-----------|--------------------------|
| <b>23</b> | Horizontal Bearing-2 VRB |
| <b>35</b> | Main Beam                |

### Assembly

1. Centrally place the Horizontal Bearing (23) on the Main Beam (35) so that the holes of the Main Beam (35) and Horizontal Bearing (23) lie flush above each other.
2. Mount the Horizontal Bearing (23) on the Main Beam (35) with the four bolts (23.1) and nuts (23.8). (Fig. A4.01)
3. Secure the Horizontal Bearing (23) additionally with the clamps (23.2). (Fig. A4.02)

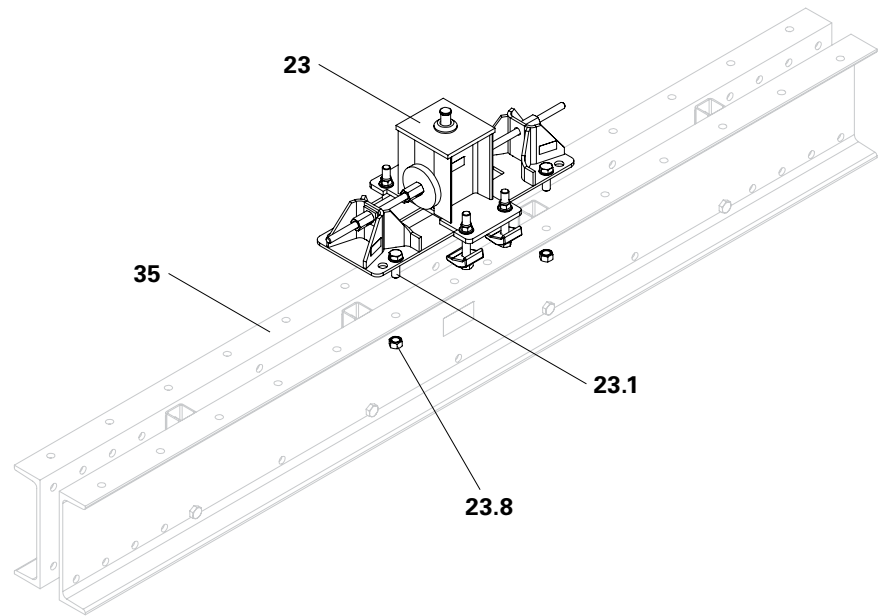

Fig. A4.01

### Aligning the Horizontal Bearing

1. Loosen all hex. nuts (23.4).
  2. Move the Horizontal Bearing (23) laterally until it is in the required position.
  3. Align the tie rod (23.5). Ensure that the tie rod protrusion on the left and right is the same size.
  4. Tighten both hex. nuts (23.4a).
  5. Counter with the two hex. nuts (23.4b).
- (Fig. A4.02)

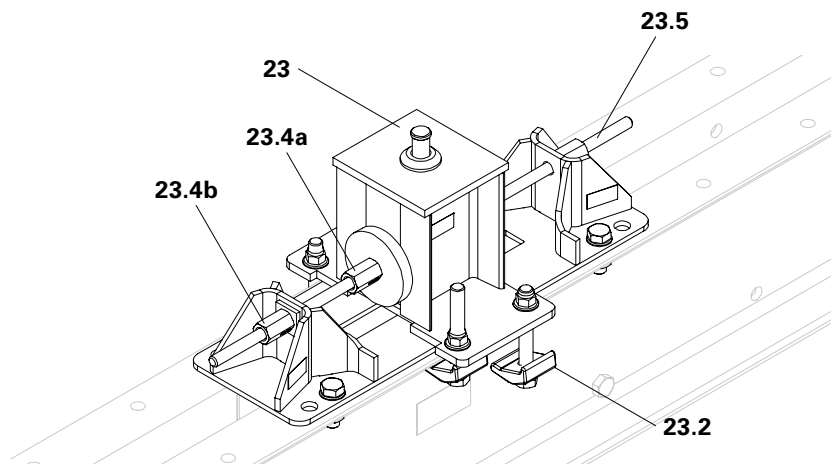

Fig. A4.02



- If a Cross Fall Bearing is required on the bearing in addition to the Longitudinal Bearing, see Section "Bearing with the Cross Fall Bearing" on Page 38.
- If a Cross Fall Bearing is not required on the bearing, see Section "Bearing without the Cross Fall Bearing" on Page 40.

## Bearing with the Cross Fall Bearing

### Components

- 23** Horizontal Bearing-2 VRB
- 24** Cross Fall Adapter VRB

### Installing the Cross Fall Adapter

The Cross Fall Adapter (24) is required if a Cross Fall Bearing is installed on the bearing in addition to the Longitudinal Bearing. The Cross Fall Adapter evens out the resulting height difference on the Horizontal Bearing (23).

### Assembly

1. Remove bolts (23.3) and clamps (23.2).
  2. Loosen both hex. nuts (23.4) and screw out tie rod (23.5).
  3. Lift the top part of the Horizontal Bearing (23).
  4. Slide the Cross Fall Adapter (24) in between and position it so that the holes align with the top part of the Horizontal Bearing.
- (Fig. A4.03)
5. Screw in the tie rod. Ensure that the tie rod protrusion on the left and right is the same size.
  6. Tighten the Horizontal Bearing (23) with the clamps (23.2) and bolts (23.3).
  7. Tighten nuts (23.4).
- (Fig. 4.04)

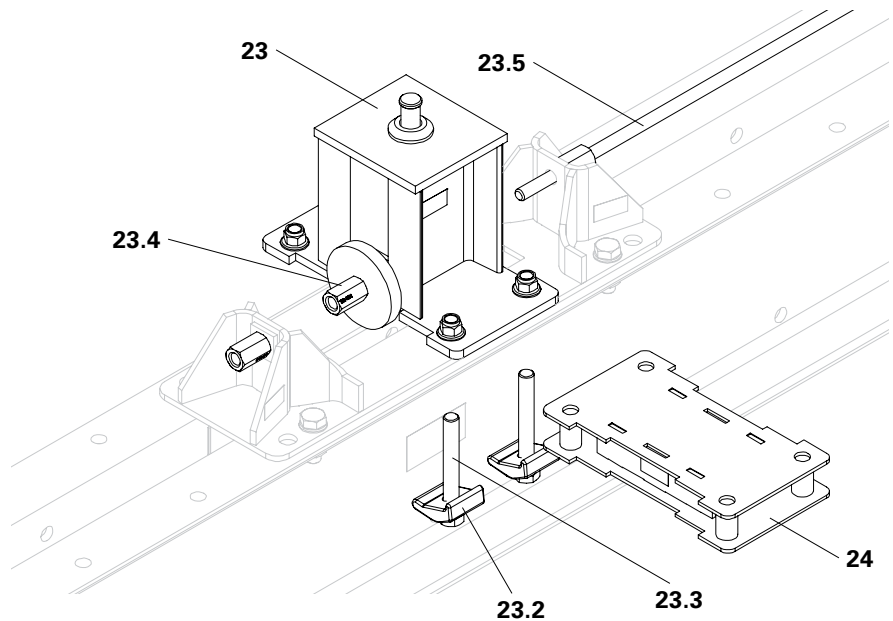

Fig. A4.03

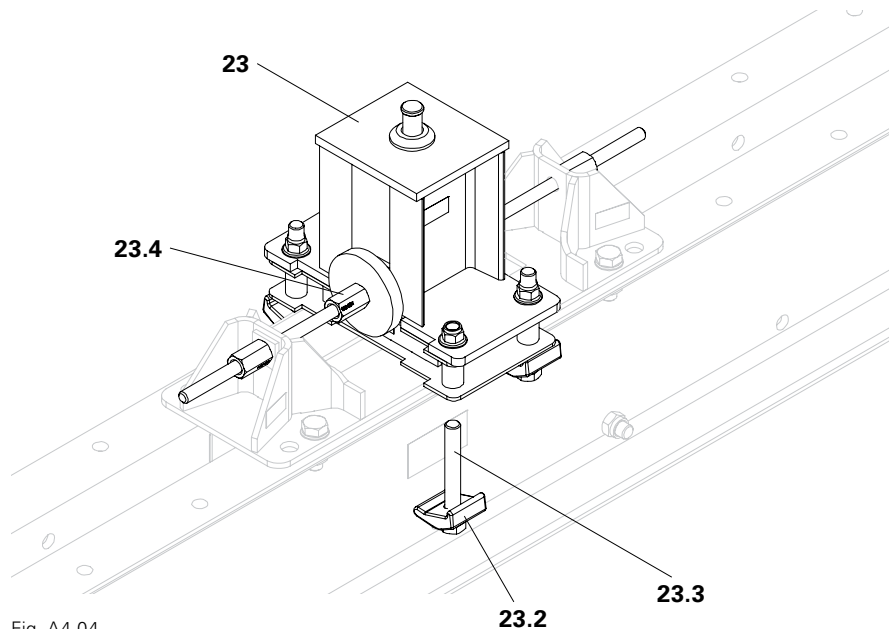

Fig. A4.04

# A4 Assembly of the Main Beam

## Components

- 20 Centering Plate HDT-VRB
- 21 Cross Fall Bearing VRB
- 22 Longitudinal Bearing VRB
- 35 Main Beam

## Installing the support for truss package 150 cm



For easier dismantling, apply lubricant under the Centering Plate (20).

## Assembly

1. Place the Centering Plate (20) on the Main Beam (35). The spacing to the Horizontal Bearing (23) is centre - centre 75 cm.
  2. Secure the Centering Plate with bolts (20.1).
  3. Place the Cross Fall Bearing (21) on the Centering Plate.
  4. Position the Longitudinal Bearing (22) on the Cross Fall Bearing.
- (Fig. A4.05)

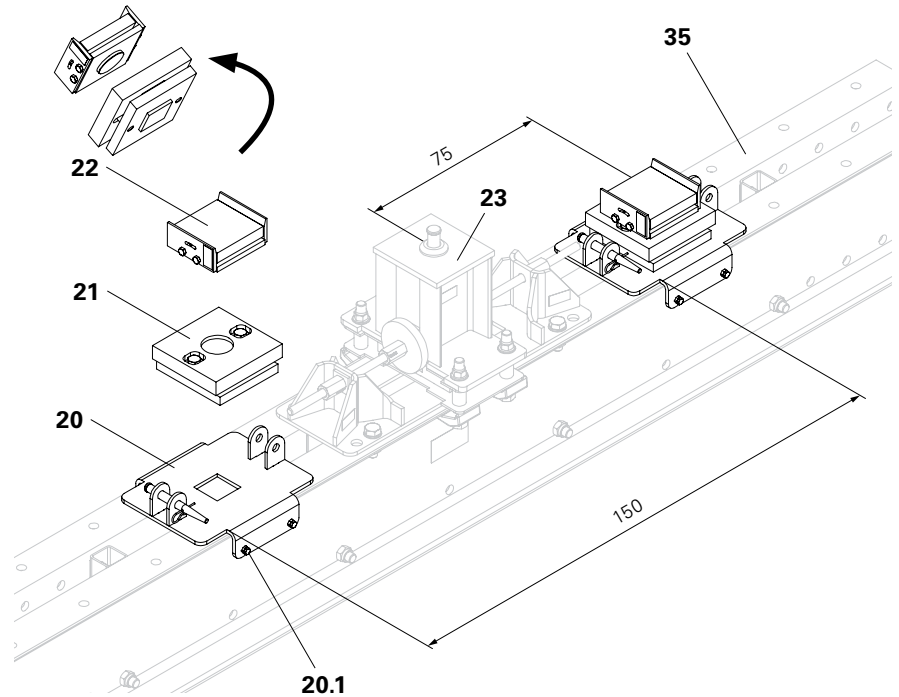

Fig. A4.05



- Is the square centering aid of the Cross Fall Bearing correctly positioned in the square recess of the Centering Plate?
- Is the circular centering aid of the Longitudinal Bearing correctly positioned in the circular recess of the Cross Fall Bearing?



The spacing of both supports is 150 cm (Fig. A4.05).

## Support without Cross Fall Bearing

### Components

- 20** Centering Plate HDT-VRB
- 22** Longitudinal Bearing VRB
- 35** Main Beam



For easier dismantling, apply lubricant under the Centering Plate (20).

### Assembly

1. Place the Centering Plate (20) on the Main Beam (35). The spacing to the Horizontal Bearing (23) is centre - centre 75 cm.
2. Secure the Centering Plate with bolts (20.1).
3. Place the Longitudinal Bearing (22) on the Centering Plate.  
(Fig. A4.06)

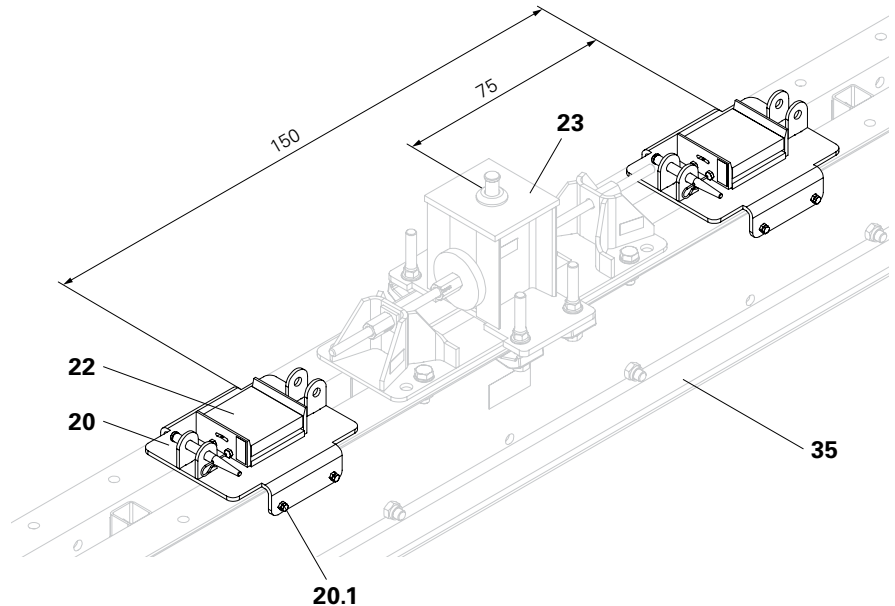

Fig. A4.06



Is the circular centering aid of the Longitudinal Bearing correctly positioned in the square recess of the Centering Plate?



The spacing of both supports is 150 cm (Fig. A4.06).

In the same way, accurately mount additional supports using the frame spacing dimensions of the truss package or single trusses on the Main Beam.

## Coupling the Main Beams

### Components

- 35** Main Beam
- 36** Main Beam Connector VRB
- 41** Cotter Pin 5/1
- 46** Fitting Pin  $\varnothing$  26 x 105 VRB

In order to extend the support area, several Main Beams can be coupled together.

### Assembly

1. Mount the Main Beam Coupling (36) to the Main Beam (35a) using 8 fitting pins (46) and secure with cotter pins (41).

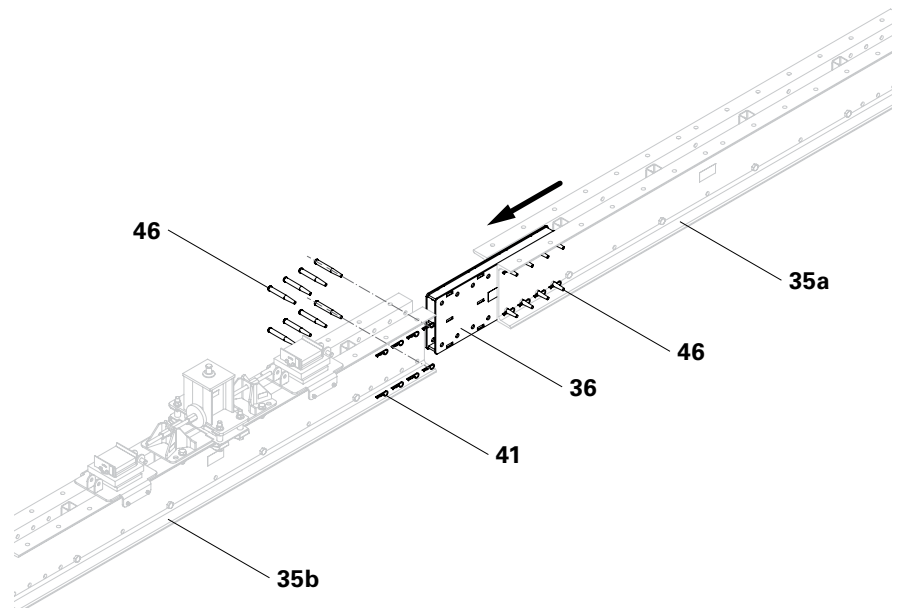

Fig. A4.07



### Warning

Risk of crushing through heavy moving parts!

Risk of hands being crushed when coupling the two Main Beams.

⇒ Do not take hold of anything between the components.

2. Push Main Beam (35b) together with Main Beam (35a).
  3. Connect both Main Beams using 8 fitting pins and secure with cotter pins.
- (Fig. A4.07)



Have all fitting pins been inserted and secured with cotter pins?



## Danger

Heavy moving parts can fall down or overturn!

During assembly, there is a risk of hands and other body parts being crushed.

- ⇒ Leave the area of risk on the Main Beams.
- ⇒ Do not stand under suspended loads.
- ⇒ Use a guide rope when moving components.
- ⇒ Maintain an appropriate safety distance.
- ⇒ Do not stand between moving elements.



Attach PPE!



Take into account project-specific attachment positions on the truss package.



If the two Main Beams are not of the same height, the height difference must be evened out when transporting by crane. The truss package must be placed on both Main Beams at the same time with dimension  $x$  corresponding to dimension  $y$ . (Fig. B1.01a + Fig. B1.01b)

Determine the inclination by trial and error when attaching to the crane lifting gear.

If the truss package is positioned too early on one side, horizontal forces are created which can move or overturn the Main Beam. (Fig. B1.01)

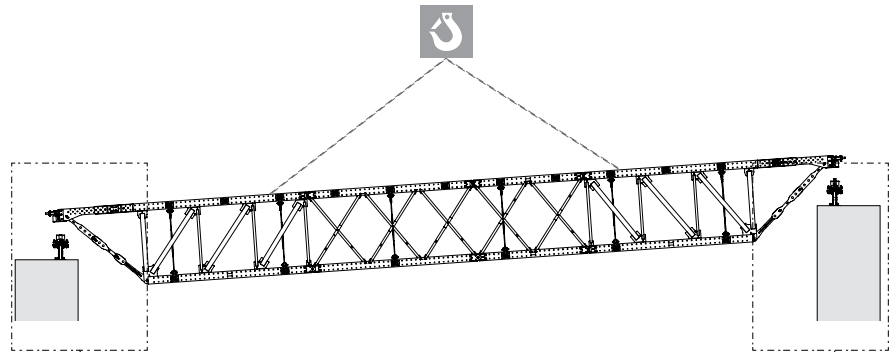

Fig. B1.01

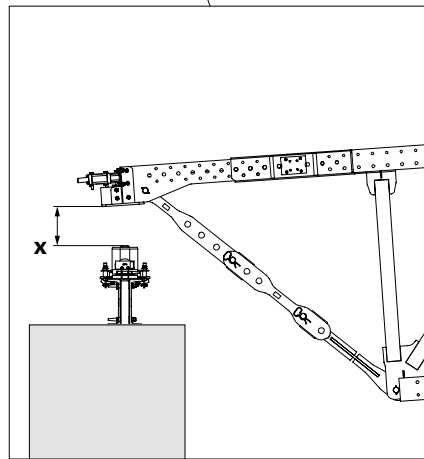

Fig. B1.01a

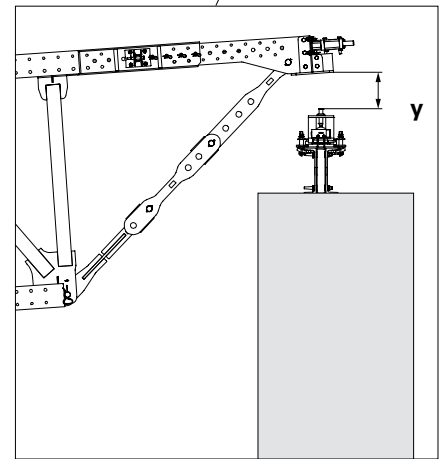

Fig. B1.01b



Before transporting the truss package (Fig. B1.02) by crane, the PERI UP Flex system must be mounted on the truss package. See Section "D1 Assembly of PERI UP Flex" on Page 52.



Attach PPE!

## Assembly

1. Remove cotter pins (23.7) and pull bolts out of the Horizontal Bearing (23).
  2. Attach truss package using suitable load-carrying means.
  3. Loosen the connection between the truss package and assembly aids (Climbing Rails). For this, remove cotter pins and pull out fitting pins.
  4. Crane in the truss package and position above the Main Beams (35).
  5. Slowly lower the truss package and place the Bearing Frames (2) on the Longitudinal Bearings (22).
  6. Insert the bolt (23.6) through the designated hole on one side of the truss package and connect the Bracing Traverse (30) to the Horizontal Bearing (23).
  7. Secure bolts (23.6) with cotter pins (23.7).
- (Fig. B1.03)
8. Repeat Steps 5 to 7 on the other side of the truss package.

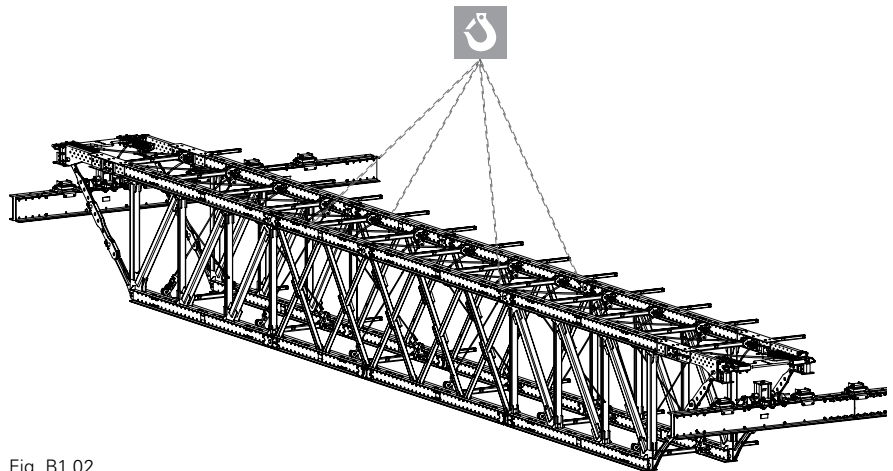

Fig. B1.02

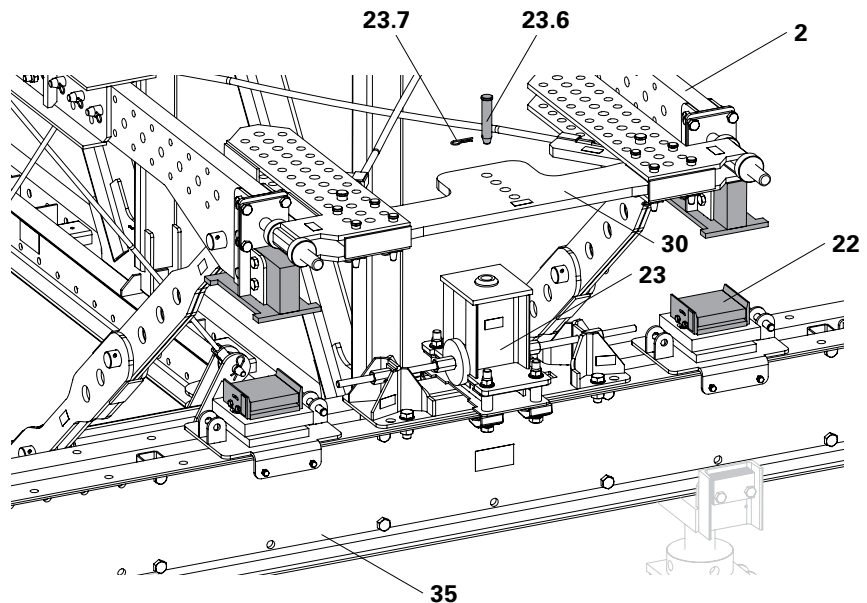

Fig. B1.03



If the holes in the Bracing Traverse (30) and Horizontal Bearing (23) are not aligned, the position of the Bracing Traverse must be adjusted. (Fig. B1.04)

### Adjusting the Bracing Traverse

1. Loosen tie rod (10) on the Articulated Spanner (9).
2. Loosen nuts (32.1).
3. Adjust the Bracing Traverse (30) so that one of the holes is aligned with the hole in the Horizontal Bearing (23).
4. Insert the bolt (23.6) through the designated hole and connect the Bracing Traverse to the Horizontal Bearing (23).
5. Secure bolts (23.6) with cotter pins (23.7).
6. Tighten nuts (32.1).
7. Adjust the tie rod (10) on the Articulated Spanner (9) so that it is free of any play.

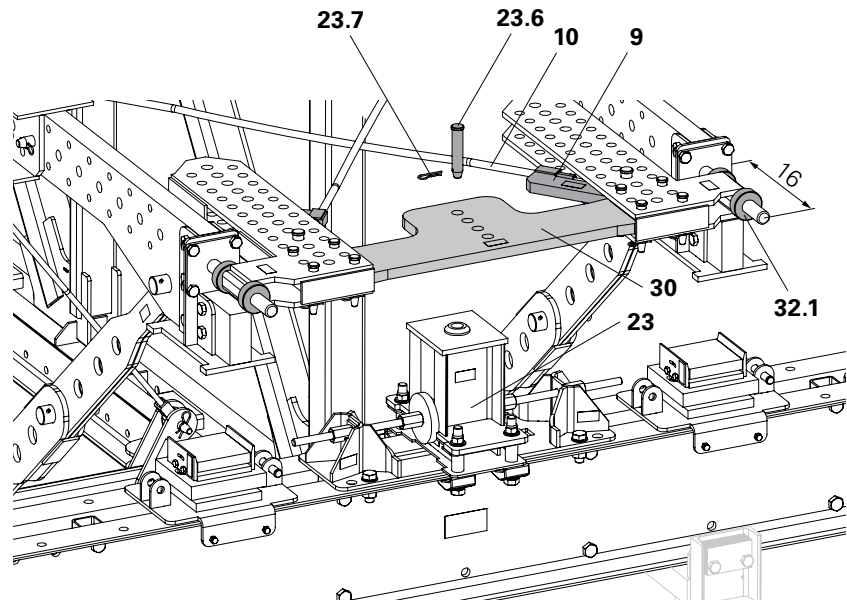

Fig. B1.04



- The Bearing Frame has a 29-cm-long recess. This allows longitudinal adjustment of the truss package by up to 13 cm. (Fig. B1.05 + Fig. B1.06)
- If the Horizontal Bearing (23) has to be laterally moved to achieve the exact position, see "Aligning the Horizontal Bearing" on Page 37.

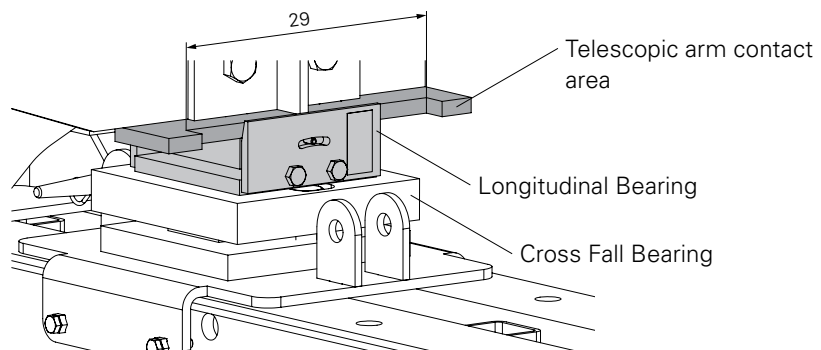

Fig. B1.05



Does the Bearing Frame completely lie in the Longitudinal Bearing? (Fig. B1.06)

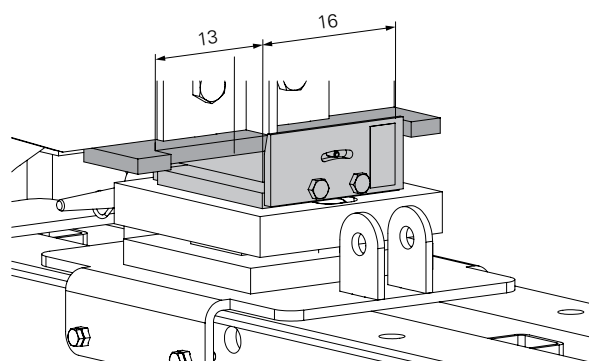

Fig. B1.06



## Danger

Heavy moving parts can fall down or overturn!

During assembly, there is a risk of hands and other body parts being crushed.

- ⇒ Leave the area of risk on the Main Beams.
- ⇒ Do not stand under suspended loads.
- ⇒ Use a guide rope when moving components.
- ⇒ Maintain an appropriate safety distance.
- ⇒ Do not stand between moving elements.



Attach PPE!



Take into account project-specific attachment positions on the single truss.

## Assembly

1. Attach single truss using suitable load-carrying means.
2. Raise the crane lifting gear until it is tensioned.
3. Loosen the connection between the single truss and assembly aids (Climbing Rail). For this, remove cotter pins and pull out fitting pins.
4. Crane in the single truss and position above the Main Beams (35). (Fig. B2.01)
5. Slowly lower the single truss and place the Bearing Frames (2) on the Longitudinal Bearings (22). (Fig. B2.02)



Does the Bearing Frame completely lie in the Longitudinal Bearing?  
(Fig. B1.06)

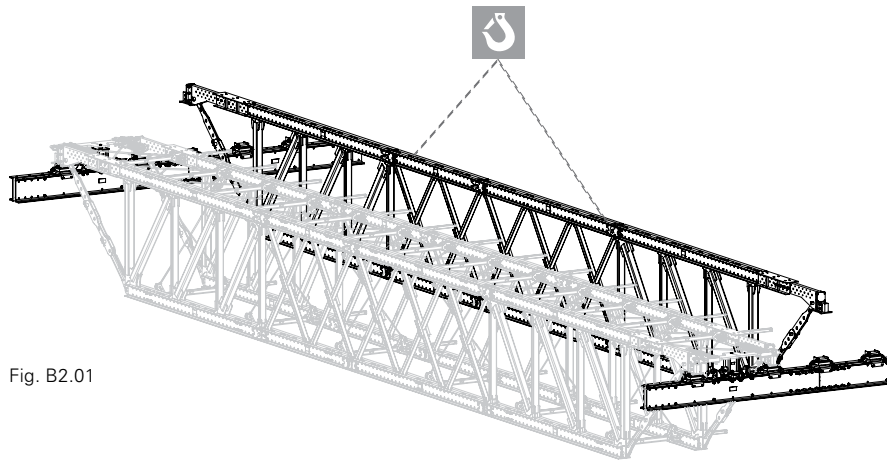

Fig. B2.01

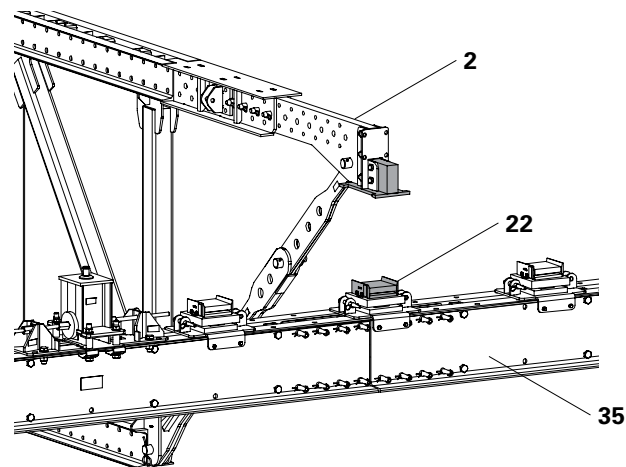

Fig. B2.02



- The Coupling Posts (7) have already been mounted on the truss package.
  - The Coupling Shoes (5) have already been mounted on the single truss.
- See Section "Coupling with a Single Truss" on Page 34.



Attach PPE!

## Assembly

1. Fold Coupling Posts (7) upwards. (Fig. B3.01)
2. Connect all Coupling Posts (7) in the top and bottom chords to the Coupling Shoe (5).
3. Insert fitting pins (43) and secure with cotter pins (40).



- Have all Coupling Posts been mounted?
- Have all fitting pins been inserted and secured with cotter pins?

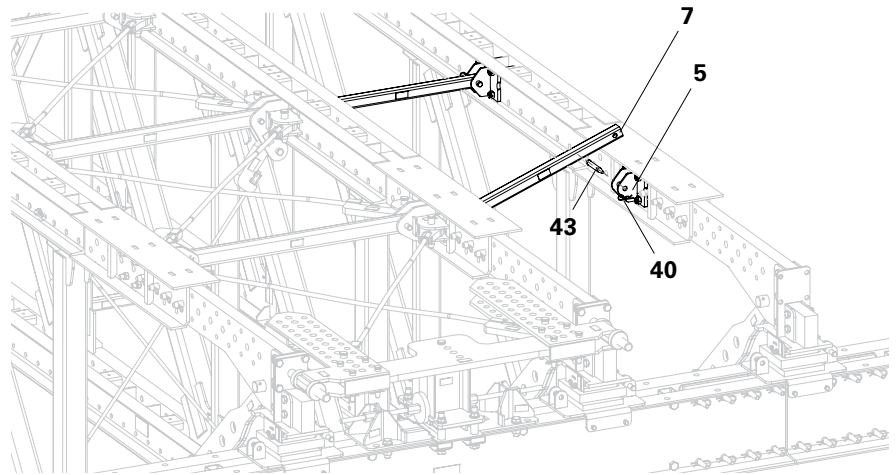

Fig. B3.01

## Notes

The Longitudinal Bearing evens out any height difference between the supports. This is possible up to an angle of  $4^\circ$ . (Fig. C1.01)



The longitudinal inclination between the supports may not exceed an angle of  $4^\circ$  which corresponds to a gradient of 7 %.

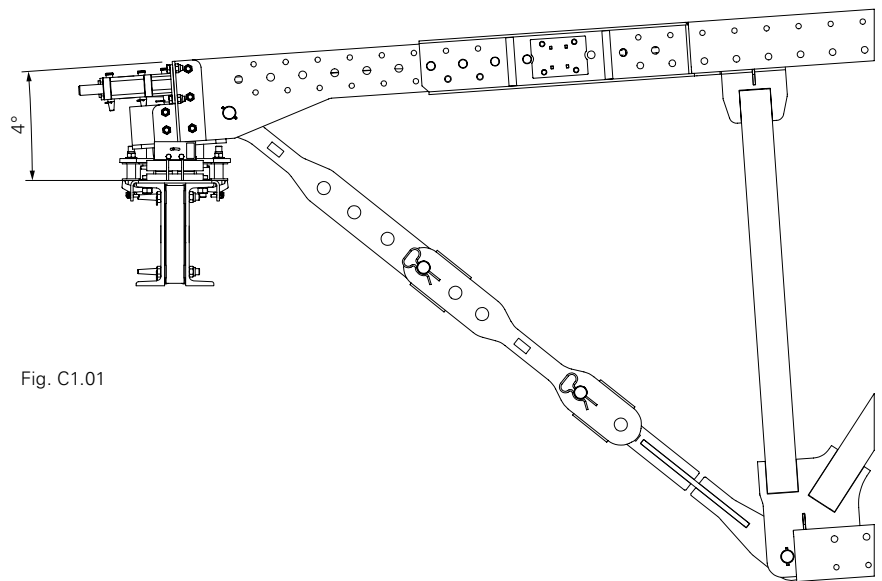

Fig. C1.01

The Cross Fall Bearing evens out an inclination of the Main Beam. This is possible up to an angle of 4°.

The frame remains in a vertical position in spite of the lateral inclination.



The lateral inclination of the Main Beam may not exceed an angle of 4°. This corresponds to a gradient of 7 %.



- The tie rods of the horizontal and vertical bracing must have correspondingly adapted lengths for accommodating lateral inclinations.
- The tie rod projection on the nut must be at least 10 mm.



The truss package must be vertically aligned when placed on the Main Beam. For this, the tie rods (10) and (13) of the horizontal and vertical bracing must have sufficient play.

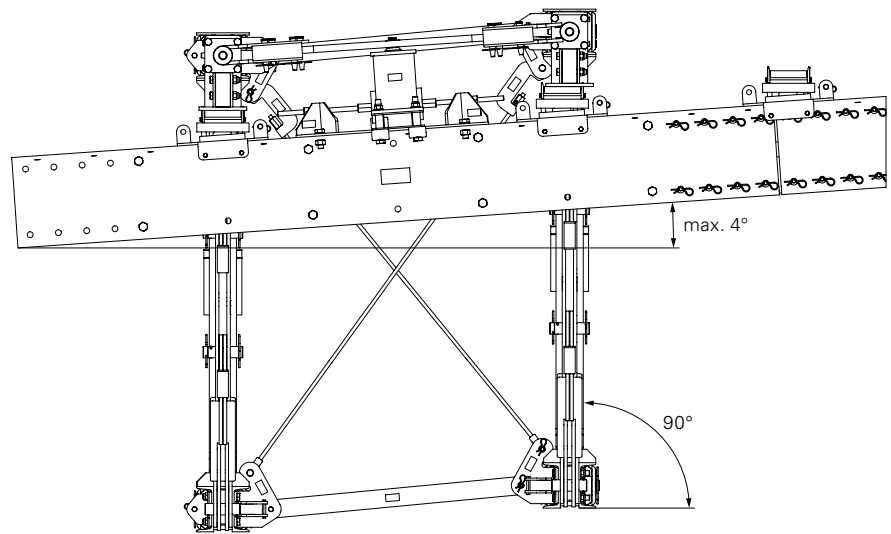

Fig. C2.01

### Assembly

1. Loosen all nuts (61) of the horizontal bracing on the Articulated Spanner (9).
2. Loosen all nuts (60) of the vertical bracing on the Articulated Spanner (12).
3. Crane in the truss package and position on the Main Beam.
4. Adjust all tie rods (10) of the horizontal bracing using the nuts (61) on the Articulated Spanner (9) so they are free of play.
5. Adjust all tie rods (10) of the vertical bracing using the nuts (60) on the Articulated Spanner (12) so they are free of play.

(Fig. C2.02)

See "Mounting the Horizontal Bracing" on Page 29 and "Mounting the Vertical Bracing" on Page 32.

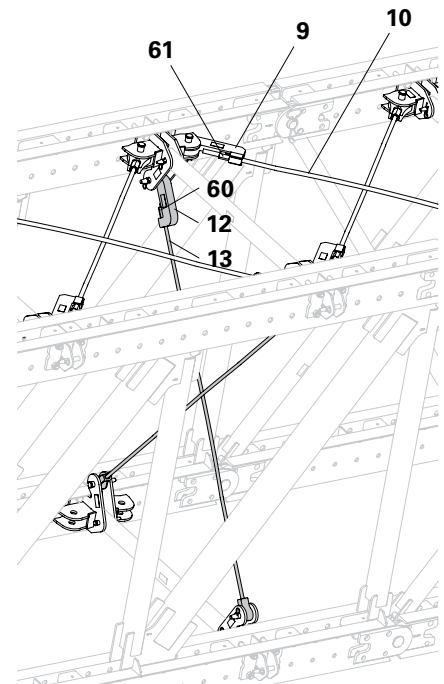

Fig. C2.02

Depending on the project, the support angle between the truss package and the Main Beam is not always 90°. In these cases, the crossing angle between the truss package and Main Beam can be continuously adjusted between 63.4° and 90°.



- The following working steps describe in general which activities have to be carried out.
- Fig. C3.01 and C3.02 serve as examples.
- The exact assembly position of some components can differ from the illustration due to specific project requirements.
- Details provided in the assembly drawings are binding.

## Crossing Angle from 67.4° to 90°

### Assembly

1. Extend the Bearing Frame (2). (Fig. C3.01)
2. Mount the Bracing Traverse (30).
3. Adjust the Bracing Traverse with the help of the bracing spindles (32). One of the four holes must be centered on the connecting line of the two bracing spindles. Here in the example: Hole No. 2 (Fig. C3.01a)
4. Mount the Articulated Spanner (9). For this, insert the bolts (47) into the first possible hole and secure with a cotter pin.
5. Adjust the tie rod (10) so that it is free of any play.



- ⇒ The four fitting pins (47) must be mounted in the four outer holes of the telescopic arm guide (2.5).
- ⇒ Also when fully extended, all four fitting pins (47) must be securely mounted. See "Adjusting the Bearing Frame" on Page 21.
- ⇒ The telescopic arm (2.4) must always be fixed with all four fitting pins (47).
- ⇒ The Bracing Traverse (30) must always be mounted with all bolts (45) on the Bracing Frame connection (31).

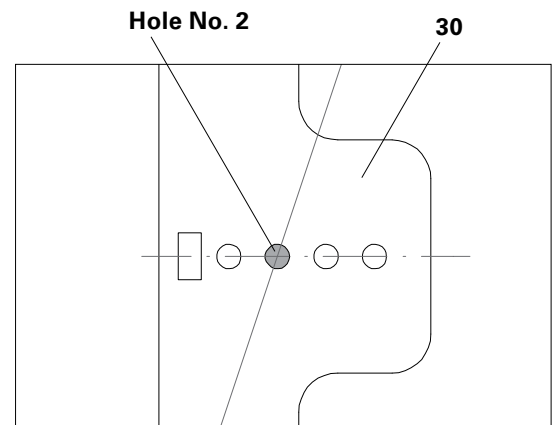

Fig. C3.01a

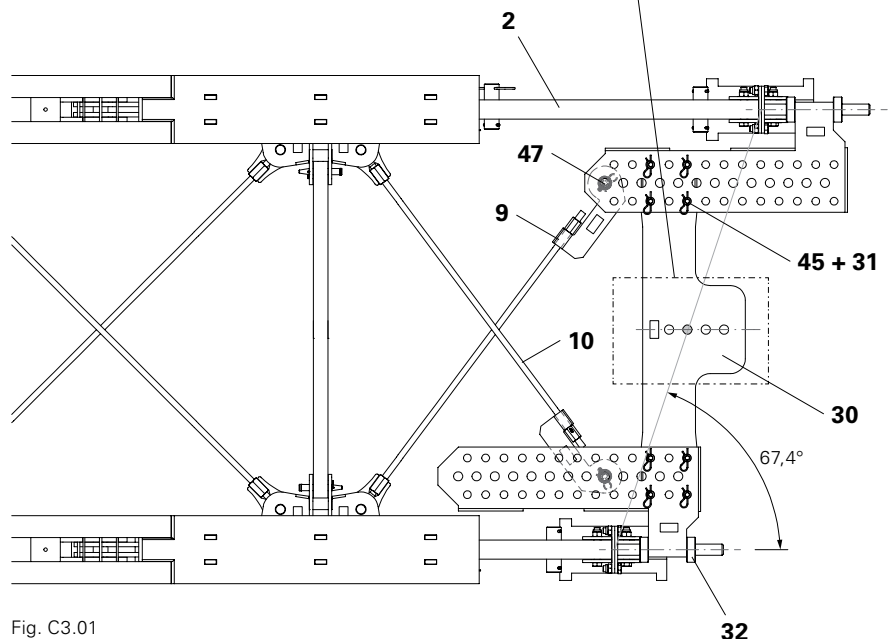

Fig. C3.01

## Crossing Angle from 63.4° to 67.4°

Here, the Bracing Traverse connector is turned on the shorter side of the Telescopic Box. This is necessary in order to be able to connect the Bracing Traverse.

### Assembly

1. Extend the Bearing Frame (2).  
(Fig. C3.02)
2. Mount the Bracing Traverse (30).
3. Adjust the Bracing Traverse (30) with the help of the bracing spindles (32).  
One of the four holes must be centered on the connecting line of the two bracing spindles. Here in the example: Hole No. 3 (Fig. C3.02a)
4. Mount the Articulated Spanner (9).  
For this, insert the bolts (47) into the first possible hole and secure with a cotter pin.
5. Adjust the tie rod (10) so that it is free of any play.



If additional single trusses are connected for strong crossing angles, project-specific alternative solutions are required.

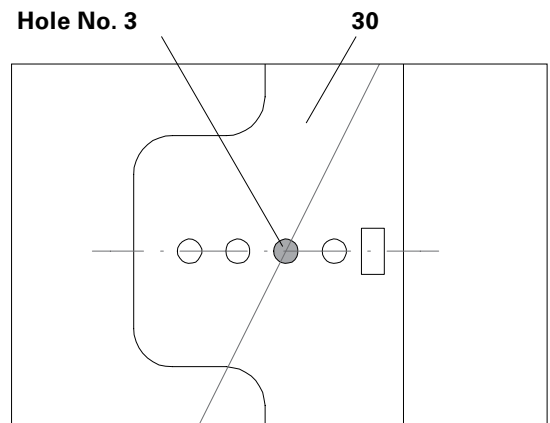

Fig. C3.02a

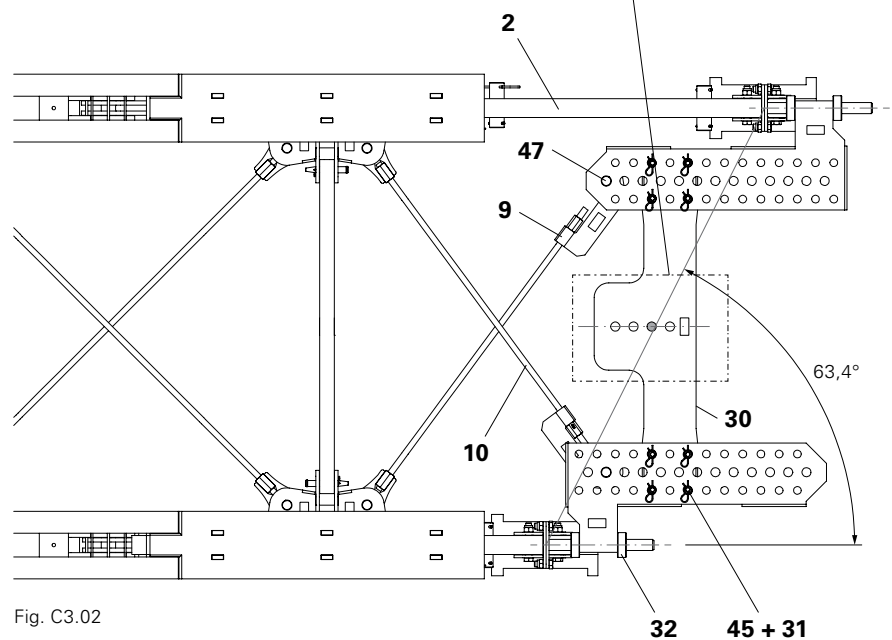

Fig. C3.02

## Connection Assembly

### Components

- 41** Cotter Pin 5/1
- 46** Fitting Pin  $\varnothing$  26 x 120
- 80** Connector UP-VRB



- This step is carried out together with the assembly of the bracing connections. See "Mounting the Bracing Connections" on Page 24.
- The assembly of Connector UP-VRB takes place on the inner side of the truss package.

### Assembly

1. At a distance of 115.8 cm, insert the Connector UP-VRB (80) between the two guardrails of the bottom chord. (Fig. D1.01)
2. Fit bolts (46) and secure with cotter pins (41).
3. Fit additional Connectors (80) at a distance of 300 cm. (Fig. D1.02)



Depending on the project, the distances can be changed especially in the area of the supports.

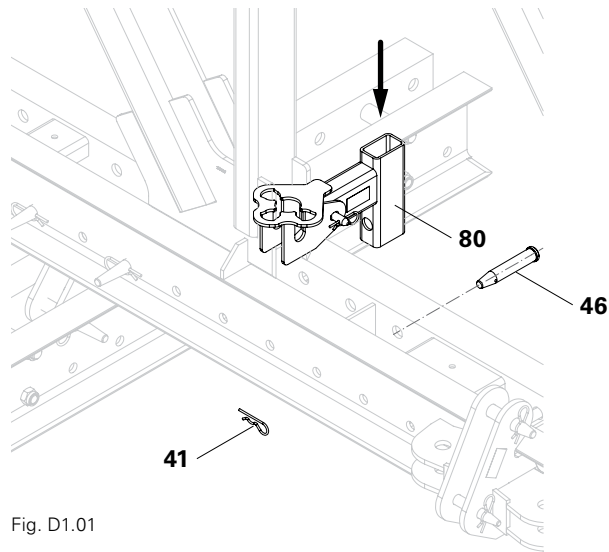

Fig. D1.01

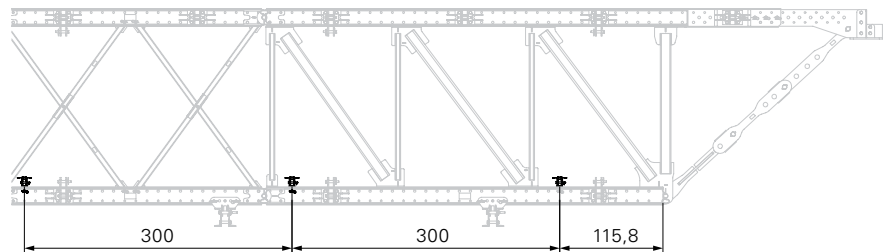

Fig. D1.02

## Assembly in the Truss Package

### Components

- 90** Top Standard UVH 150
- 92** Ledger UH 100 Plus
- 93** Ledger UH 300 Plus
- 94** Steel Deck UDG 25 x 300



This step is carried out after the horizontal and vertical bracing has been installed. See "Mounting the Horizontal Bracing" on Page 29 and "Mounting the Vertical Bracing" on Page 32.



- The permissible live load is 75 kg/m<sup>2</sup>.
- Firmly secure the wedge of the ledger by means of a 500-g hammer.
- Lock the steel decking using the integrated protection against lifting.

### Assembly

1. Insert the Top Standard (90) with the long tube protrusion into the Connector (80). Ensure that the rosettes are flush with each other.
2. Hook the ledger (93) into the lower rosettes on both sides. The ledger (93) is positioned parallel to the truss package.  
(Fig. D1.04)

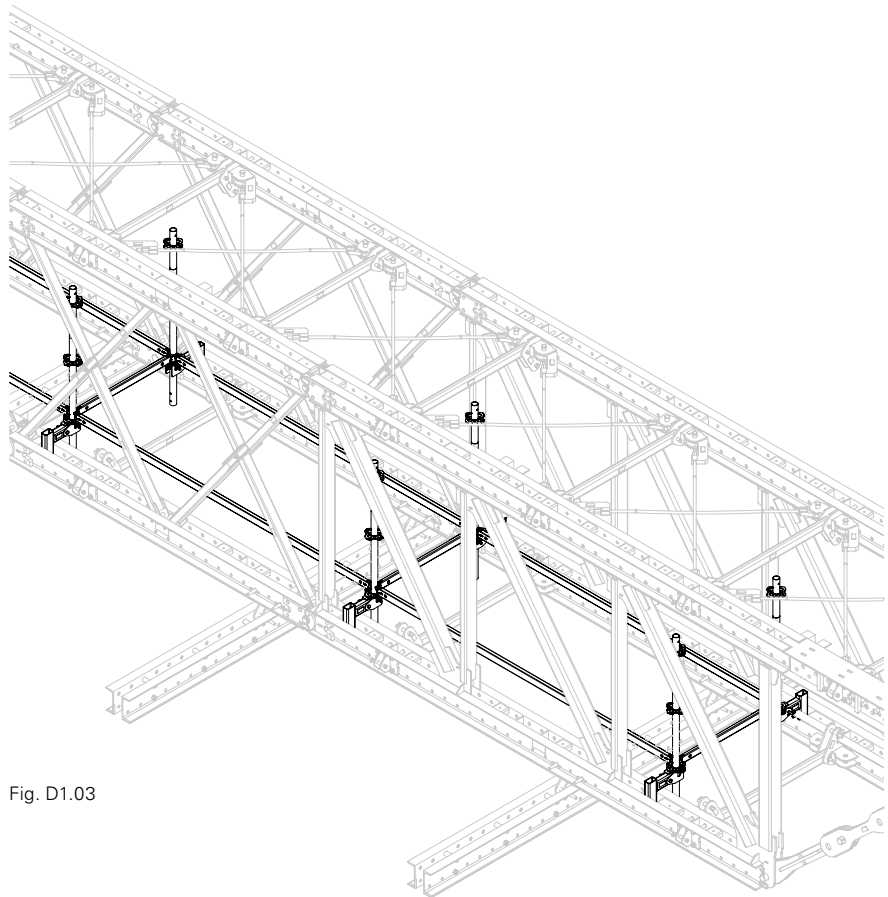

Fig. D1.03

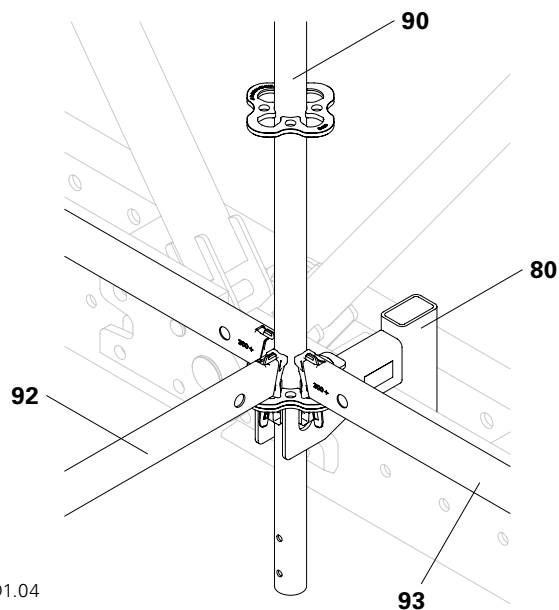

Fig. D1.04

3. Hook the ledger (92) into the rosettes on both sides. The ledger (92) is positioned vertically to the truss package.
  4. Place four Steel Decks (94) in the field.
  5. Hook additional ledgers (92) and (93) into the rosettes of the Top Standards as guardrails.
- (Fig. D1.05)



- Are all wedges of the ledgers securely in place?
- Are all steel decks locked in position with the integrated protection against lifting?
- Are all the clamps of the steel decking flush with the decks when closed?

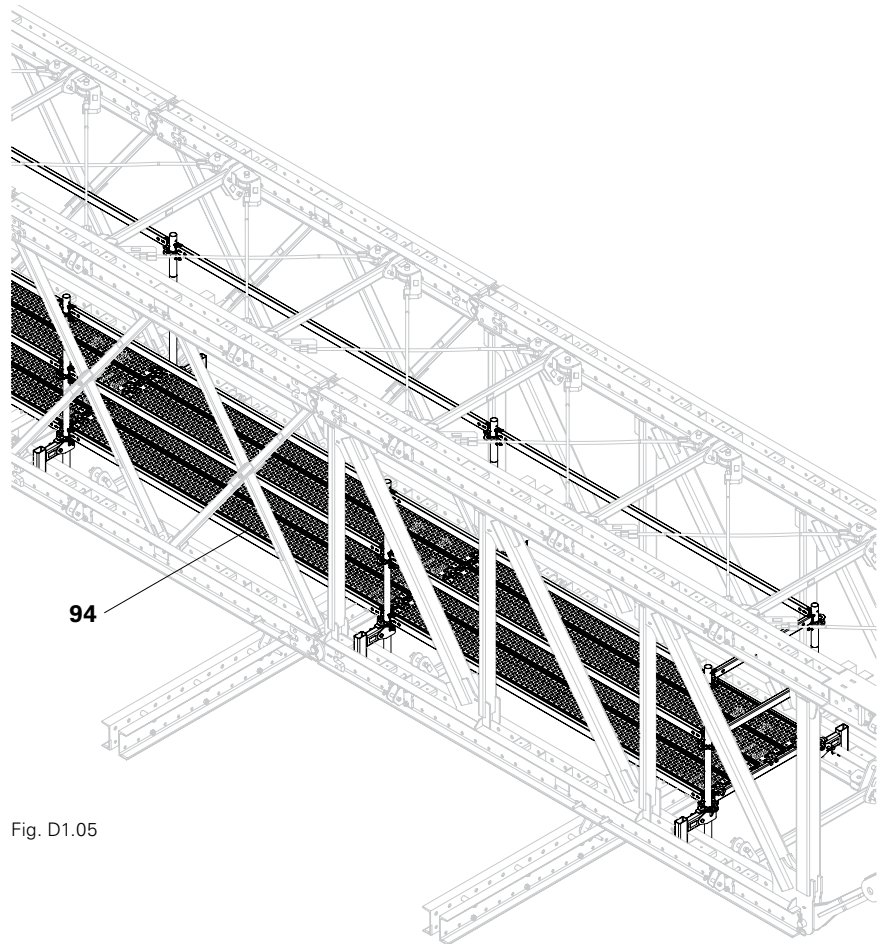

Fig. D1.05

## Assembly of Bracket Connection

### Components

- 41** Cotter Pin 5/1
- 46** Fitting Pin  $\varnothing$  26 x 105 VRB
- 81** Bracket Connector UP-VRB



- This step is carried out together with the assembly of the bracing connections. See "Mounting the Bracing Connections" on Page 24.
- Assembly of the Bracket Connector UP-VRB takes place on the outer side of the truss package.

### Assembly

1. At a distance of 40.8 cm, insert the Bracket Connector UP-VRB (81) between the two guardrails of the bottom chord.
2. Fit bolts (46) and secure with cotter pins (41). (Fig. D1.06)
3. Mount additional Bracket Connectors (80) at a distance of 300 cm. (Fig. D1.07)



Depending on the project, the distances can be changed especially in the area of the supports.

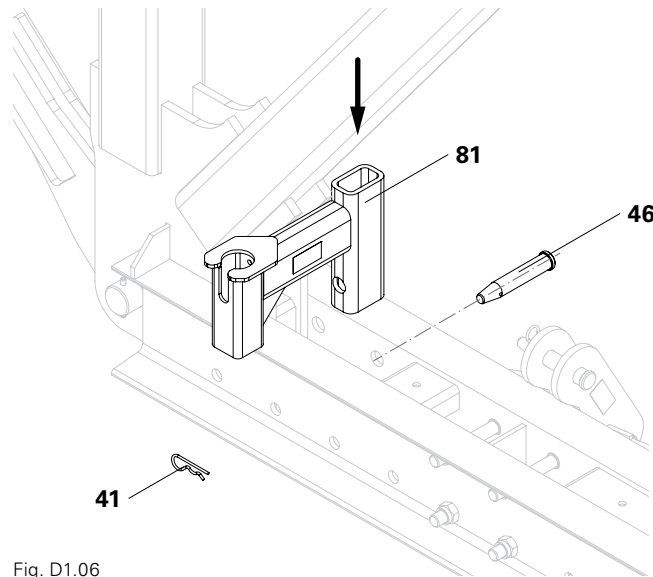

Fig. D1.06

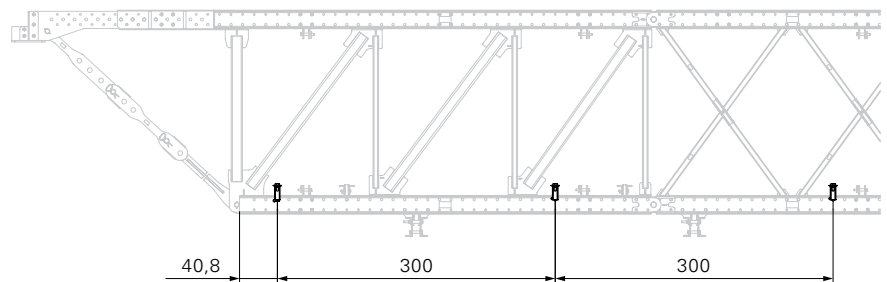

Fig. D1.07

## Assembly of Bracket on the Truss Package

### Components

- 90** Top Standard UVH 150
- 91** Ledger UH 75 Plus
- 93** Ledger UH 300 Plus
- 94** Steel Deck UDG 25 x 300
- 95** Top Standard UVH 100
- 96** Console Bracket UCM 75 with Spigot



This step is carried out after the horizontal and vertical bracing has been installed. See "Mounting the Horizontal Bracing" on Page 29 and "Mounting the Vertical Bracing" on Page 32.



- The permissible live load is 75 kg/m<sup>2</sup>.
- Firmly secure the wedge of the ledger by means of a 500-g hammer.
- Lock the steel decking using the integrated protection against lifting.

### Assembly

1. Insert the Top Standard (90) with the long tube protrusion into the Bracket Connector (80).
2. Attach Console Bracket (96) to the rosette. The Console Bracket is positioned vertically to the truss package.
3. Attach the Top Standard (95) to the Console Bracket.(Fig. D1.08)
4. Hook the ledger (93) into the lower rosettes on both sides. The ledger is positioned parallel to the truss package. (Fig. D1.09)

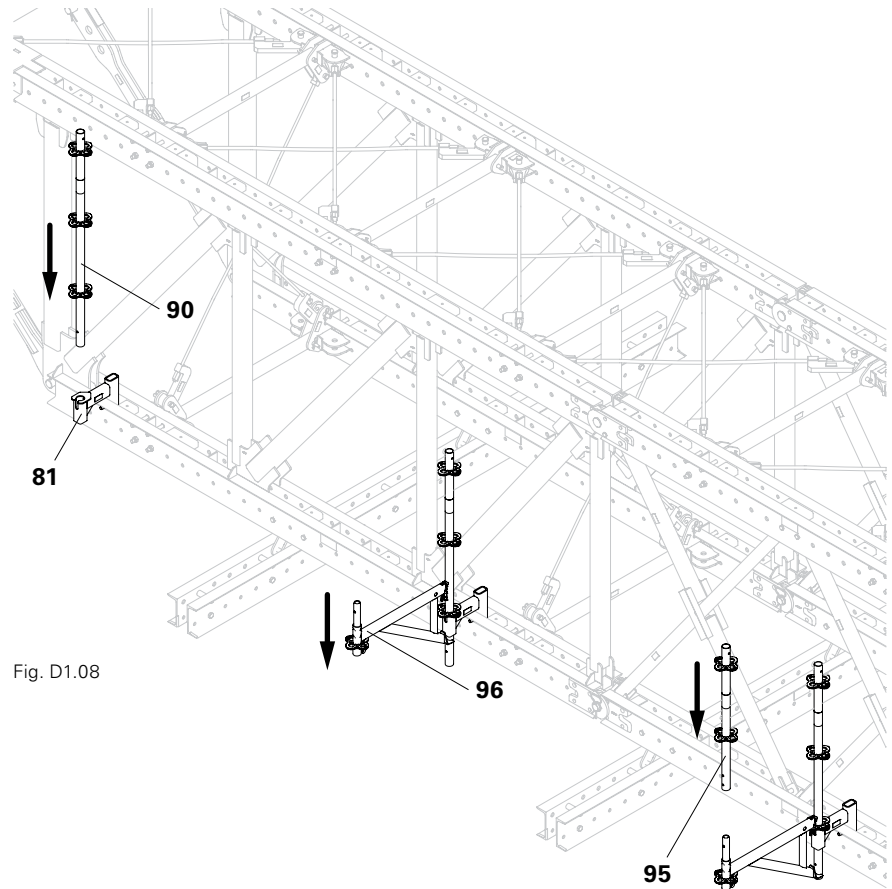

Fig. D1.08

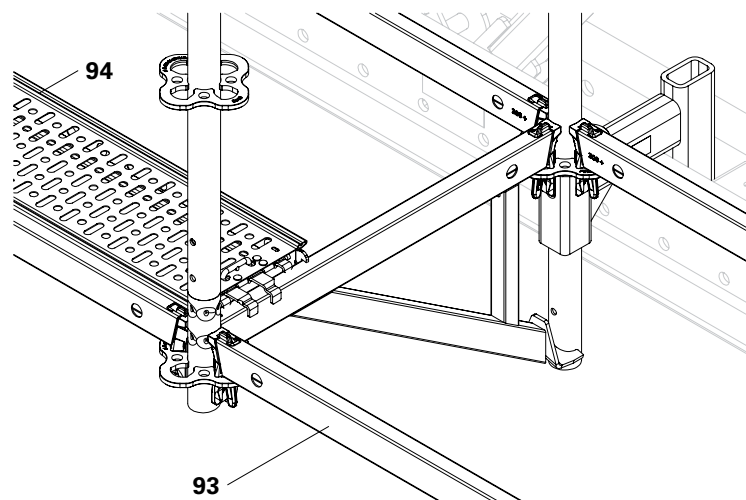

Fig. D1.09

5. Place three Steel Decks (94) in the field.
  6. Hook additional ledgers (91) and (93) into the rosettes of the Top Standards (90) and (95) as guardrails on the outer sides.
- (Fig. D1.10)



- Are all wedges of the ledgers securely in place?
- Are all steel decks locked in position with the integrated protection against lifting?
- Are all the clamps of the steel decking flush with the decks when closed?

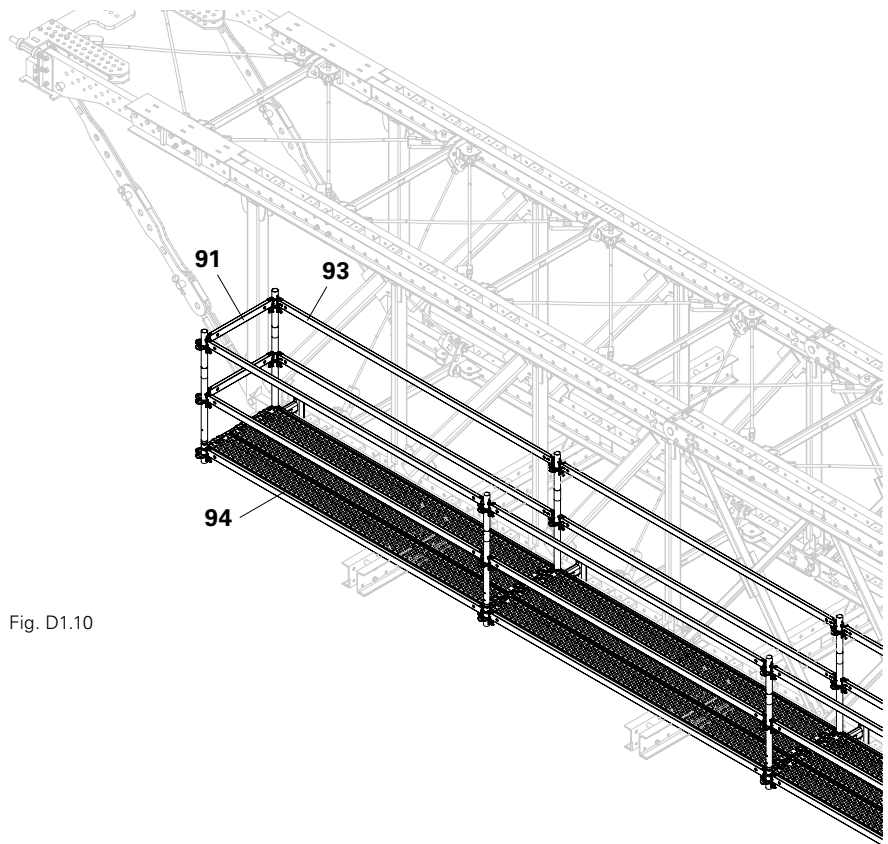

Fig. D1.10



- A project-specific dismantling plan complete with all intermediate states is required! The dismantling plan is binding and must be followed at all times.
- Dismantling the Heavy-Duty Truss Girder takes place only after the project manager has given the go ahead.



Attach PPE!

## Dismantling single trusses

1. Lower the Main Beams (35), including the truss girder and formwork, onto the supports.
2. Remove the entire formwork assembly.
3. Loosen the connection of the Coupling Posts to the single truss.
4. Attach the lifting chain with the bolt (44) to the centering plate (20) and secure with cotter pin. Repeat procedure at the other end of the single truss.

(Fig. E1.01 + E1.01a)



Apply lubricant to the Main Beam. This makes it easier to remove the truss package and single trusses.

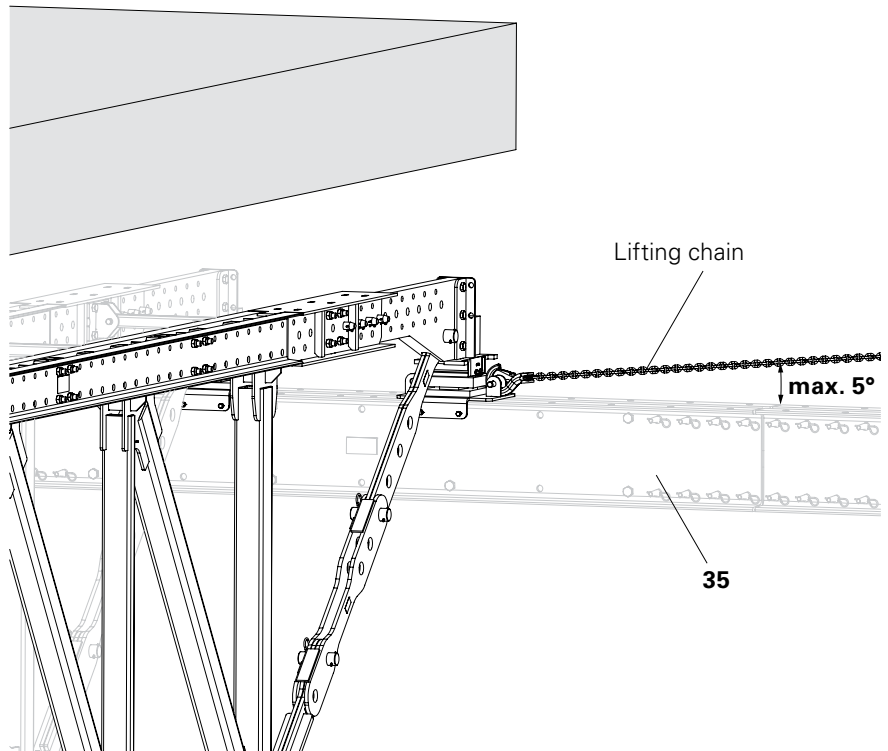

Fig. E1.01

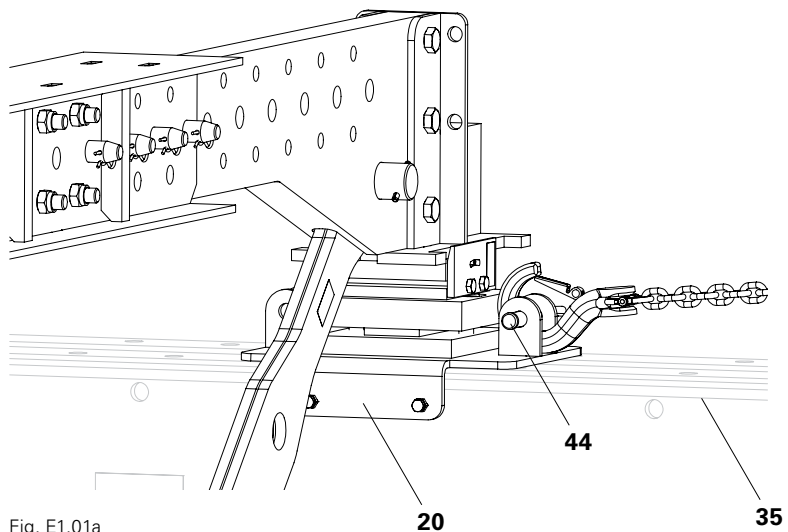

Fig. E1.01a

 **Danger**

Single truss could slide off the Main Beam!

Serious injury or death due to components falling to the ground.

⇒ Pull single trusses outwards on both sides evenly and smoothly.

⇒ Leave the area of risk under the single truss.

5. Pull single truss outwards along the Main Beam until the single truss is completely removed. The single truss is guided on the Main Beam through the centering plate.

6. Attach single truss to the crane lifting gear and crane out. For this, select suitable load-bearing points on the single truss.

(Fig. E1.02)

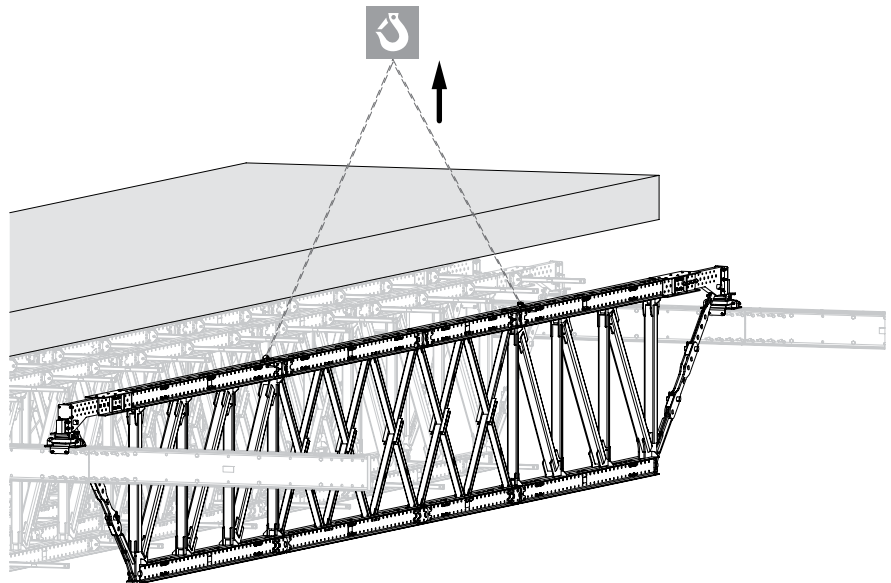

Fig. E1.02

Dismantling the truss package takes place in the same way. Firstly, the Horizontal Bearing must be removed.

## Removing the Horizontal Bearing

1. Remove cotter pins and pull out bolts (23.6).
  2. Remove clamps (23.2).
  3. Remove bolts (23.1).
  4. Remove Horizontal Bearing (23) from the Main Beam (35).
- (Fig. E1.03)

## Dismantling the girder package

1. Lower the Main Beam (35), including the truss girder and formwork, onto the supports.
  2. Remove the entire formwork assembly.
  3. If fitted, release the Coupling Post or bracing connections to the adjacent single trusses or truss package.
  4. Attach the lifting chain to the centering plate (20) with the bolt (44) and secure with cotter pin. Repeat procedure at the other end of the truss package.
- (Fig. E1.01a)

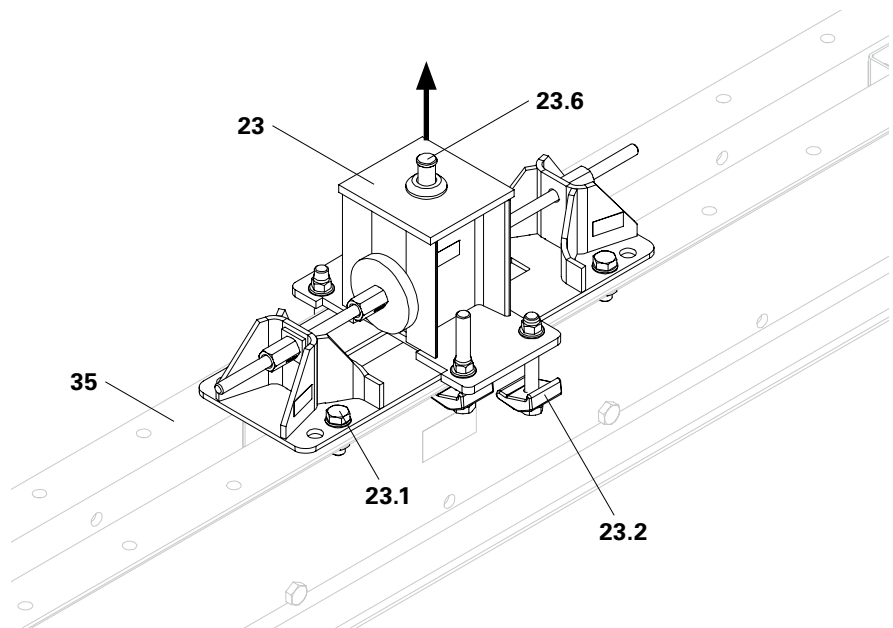

Fig. E1.03



## Danger

Truss package could slide off the Main Beam!

Serious injury or death due to components falling to the ground.

- ⇒ Pull truss package outwards on both sides evenly and smoothly.
- ⇒ Leave the area of risk under the truss package.

5. Pull truss package outwards along the Main Beam (35) until the truss package is completely removed. The truss package is guided on the Main Beam through the centering plate.
6. Attach truss package to the crane lifting gear and crane out. For this, select suitable load-bearing points on the truss package.

## Dismantling Single Trusses



- Position timbers on the dismantling area. Ensure that each frame element is supported by two timbers.
- Lay the single truss flat on the timbers.
- Ensure that the connecting bolts (49) of the frames can be knocked out in a downwards direction.

### Dismantling the Bearing Frame

If necessary, retract the Telescopic Box. (Fig. E2.01 + E2.02)

### Dismantling

1. Unscrew the Coupling Shoes (5) in the top and bottom chords.
2. Remove the connecting bolts (49) from the adjacent frame element. (Fig. E2.03 + E2.04)
3. Attach the frames to the fitting pins in the top chord or with lifting straps to the crane.
4. Crane out frame and stack ready for transportation.

Repeat Steps 2 - 4 for all additional frame elements of the single truss.

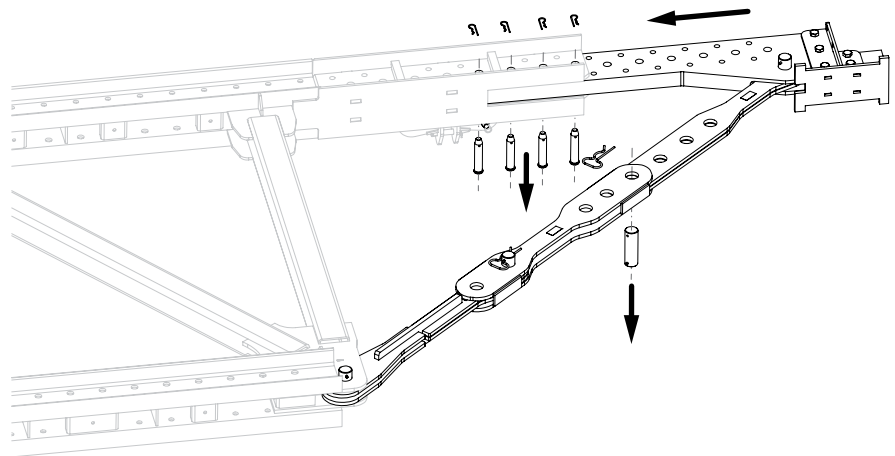

Fig. E2.01

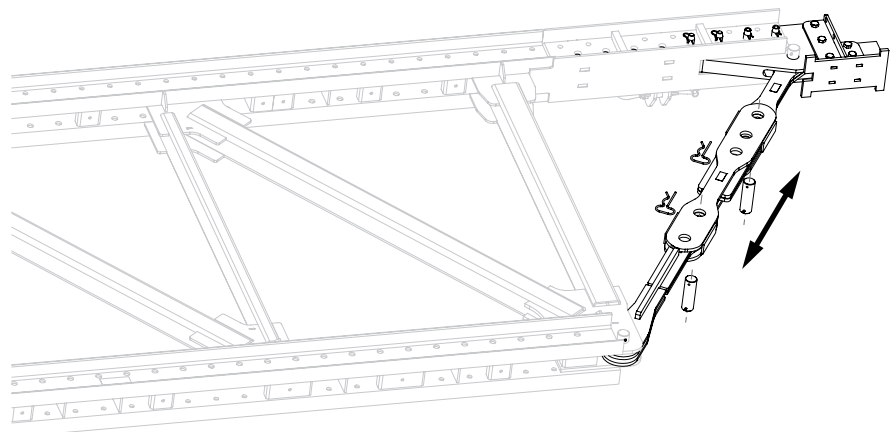

Fig. E2.02

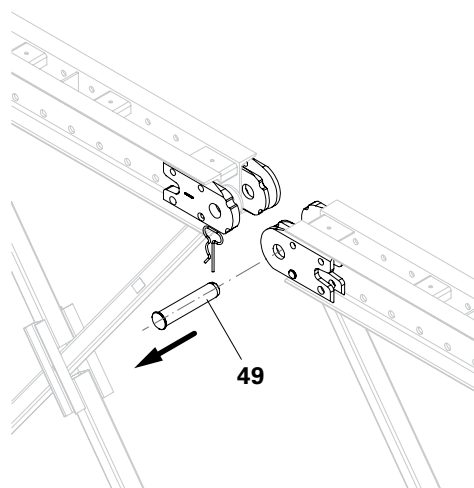

Fig. E2.03

## Dismantling the Truss Package



- Position Climbing Rails (70) on the dismantling area. Ensure that each frame element is supported by at least one Climbing Rail. (Fig. E2.04)
- The last frame element on each side must be supported by two Climbing Rails.
- Mount the Cross Connector (71) at a distance of 92.75 cm from the edge of the Climbing Rail.
- At the distance of the Bracing Posts (6), mount additional Cross Connectors on the Climbing Rails.
- Place the truss package on the Climbing Rails and fix it to the Cross Connectors.

### Dismantling the Bearing Frame

If necessary, retract the Telescopic Box before carrying out Steps 1 - 9. (Fig. E2.01 and E2.02)

### Dismantling

1. If fitted, dismantle Bracing Posts or Coupling Shoes which are connected to the adjacent package.
2. Remove vertical and horizontal bracing.
3. Attach Bracing Traverse to the crane lifting gear, dismantle and then crane out.
4. Dismantle Bracing Posts (6).
5. Unscrew Bracing Shoes (3), Vertical Bracing Shoes (4) and Coupling Shoes (5).
6. Attach the frames to the fitting pins in the top chord or with lifting straps to the crane.
7. Knock out fitting pins from the Cross Connector.
8. Remove the connecting bolts (49) from the adjacent frame element. (Fig. E2.03)



### Warning

Be aware of heavy moving components that can overturn or move in an uncontrolled way!

This could result in serious contusions or injury.

⇒ Raise the crane lifting gear until it is tensioned.

⇒ Do not stand under suspended loads.

⇒ Do not stand between elements of the truss package.

9. Crane out frame and stack ready for transportation.

Repeat Steps 6 - 9 for all additional frame elements of the truss package.

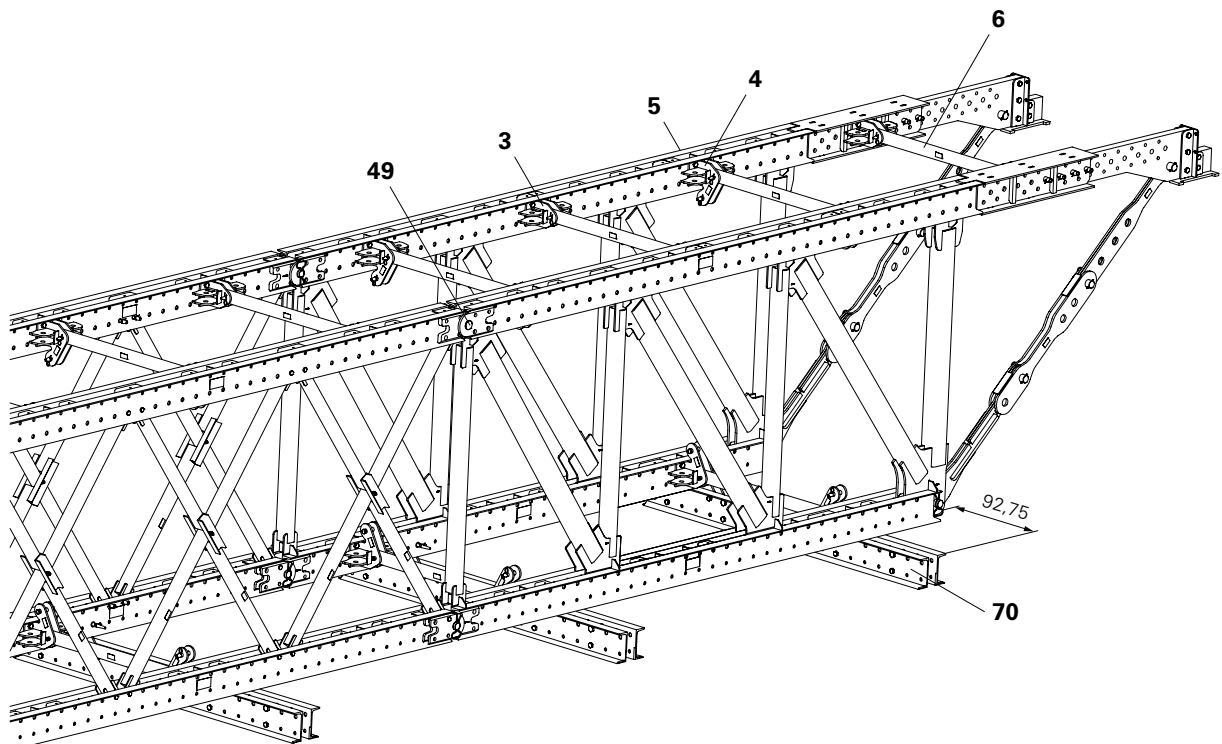

Fig. E2.04

## Notes

Item no.	Weight kg
128086	1120.000

## Bearing Frame 5.25 m VRB

Functional dimension: 5.25 m - 6.00 m.  
Frame for the upper chord support on the Main Beam.

### Complete with

- 1 pc. 125355 Bolt  $\varnothing$  50 x 250, VRB
- 4 pc. 125356 Cotter PIN 6/1  $\varnothing$  50, VRB
- 4 pc. 113626 Bolt  $\varnothing$  50 x 155
- 4 pc. 018060 Cotter Pin 4/1, galv.
- 4 pc. 125347 Fitting Pin  $\varnothing$  30, VRB

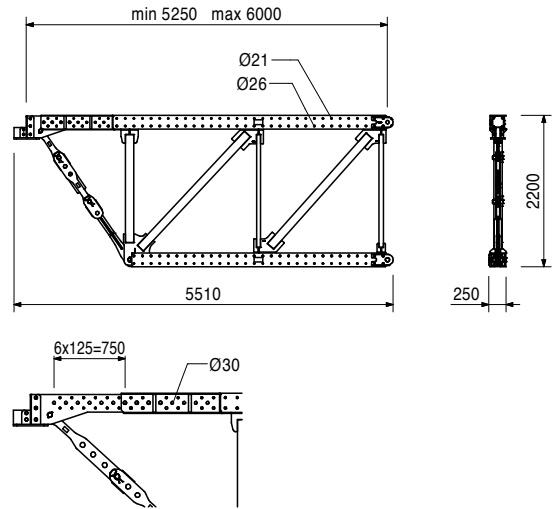
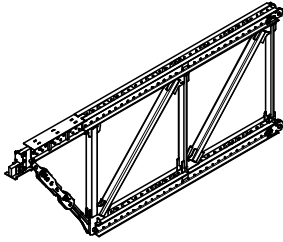

126578	1300.000
--------	----------

## Bearing Frame 6.0 m VRB

Functional dimension: 6.00 m - 6.75 m.  
Frame for the upper chord support on the Main Beam.

### Complete with

- 1 pc. 125355 Bolt  $\varnothing$  50 x 250, VRB
- 4 pc. 125356 Cotter PIN 6/1  $\varnothing$  50, VRB
- 4 pc. 113626 Bolt  $\varnothing$  50 x 155
- 4 pc. 018060 Cotter Pin 4/1, galv.
- 4 pc. 125347 Fitting Pin  $\varnothing$  30, VRB

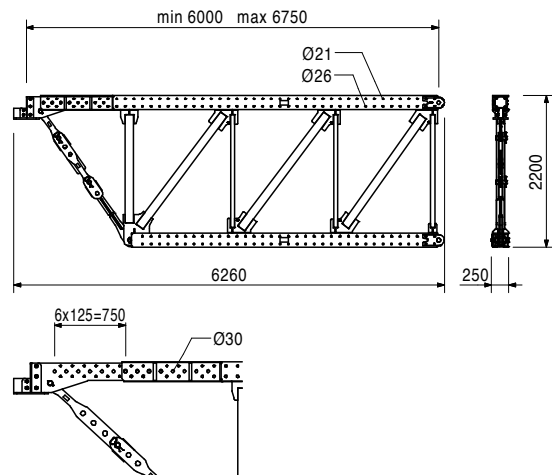
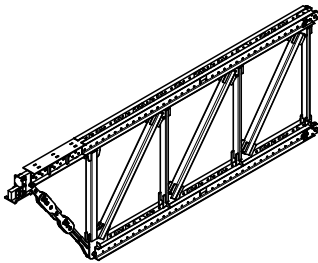

Item no.	Weight kg
125153	401.000

### Coupling Joint Frame 1.5 m VRB

Frame for high shear forces, for bottom chord support of coupling joint suspensions.

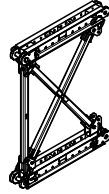

### Complete with

- 1 pc. 125413 Pressure Pole Starter VRB
- 1 pc. 125409 Diagonal Bracing 1.5 m VRB
- 2 pc. 125405 Chord 1.5 m VRB, coat
- 2 pc. 125355 Bolt  $\varnothing$  50 x 250, VRB
- 2 pc. 125356 Cotter PIN 6/1  $\varnothing$  50, VRB
- 4 pc. 125347 Fitting Pin  $\varnothing$  30, VRB
- 4 pc. 018060 Cotter Pin 4/1, galv.

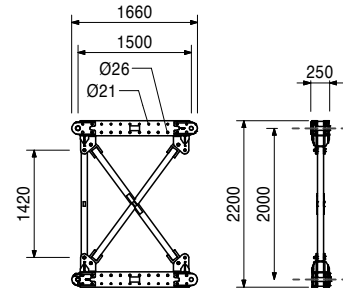

125154	675.000
--------	---------

### Coupling Joint Frame 3.0 m VRB

Frame for high shear forces, for bottom chord support of coupling joint suspensions.

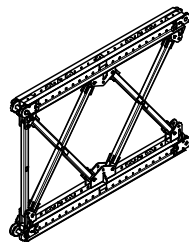

### Complete with

- 1 pc. 125413 Pressure Pole Starter VRB
- 2 pc. 125409 Diagonal Bracing 1.5 m VRB
- 2 pc. 125419 Chord 3,0 m, coat
- 2 pc. 125355 Bolt  $\varnothing$  50 x 250, VRB
- 2 pc. 125356 Cotter PIN 6/1  $\varnothing$  50, VRB
- 8 pc. 125347 Fitting Pin  $\varnothing$  30, VRB
- 8 pc. 018060 Cotter Pin 4/1, galv.

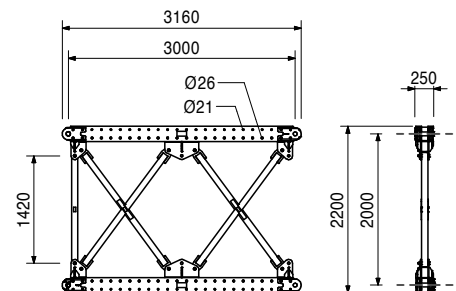

127285	501.000
--------	---------

### Standard Frame 3.0 m VRB

Frame for high bending moment loads.

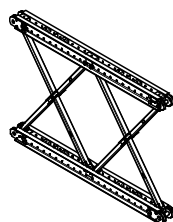

### Complete with

- 2 pc. 127284 Chord 3,0 m, coat
- 2 pc. 125371 Diagonal Pole Interrupted VRB
- 2 pc. 125381 Diagonal Pole Continuous VRB
- 2 pc. 125355 Bolt  $\varnothing$  50 x 250, VRB
- 2 pc. 125356 Cotter PIN 6/1  $\varnothing$  50, VRB
- 4 pc. 125345 Fitting Pin  $\varnothing$  26 x 105, VRB
- 4 pc. 125351 Fitting Pin  $\varnothing$  26 SR, VRB
- 8 pc. 018060 Cotter Pin 4/1, galv.

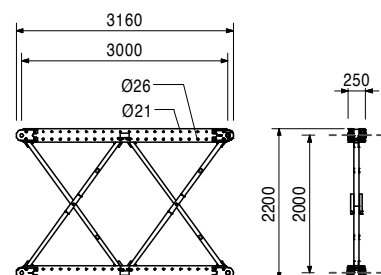

Item no.	Weight kg
125155	709.000

## Standard Frame 4.5 m VRB

Frame for high bending moment loads.

### Complete with

- 2 pc. 125379 Chord 4.5 m VRB, coat
- 2 pc. 125356 Cotter PIN 6/1 Ø 50, VRB
- 3 pc. 125371 Diagonal Pole Interrupted VRB
- 3 pc. 125381 Diagonal Pole Continuous VRB
- 2 pc. 125355 Bolt Ø 50 x 250, VRB
- 4 pc. 125351 Fitting Pin Ø 26 SR, VRB
- 8 pc. 125345 Fitting Pin Ø 26 x 105, VRB
- 12 pc. 018060 Cotter Pin 4/1, galv.

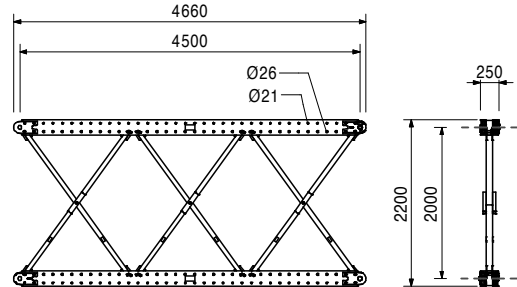
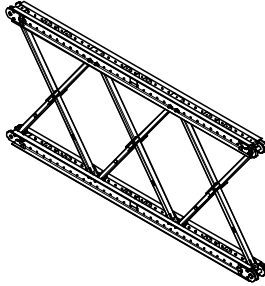

125156	915.000
--------	---------

## Standard Frame 6.0 m VRB

Frame for high bending moment loads.

### Complete with

- 4 pc. 125371 Diagonal Pole Interrupted VRB
- 4 pc. 125381 Diagonal Pole Continuous VRB
- 2 pc. 125387 Chord 6 m, coat
- 2 pc. 125355 Bolt Ø 50 x 250, VRB
- 2 pc. 125356 Cotter PIN 6/1 Ø 50, VRB
- 4 pc. 125351 Fitting Pin Ø 26 SR, VRB
- 12 pc. 125345 Fitting Pin Ø 26 x 105, VRB
- 16 pc. 018060 Cotter Pin 4/1, galv.

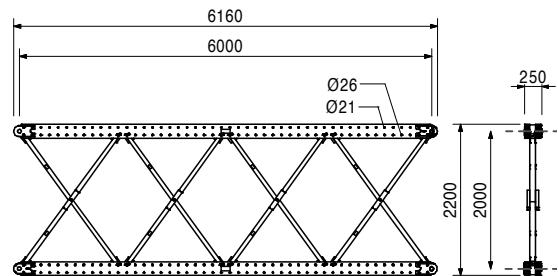
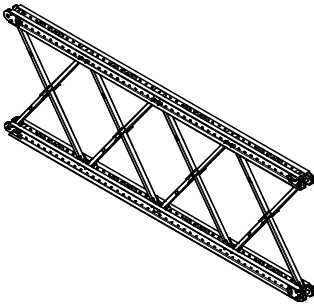

127136	25.200
--------	--------

## Cross Fall Bearing VRB

For supporting the Bearing Frames on the yoke when the Main Beam is inclined transversely > 0% - 7%.

### Complete with

- 2 pc. 111137 Hex Bolt ISO4017 M20 x 55-8.8, galv.

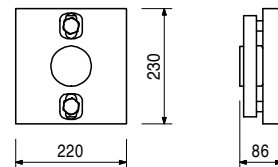
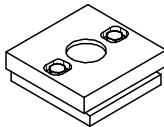

Item no.	Weight kg
127143	12.200

### Longitudinal Bearing VRB

For supporting the Bearing Frames on the Main Beam from 0% - 7% longitudinal inclination.

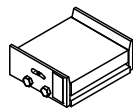

### Complete with

4 pc. 710266 Bolt ISO 4017 M12 x 25-8.8, galv.  
2 pc. 710417 Sleeve ISO 8752-06, 0 x 025,galv.

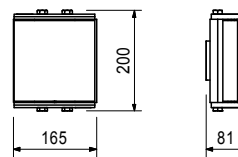

Accessories

128019	13.500
--------	--------

### Centering Plate HDT - VRB

128019	13.500
--------	--------

### Centering Plate HDT - VRB

For centring the Longitudinal Bearing VRB on the Main Beam and for pulling out the Truss Girder from the side during disassembly.

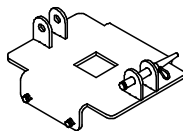

### Complete with

1 pc. 104031 Fitting Pin  $\varnothing$  21 x 120  
1 pc. 018060 Cotter Pin 4/1, galv.  
4 pc. 710328 Hex.Bolt ISO 4017 M10x40-8.8, galv.

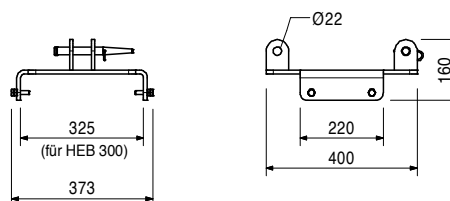

131852	63.300
--------	--------

### Horizontal Bearing-2 VRB

For deriving horizontal forces of the entire system into the Main Beam.

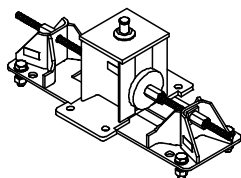

### Complete with

4 pc. 135465 Bolt M24 x 100 10.9

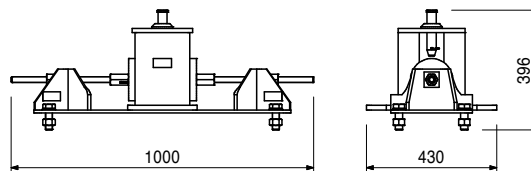

### Note

For using the Cross Fall Adaptor VRB 131031:

Accessories

131031	10.100
--------	--------

### Cross Fall Adaptor VRB

4 x 135465 Bolt M24x100 10.9  
has to be replaced by  
4 x 135464 Bolt M24x180 10.9

131031	10.100
--------	--------

### Cross Fall Adaptor VRB

For the height compensation at the Horizontal Bearing-2 VRB when using Cross Fall Bearing VRB.

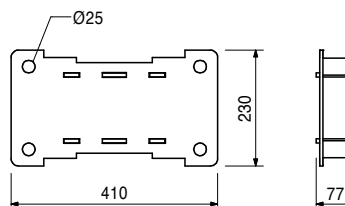
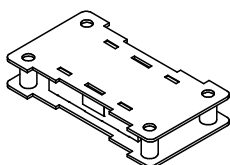

Accessories

131852	63.300
--------	--------

### Horizontal Bearing-2 VRB

Item no.	Weight kg
125764	15.000

### Bracing Shoe VRB

Connection for the horizontal bracing on the top chord of the truss package.

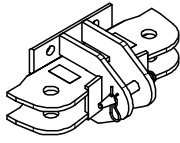

### Complete with

1 pc. 125349 Fitting Pin  $\varnothing$  21 x 105, VRB  
1 pc. 018060 Cotter Pin 4/1, galv.

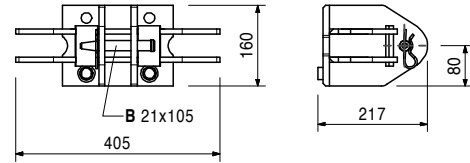

### Accessories

711084	0.420
781053	0.065

**Bolt ISO 4014 M20 x 150-8.8, galv.**  
**Nut ISO 7040 M20-8, galv.**

125770	17.900
--------	--------

### Vertical Bracing Shoe VRB

Connection for the horizontal and vertical bracing on the upper and lower chord of the truss package.

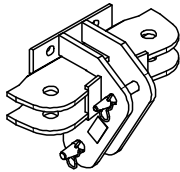

### Complete with

1 pc. 125345 Fitting Pin  $\varnothing$  26 x 105, VRB  
2 pc. 018060 Cotter Pin 4/1, galv.  
1 pc. 125349 Fitting Pin  $\varnothing$  21 x 105, VRB

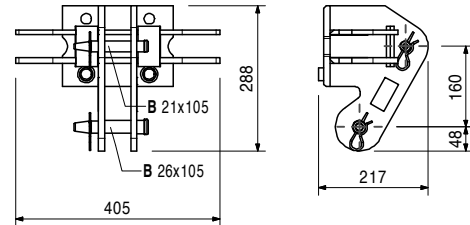

### Accessories

711084	0.420
781053	0.065

**Bolt ISO 4014 M20 x 150-8.8, galv.**  
**Nut ISO 7040 M20-8, galv.**

125732	5.190
--------	-------

### Coupling Shoe VRB

Connection for coupling single trusses to the truss package.

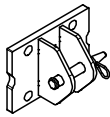

### Complete with

1 pc. 125349 Fitting Pin  $\varnothing$  21 x 105, VRB  
1 pc. 018060 Cotter Pin 4/1, galv.

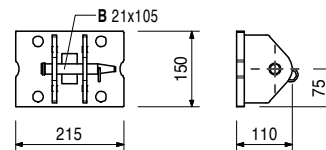

### Accessories

711084	0.420
781053	0.065

**Bolt ISO 4014 M20 x 150-8.8, galv.**  
**Nut ISO 7040 M20-8, galv.**

# VRB Truss Girder

Item no.	Weight kg
125741	7.870

## Articulated Spanner DW 20 VRB

Articulated clamping component for DW20 - bracing in the upper chord.

### Complete with

1 pc. 125347 Fitting Pin Ø 30, VRB  
1 pc. 018060 Cotter Pin 4/1, galv.

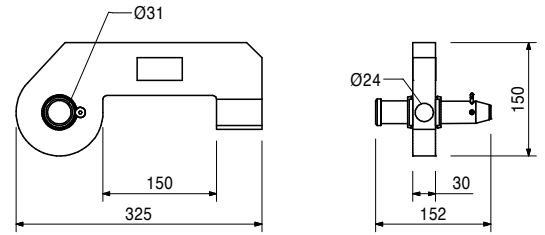
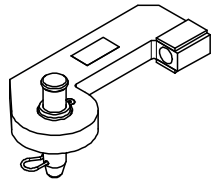

### Accessories

030700	2.560
030580	0.371

## Tie Rod DW 20, spec. length

Hex. Nut DW 20 SW 36/60, weldable

125727	4.020
--------	-------

## Eye Nut DW 20 VRB

Articulated connection component for DW20 - bracing.

### Complete with

1 pc. 125347 Fitting Pin Ø 30, VRB  
1 pc. 018060 Cotter Pin 4/1, galv.

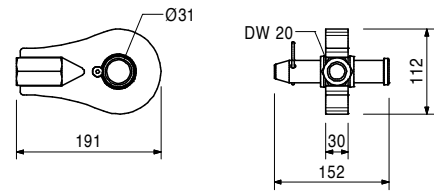
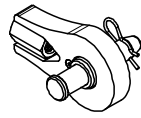

### Accessories

030700	2.560
--------	-------

## Tie Rod DW 20, spec. length

030700	2.560
030800	0.000

## Tie Rod DW 20

Tie Rod DW 20, spec. length

Cutting Cost Tie Rod DW 20/B 20

### Note

Non-weldable! Take official Approval into consideration!

### Technical Data

Permissible tension force 150 kN.

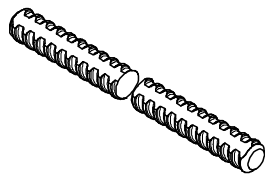

030580	0.371
--------	-------

## Hex. Nut DW 20 SW 36/60, weldable

For anchoring with Tie Rod DW 20 and B 20.

### Note

Weldable!

### Technical Data

Permissible load 150 kN.

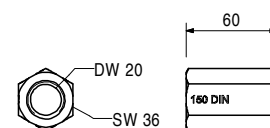
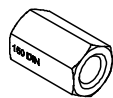

Item no.	Weight kg
115375	6.100

## Articulated Spanner RCS DW 15

For tensioning and as an articulated connection to the Climbing Rail RCS, Steel Waler SRU or Bracing Shoe RCS for bracing with DW 15.

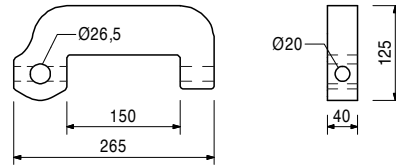
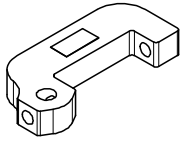

### Accessories

104031	0.462	<b>Fitting Pin Ø 21 x 120</b>
018060	0.014	<b>Cotter Pin 4/1, galv.</b>
111567	0.729	<b>Fitting Pin Ø 26 x 120</b>
022230	0.033	<b>Cotter Pin 5/1, galv.</b>
030070	0.222	<b>Hex. Nut DW 15 SW 30/50, galv.</b>
030030	1.440	<b>Tie Rod DW 15, spec. length</b>

115378	1.080
--------	-------

## Eye Nut RCS DW 15

As an articulated connection to the Climbing Rail RCS, Steel Waler SRU for bracing with DW 15.

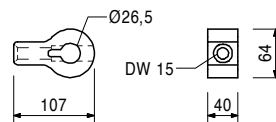

### Accessories

104031	0.462	<b>Fitting Pin Ø 21 x 120</b>
018060	0.014	<b>Cotter Pin 4/1, galv.</b>
111567	0.729	<b>Fitting Pin Ø 26 x 120</b>
022230	0.033	<b>Cotter Pin 5/1, galv.</b>

030030	1.440
030050	0.000

## Tie Rod DW 15

**Tie Rod DW 15, spec. length**  
**Cutting Cost Tie Rod DW 15, B 15**

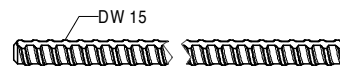
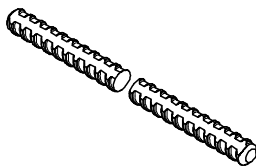

### Note

Non-weldable! Take official Approval into consideration!

### Technical Data

Permissible tension force 90 kN.

030070	0.222
--------	-------

## Hex. Nut DW 15 SW 30/50, galv.

For anchoring with Tie Rod DW 15 and B 15.

### Technical Data

Permissible load 90 kN.

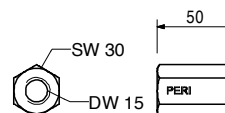

# VRB Truss Girder

Item no.	Weight kg
125736	24.600

## Bracing Post 2.25 m, VRB

Bracing post for a truss package with 2.25 m axis spacing.

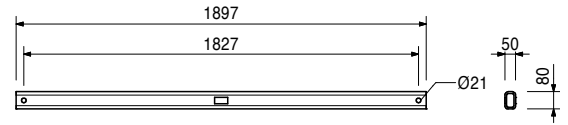
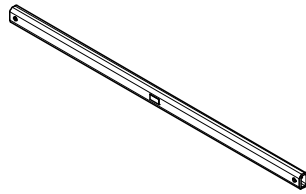

Accessories

125764	15.000
125770	17.900

## Bracing Shoe VRB

## Vertical Bracing Shoe VRB

125734	14.900
--------	--------

## Bracing Post 1.50 m, VRB

Bracing post for a truss package with 1.5 m axis spacing.

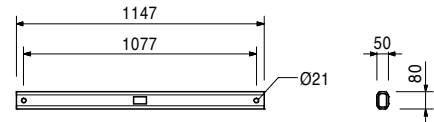
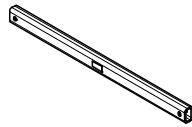

Accessories

125764	15.000
125770	17.900

## Bracing Shoe VRB

## Vertical Bracing Shoe VRB

125756	4.430
--------	-------

## Coupling Post 1.0 m, VRB

Post for coupling single trusses with 1.0 m axis spacing.

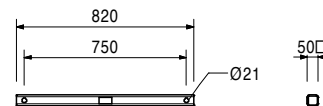
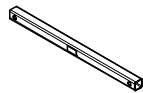

Accessories

125732	5.190
--------	-------

## Coupling Shoe VRB

125746	1.700
--------	-------

## Coupling Post 0.5 m, VRB

Post for coupling single trusses with 0.5 m axis spacing.

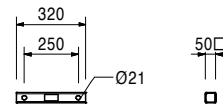

Accessories

125732	5.190
--------	-------

## Coupling Shoe VRB

Item no.	Weight kg
128091	75.900

### Bracing Traverse 150 VRB

For the connection of the truss package (1.5 m) at the Horizontal Bearing-2.

### Complete with

8 pc. 125345 Fitting Pin  $\varnothing$  26 x 105, VRB  
8 pc. 018060 Cotter Pin 4/1, galv.

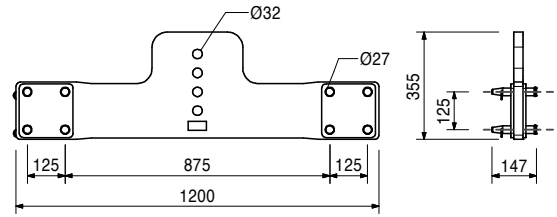
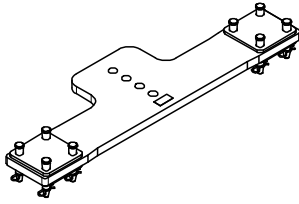

Accessories

131852	63.300
128103	45.000
128098	8.100

### Horizontal Bearing-2 VRB

### Bracing Traverse Connector VRB

### Bracing Spindle VRB

128103	45.000
--------	--------

### Bracing Traverse Connector VRB

For the connection of the truss package (1.5 m) at the Horizontal Bearing-2.

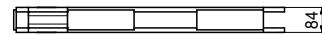
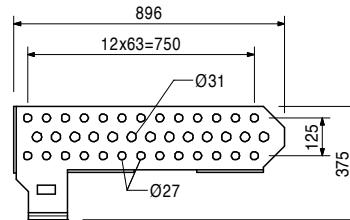
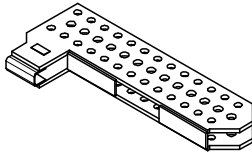

Accessories

128091	75.900
128098	8.100
131852	63.300

### Bracing Traverse 150 VRB

### Bracing Spindle VRB

### Horizontal Bearing-2 VRB

128098	8.100
--------	-------

### Bracing Spindle VRB

For the connection of the truss package (1.5 m) at the Horizontal Bearing-2.

### Complete with

4 pc. 780357 Bolt ISO 4017 M20 x 50-8.8, galv.  
4 pc. 781053 Nut ISO 7040 M20-8, galv.  
2 pc. 128093 TR38 Nut Sher

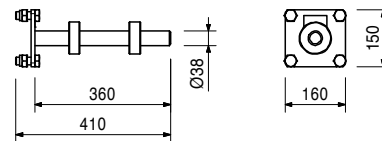
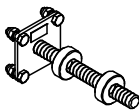

Accessories

128091	75.900
128103	45.000
131852	63.300

### Bracing Traverse 150 VRB

### Bracing Traverse Connector VRB

### Horizontal Bearing-2 VRB

# VRB Truss Girder

Item no.	Weight kg
126059	500.000

## Main Beam 350 VRB

Main Beam for supporting Truss Girder VRB compatible with PERI VST Heavy Duty Shoring Tower.

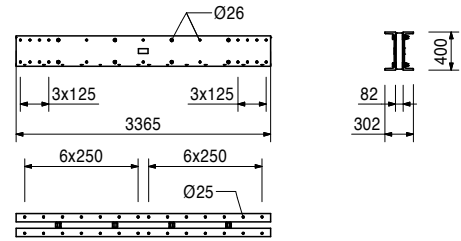
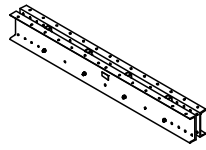

Accessories

126050	78.400
--------	--------

## Main Beam Connector VRB

126062	725.000
--------	---------

## Main Beam 500 VRB

Main Beam for supporting Truss Girder VRB compatible with PERI VST Heavy Duty Shoring Tower.

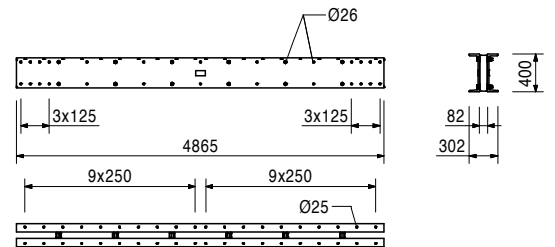
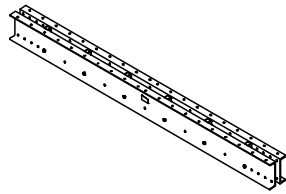

Accessories

126050	78.400
--------	--------

## Main Beam Connector VRB

126065	1170.000
--------	----------

## Main Beam 800 VRB

Main Beam for supporting Truss Girder VRB compatible with PERI VST Heavy Duty Shoring Tower.

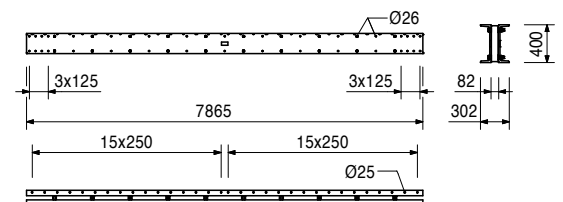
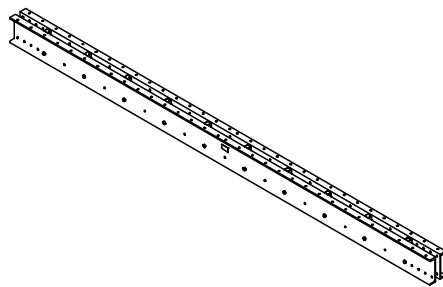

Accessories

126050	78.400
--------	--------

## Main Beam Connector VRB

Item no.	Weight kg
126050	78.400

**Main Beam Connector VRB**  
For the connection of Main Beams VRB.

**Complete with**  
16 pc. 111567 Fitting Pin  $\varnothing$  26 x 120  
16 pc. 022230 Cotter Pin 5/1, galv.

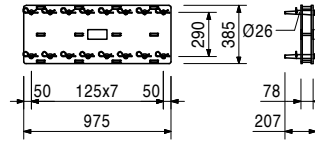
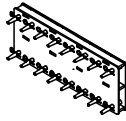

Accessories

126059	500.000
126062	725.000
126065	1170.000

**Main Beam 350 VRB**  
**Main Beam 500 VRB**  
**Main Beam 800 VRB**

125413	28.000
--------	--------

**Pressure Pole Starter VRB**  
Additional pressure pole for the assembly in Coupling Joint Frame 1.5 m VRB and Coupling Joint Frame 3.0 m VRB.

**Complete with**  
2 pc. 125347 Fitting Pin  $\varnothing$  30, VRB  
2 pc. 018060 Cotter Pin 4/1, galv.

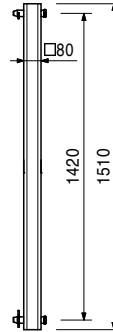

Accessories

125154	675.000
125153	401.000

**Coupling Joint Frame 3.0 m VRB**  
**Coupling Joint Frame 1.5 m VRB**

126355	5.610
--------	-------

**Connector UP- VRB**  
For connecting a PERI UP Scaffold between two truss girders.

**Complete with**  
1 pc. 125345 Fitting Pin  $\varnothing$  26 x 105, VRB  
1 pc. 018050 Pin  $\varnothing$  16 x 65/86, galv.  
2 pc. 018060 Cotter Pin 4/1, galv.

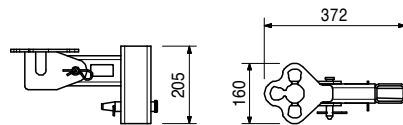
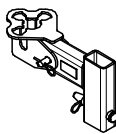

126345	7.390
--------	-------

**Bracket Connector UP-VRB**  
For connecting a PERI UP Bracket Scaffold to a truss girder.

**Complete with**  
1 pc. 018060 Cotter Pin 4/1, galv.  
1 pc. 125345 Fitting Pin  $\varnothing$  26 x 105, VRB

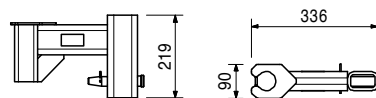
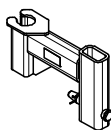

# VRB Truss Girder

Item no.	Weight kg
111567	0.729

**Fitting Pin Ø 26 x 120**  
For different connections.

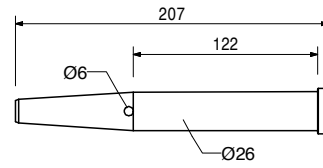
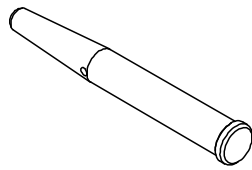

Accessories

022230	0.033
--------	-------

**Cotter Pin 5/1, galv.**

018060	0.014
--------	-------

**Cotter Pin 4/1, galv.**



022230	0.033
--------	-------

**Cotter Pin 5/1, galv.**



125349	0.351
--------	-------

**Fitting Pin Ø 21 x 105, VRB**

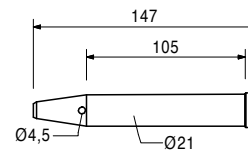
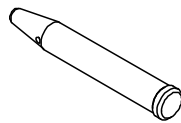

Accessories

018060	0.014
--------	-------

**Cotter Pin 4/1, galv.**

Item no.	Weight kg	
125345	0.548	<b>Fitting Pin Ø 26 x 105, VRB</b>

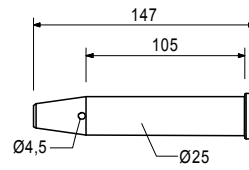
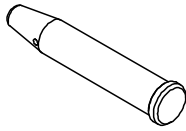

Item no.	Weight kg	Accessories
022230	0.033	<b>Cotter Pin 5/1, galv.</b>

125347	0.800	<b>Fitting Pin Ø 30, VRB</b>
--------	-------	------------------------------

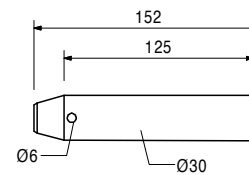
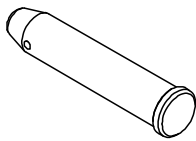

Item no.	Weight kg	Accessories
022230	0.033	<b>Cotter Pin 5/1, galv.</b>

711084	0.420	<b>Bolt ISO 4014 M20 x 150-8.8, galv.</b>
--------	-------	---

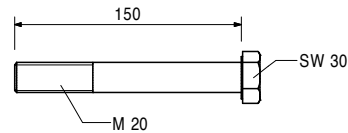
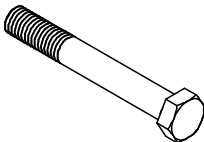

Item no.	Weight kg	Accessories
781053	0.065	<b>Nut ISO 7040 M20-8, galv.</b>

781053	0.065	<b>Nut ISO 7040 M20-8, galv.</b> Self-locking.
--------	-------	---

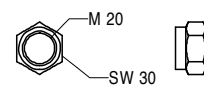

Item no.	Weight kg	
105416	0.360	<b>Bolt ISO 4014 M24 x 80-8.8, galv.</b>

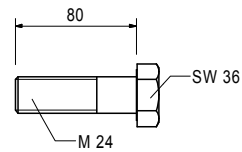
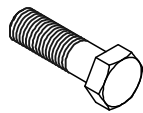

105032	0.070	<b>Nut ISO 7040 M24-8, galv.</b> Self-locking.
--------	-------	---

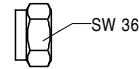

125355	3.850	<b>Bolt Ø 50 x 250, VRB</b> For connecting the Truss Girder VRB-Frames.
--------	-------	--

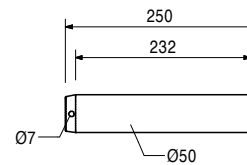
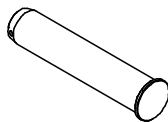

Accessories

125356	0.086	<b>Cotter PIN 6/1 Ø 50, VRB</b>
--------	-------	---------------------------------

125356	0.086	<b>Cotter PIN 6/1 Ø 50, VRB</b>
--------	-------	---------------------------------

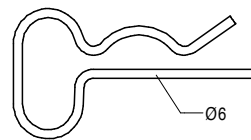
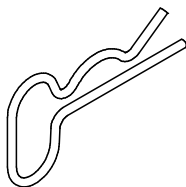

123509	13.400	<b>Cross Connector RCS</b> For crosswise connection of Climbing Rails RCS.
--------	--------	---

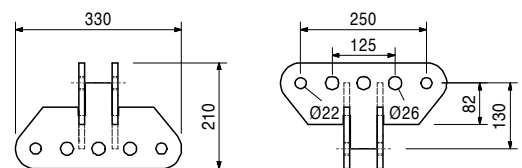
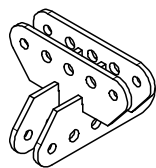

Accessories

104031	0.462	<b>Fitting Pin Ø 21 x 120</b>
018060	0.014	<b>Cotter Pin 4/1, galv.</b>
111567	0.729	<b>Fitting Pin Ø 26 x 120</b>
022230	0.033	<b>Cotter Pin 5/1, galv.</b>

Item no.	Weight kg		L
114166	78.200	<b>Climbing Rails RCS</b>	1480
109469	130.000	<b>Climbing Rail RCS 148</b>	2480
112102	156.000	<b>Climbing Rail RCS 248</b>	2980
109470	182.000	<b>Climbing Rail RCS 298</b>	3480
112141	209.000	<b>Climbing Rail RCS 348</b>	3980
109471	262.000	<b>Climbing Rail RCS 398</b>	4980
109472	393.000	<b>Climbing Rail RCS 498</b>	7480
109610	524.000	<b>Climbing Rail RCS 748</b>	9980

Steel profile for all-purpose use of climbing application or civil constructions. With Spacers M20-82 and M24-82.

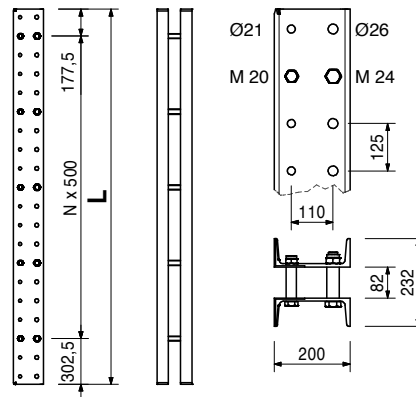

110022	0.491	<b>Spacer M20-82</b> Spacer for Climbing Rails RCS.	<b>Complete with</b> 1 pc. 104477 Bolt ISO 4014 M20 x 120-8.8, galv. 1 pc. 130341 Nut ISO 7042 M20-8, galv.
--------	-------	--	---

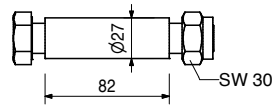
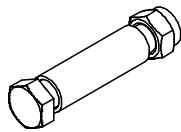

110023	0.910	<b>Spacer M24-82</b> Spacer for Climbing Rails RCS.	<b>Complete with</b> 1 pc. 109612 Bolt ISO 4014 M24 x 130-8.8, galv. 1 pc. 130342 Nut ISO 7042 M24-8, galv.
--------	-------	--	---

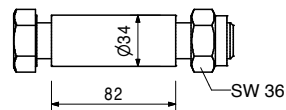
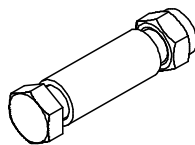



# PERI International

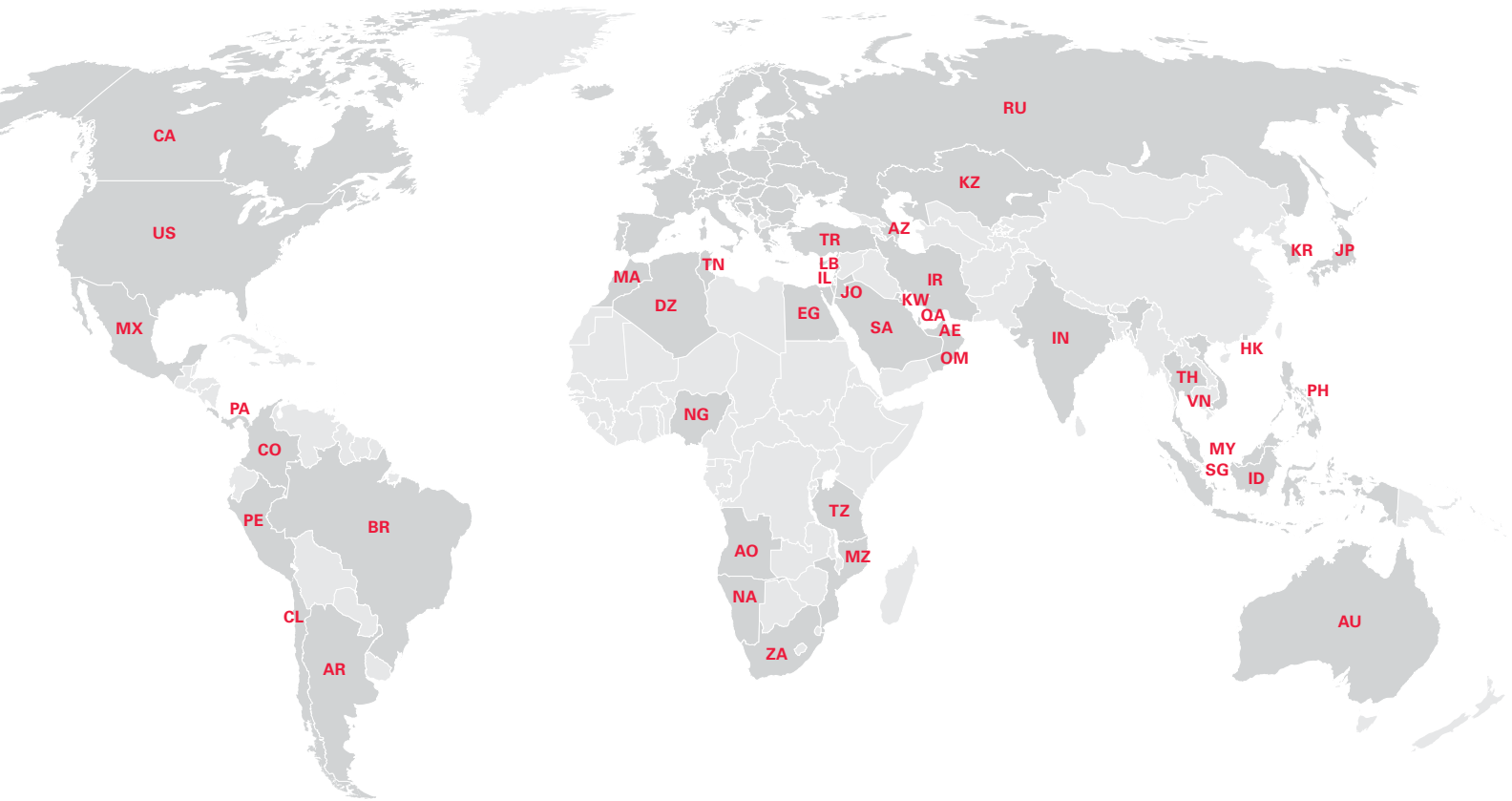

## North America

- CA** Canada  
PERI Formwork Systems, Inc.  
[www.peri.ca](http://www.peri.ca)
- MX** Mexico  
PERI Cimbras y Andamios, S.A. de C.V.  
[www.peri.com.mx](http://www.peri.com.mx)
- PA** Panama  
PERI Panama Inc.  
[www.peri.com.pa](http://www.peri.com.pa)
- US** USA  
PERI Formwork Systems, Inc.  
[www.peri-usa.com](http://www.peri-usa.com)

## South America

- AR** Argentina  
PERI S.A.  
[www.peri.com.ar](http://www.peri.com.ar)
- BR** Brazil  
PERI Formas e Escoramentos Ltda.  
[www.peribrasil.com.br](http://www.peribrasil.com.br)
- CL** Chile  
PERI Chile Ltda.  
[www.peri.cl](http://www.peri.cl)
- CO** Colombia  
PERI S.A.S.  
[www.peri.com.co](http://www.peri.com.co)
- PE** Peru  
PERI Peruana S.A.C.  
[www.peri.com.pe](http://www.peri.com.pe)

## Africa

- AO** Angola  
Pericofragens, Lda.  
[www.peri.pt](http://www.peri.pt)
- DZ** Algeria  
S.A.R.L. PERI  
[www.peri.dz](http://www.peri.dz)
- EG** Egypt  
Egypt Branch Office  
[www.peri.com.eg](http://www.peri.com.eg)
- MA** Morocco  
PERI S.A.  
[www.peri.ma](http://www.peri.ma)
- MZ** Mozambique  
PERI (Pty.) Ltd.  
[www.peri.co.mz](http://www.peri.co.mz)
- NA** Namibia  
PERI (Pty.) Ltd.  
[www.peri.na](http://www.peri.na)
- NG** Nigeria  
PERI Nigeria Ltd.  
[www.peri.ng](http://www.peri.ng)
- TN** Tunisia  
PERI S.A.U.  
[www.peri.es](http://www.peri.es)
- TZ** Tanzania  
PERI Formwork and Scaffolding Ltd  
[www.peri.co.tz](http://www.peri.co.tz)
- ZA** South Africa  
PERI Formwork Scaffolding (Pty) Ltd  
[www.peri.co.za](http://www.peri.co.za)

## Asia

- AE** United Arab Emirates  
PERI (L.L.C.)  
[www.peri.ae](http://www.peri.ae)
- AZ** Azerbaijan  
PERI Representative Office  
[www.peri.com.tr](http://www.peri.com.tr)
- HK** Hong Kong  
PERI (Hong Kong) Limited  
[www.perihk.com](http://www.perihk.com)
- ID** Indonesia  
PT Beton Perkasa Wijaksana  
[www.betonperkasa.com](http://www.betonperkasa.com)
- IL** Israel  
PERI F.E. Ltd.  
[www.peri.co.il](http://www.peri.co.il)
- IN** India  
PERI (India) Pvt Ltd  
[www.peri.in](http://www.peri.in)
- IR** Iran  
PERI Pars. Ltd.  
[www.peri.ir](http://www.peri.ir)
- JO** Jordan  
PERI GmbH – Jordan  
[www.peri.com](http://www.peri.com)
- JP** Japan  
PERI Japan K.K.  
[www.peri.co.jp](http://www.peri.co.jp)
- KR** Korea  
PERI (Korea) Ltd.  
[www.perikorea.com](http://www.perikorea.com)
- KW** Kuwait  
PERI Kuwait W.L.L.  
[www.peri.com.kw](http://www.peri.com.kw)
- KZ** Kazakhstan  
TOO PERI Kazakhstan  
[www.peri.kz](http://www.peri.kz)
- LB** Lebanon  
PERI Lebanon Sarl  
[lebanon@peri.de](mailto:lebanon@peri.de)
- MY** Malaysia  
PERI Formwork Malaysia Sdn. Bhd.  
[www.perimalaysia.com](http://www.perimalaysia.com)
- OM** Oman  
PERI (L.L.C.)  
[www.peri.ae](http://www.peri.ae)
- PH** Philippines  
PERI-Asia Philippines, INC.  
[www.peri.com.ph](http://www.peri.com.ph)
- QA** Qatar  
PERI Qatar LLC  
[www.peri.qa](http://www.peri.qa)
- SA** Saudi Arabia  
PERI Saudi Arabia Ltd.  
[www.peri.com.sa](http://www.peri.com.sa)
- SG** Singapore  
PERI Asia Pte Ltd  
[www.periasia.com](http://www.periasia.com)
- TH** Thailand  
Peri (Thailand) Co., Ltd.  
[www.peri.co.th](http://www.peri.co.th)
- TR** Turkey  
PERI Kalıp ve İskeleleri  
[www.peri.com.tr](http://www.peri.com.tr)
- VN** Vietnam  
PERI ASIA PTE LTD  
[www.peri.com.vn](http://www.peri.com.vn)



**PERI**

**PERI GmbH  
Formwork Scaffolding Engineering**

Rudolf-Diesel-Strasse 19  
89264 Weissenhorn  
Germany  
Tel. +49 (0)7309.950-0  
Fax +49 (0)7309.951-0  
info@peri.com  
www.peri.com

**Oceania**

**AU** Australia  
PERI Australia Pty. Ltd.  
www.periaus.com.au

**DK** Denmark  
PERI Danmark A/S  
www.peri.dk

**IT** Italy  
PERI S.r.l.  
www.peri.it

**SE** Sweden  
PERI Sverige AB  
www.peri.se

**Europe**

**EE** Estonia  
PERI AS  
www.peri.ee

**LT** Lithuania  
PERI UAB  
www.peri.lt

**SI** Slovenia  
PERI oplate i skele d.o.o  
www.peri.com.hr

**AL** Albania  
PERI Kalıp ve İskeleleri  
www.peri.com.tr

**ES** Spain  
PERI S.A.U.  
www.peri.es

**LU** Luxembourg  
N.V. PERI S.A.  
www.peri.lu

**SK** Slovakia  
PERI spol. s. r.o.  
www.peri.sk

**AT** Austria  
PERI Ges.mbh  
www.peri.at

**FI** Finland  
PERI Suomi Ltd. Oy  
www.perisuomi.fi

**LV** Latvia  
PERI SIA  
www.peri-latvija.lv

**UA** Ukraine  
TOW PERI  
www.peri.ua

**BA** Bosnia and Herzegovina  
PERI oplate i skele d.o.o  
www.peri.com.hr

**FR** France  
PERI S.A.S.  
www.peri.fr

**NL** Netherlands  
PERI b.v.  
www.peri.nl

**BE** Belgium  
PERI N.V.  
www.peri.be

**GB** United Kingdom  
PERI Ltd.  
www.peri.ltd.uk

**NO** Norway  
PERI Norge AS  
www.peri.no

**BG** Bulgaria  
PERI Bulgaria EOOD  
www.peri.bg

**GR** Greece  
PERI Hellas Ltd.  
www.perihellas.gr

**PL** Poland  
PERI Polska Sp. z o.o.  
www.peri.com.pl

**BY** Belorussia  
IOOO PERI  
www.peri.by

**HR** Croatia  
PERI oplate i skele d.o.o.  
www.peri.com.hr

**PT** Portugal  
Pericofragens Lda.  
www.peri.pt

**CH** Switzerland  
PERI AG  
www.peri.ch

**HU** Hungary  
PERI Kft.  
www.peri.hu

**RO** Romania  
PERI România SRL  
www.peri.ro

**CZ** Czech Republic  
PERI spol. s r.o.  
www.peri.cz

**IR** Ireland  
Siteserv Access & Formwork  
www.siteservaccess.ie

**RS** Serbia  
PERI oplate d.o.o.  
www.peri.rs

**DE** Germany  
PERI GmbH  
www.peri.de

**IS** Iceland  
Armar ehf.  
www.armor.is

**RU** Russia  
OOO PERI  
www.peri.ru

**The optimal System  
for every Project and  
every Requirement**



**Wall Formwork**



**Column Formwork**



**Slab Formwork**



**Climbing Systems**



**Bridge Formwork**



**Tunnel Formwork**



**Shoring Systems**



**Construction Scaffold**



**Facade Scaffold**



**Industrial Scaffold**



**Access**



**Protection Scaffold**



**Safety Systems**



**System-Independent  
Accessories**



**Services**



**PERI GmbH**  
**Formwork Scaffolding Engineering**  
 Rudolf-Diesel-Strasse 19  
 89264 Weissenhorn  
 Germany  
 Tel. +49 (0)7309.950-0  
 Fax +49 (0)7309.951-0  
 info@peri.com  
 www.peri.com

