

PERI ACS Core 400

The efficient and powerful self-climbing formwork for high-rise building cores with innovative climbing hydraulics

Product Brochure – Edition 01/2018

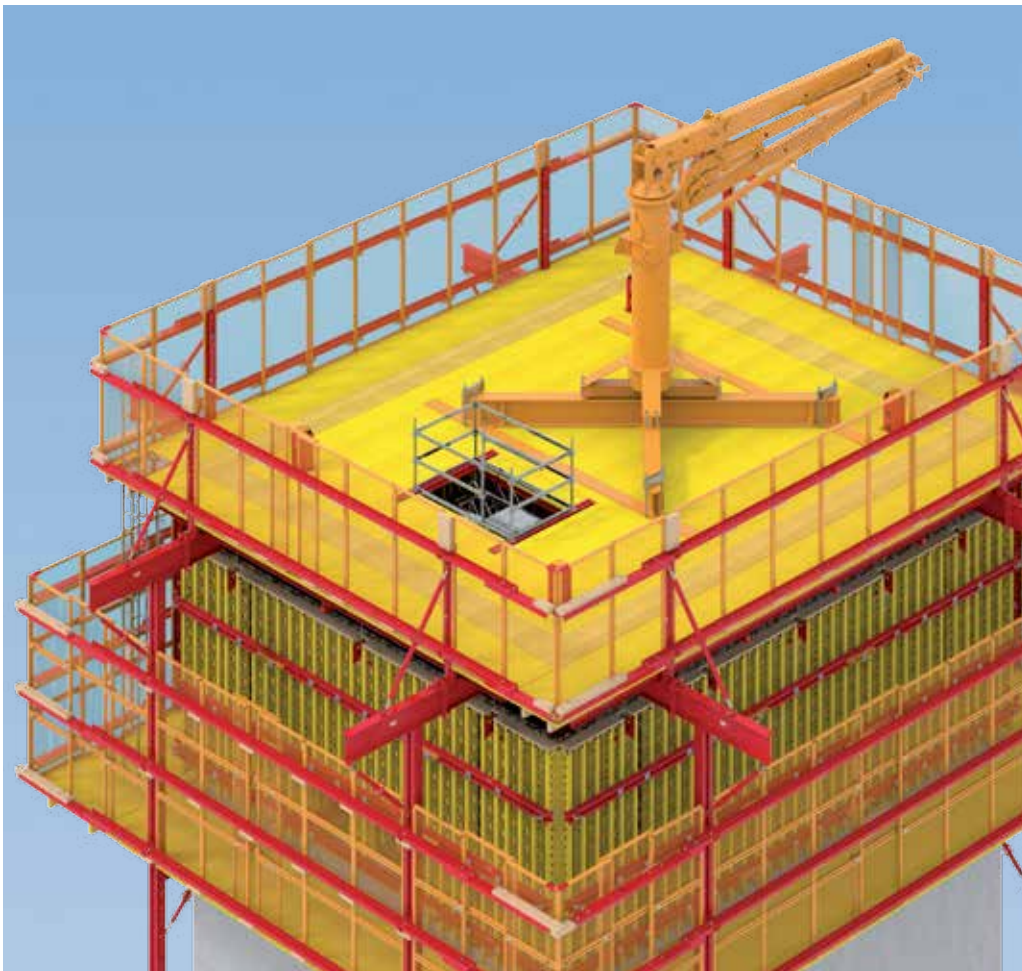

Content

PERI Self-Climbing Technology	
4	Development of the climbing technology
System advantages of the ACS Core 400	
7	The efficient and powerful self-climbing formwork for high-rise building cores
8	System variants of the ACS Core 400
10	Convenient, high load-bearing working platforms
12	Cost-effective tie technology
14	Fast and safe climbing in one lift
System Overview and Application Details	
16	ACS Core 400 at a glance
18	The ACS Core 400 climbing procedure
20	Suspension and support of the wall formwork, guardrails, positioning of the placing boom
22	Fast striking operations

Edition 01 | 2018

Publisher

PERI GmbH
Formwork Scaffolding Engineering
Rudolf-Diesel-Strasse 19
89264 Weissenhorn
Germany
info@peri.com
www.peri.com

Engineering and Services

- 24 PERI services for the best results
- 26 Individual solutions – implemented in partnership
- 27 PERI services: technical processing
- 28 PERI services: pre-assembly and logistics
- 29 PERI services: project management on the construction site

Project Examples

- 30 ACS Core 400 in use: reference projects with the self-climbing formwork

Important information

All current safety regulations and guidelines applicable in those countries where our products are used must be observed.

The images shown in this brochure feature construction sites in progress. For this reason, safety and anchor details in particular cannot always be considered conclusive or final. These are subject to the risk assessment carried out by the contractor.

In addition, computer graphics are used which are to be understood as system representations. To ensure a better understanding, these and the detailed illustrations shown have been partially

reduced to show certain aspects. The safety installations which have possibly not been shown in these detailed descriptions must nevertheless still be available. The systems or items shown might not be available in every country.

Safety instructions and load specifications are to be strictly observed at all times. Separate structural calculations are required for any deviations from the standard design data.

The information contained herein is subject to technical changes in the interests of progress. Errors and typographical mistakes reserved.

The development of the PERI self-climbing technology

More than four decades of experience, continuously optimized systems and high professional competence for your projects

PERI self-climbing technology streamlines construction work as far as possible. Frequently, only physical laws such as the setting time of the fresh concrete limit any further acceleration of the construction progress. In this respect, PERI specialists provide valuable advice and support for realizing ever high structure. With their know-how and vast experience, they can find the most economical solutions for a broad range of projects.

Development of the first PERI climbing formwork began in April 1972 with patent no. DE 2217 584. In the same year, large formwork elements were used on a retractable climbing scaffold for the first time for the construction of the Dresdner Bank building in Mannheim. This design significantly rationalised the construction of high buildings because formwork and climbing scaffold could be moved with a single pick of the crane. The formwork was retracted on the scaffold, cleaned and then closed again.

Further developments regarding self-climbing solutions through hydraulic applications, i.e. eliminating the use a crane, already took place in the 1970s. In particular, the savings made on crane requirements made climbing formwork fast and inexpensive.

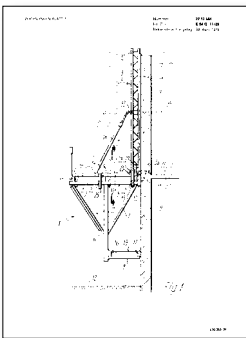

1972
PERI Climbing and Travelling Formwork (crane-climbed) – here an extract from the patent specification

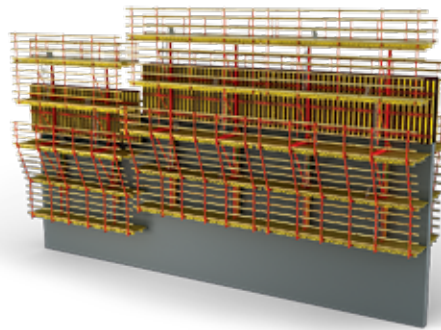

1989
ACS Automatic Climbing System (self-climbed)



1994
ACS P for high-rise cores in advance, here in combination with the ACS G with Gallows (self-climbing)

1974
Kümmel Nuclear Power Plant, Germany (KGF, VARIO GT 24)



1994
Petronas Towers, Kuala Lumpur, Malaysia (ACS, VARIO GT 24)



1998
Park Tower Chicago, United States (ACS, TRIO, SKYDECK)



Today's modular systems – PERI ACS Automatic Climbing System and RCS Rail Climbing System – are products resulting from modern engineering expertise. In particular, the high degree of flexibility along with the combinations of different execution variants offer highly efficient solutions for every project requirement.

With the ACS Core 400, PERI has set yet another milestone in the history of climbing technology: the new PERI self-climbing system provides even more speed, safety and efficiency for forming reinforced concrete cores of high-rise buildings. The new high-performance hydraulics lift the complete platform, placing boom, formwork as well as suspended working platforms to the next level in only 20 minutes.



2005
RCS Rail Climbing System (crane and self-climbed)

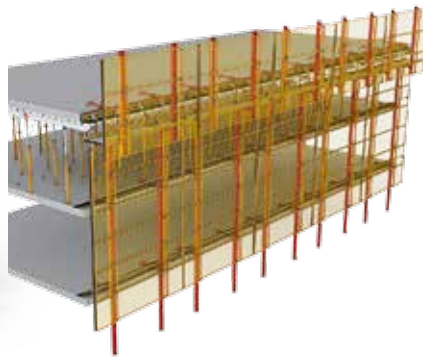

2013
LPS Screen (crane and self-climbed)



2015
ACS Core 400 (self-climbed)

2005
The Regatta Condominium Tower, Chicago, United States (RCS)



2015
555 Tenth Avenue Residential and Office Complex, New York, United States (LPS)



2016
CEB Tower at Rosslyn Central Place, Arlington, VA, USA (ACS Core 400)



PERI ACS Core 400

The efficient and powerful self-climbing formwork for high-rise building cores with innovative climbing hydraulics

With the ACS Core 400 for high-rise building cores with large cell dimensions, the PERI self-climbing technology executed its next evolutionary step: the optimized climbing process ensures simple working operations and short cycle times. Climbing the complete core formwork minimizes leading edges and increases safety levels for the

construction team. In addition, large placing booms can be climbed together with the ACS Core 400, which also supports them during operations. As a result, storey slabs can be simultaneously concreted with the walls. It makes sense to use the system on structures with at least 30 storeys; up to 2 floors per week can be realized.



The ACS Core 400 system has been optimized for massive high-rise building cores with large cell dimensions, and wall heights from 2.70 m to 4.88 m. The complete core formwork climbs continuously in one lift. Thereby, this makes the system the most suitable alternative when very short construction times are required.

Ideally, the ACS Core 400 is combined with VARIO GT 24 Girder Wall Formwork and specially developed corner

and striking elements. Optionally, striking is carried out hydraulically with a single press of a button. Alternatively, the system can be used with MAXIMO or TRIO Panel Formwork systems.

The long-stroke cylinders each have a lifting power of 40 t. A systematic oil flow control ensures synchronous climbing of the entire internal and external formwork – also with large load differences.

Spacious and particularly stable platforms ensure safe, comfortable working conditions and the required load-bearing capacity for material storage. In addition, the ACS Core 400 allows the use of placing booms with a very large reach and can be used without any additional load-bearing system during operations.

Convenient, high load-bearing working platforms

Large-sized platforms for all work operations and for supporting the placing boom when in use

Cost-effective tie technology

Only 2 tie points per support point along with reusable climbing anchors save costs

Fast and safe climbing in one lift

Synchronous climbing without any leading edges featuring an innovative hydraulic system



With the ACS Core 400, walls and slabs can also be concreted in one pour. For this, very large placing booms are used.

System variants of the ACS Core 400

Solutions for a wide range of construction processes

Concreting of advancing cores

If the core is concreted in advance, the load-bearing platform beams cantilever beyond the outer edge of the building core in order to support the enclosure posts. Apart from the external formwork, generously-sized working platforms are also attached to the platform beams.

The external working platforms (Level 0) provide access and storage space for all work which is required on the outer side of the core. The external formwork can be retracted a large distance, and the wide Level 0 working platforms allow here working in front of as well as behind the formwork. This simplifies and accelerates in particular the reinforcement work.

For secure access to all working levels, PERI UP stair towers and the PERI ladder system are normally integrated into the solution.

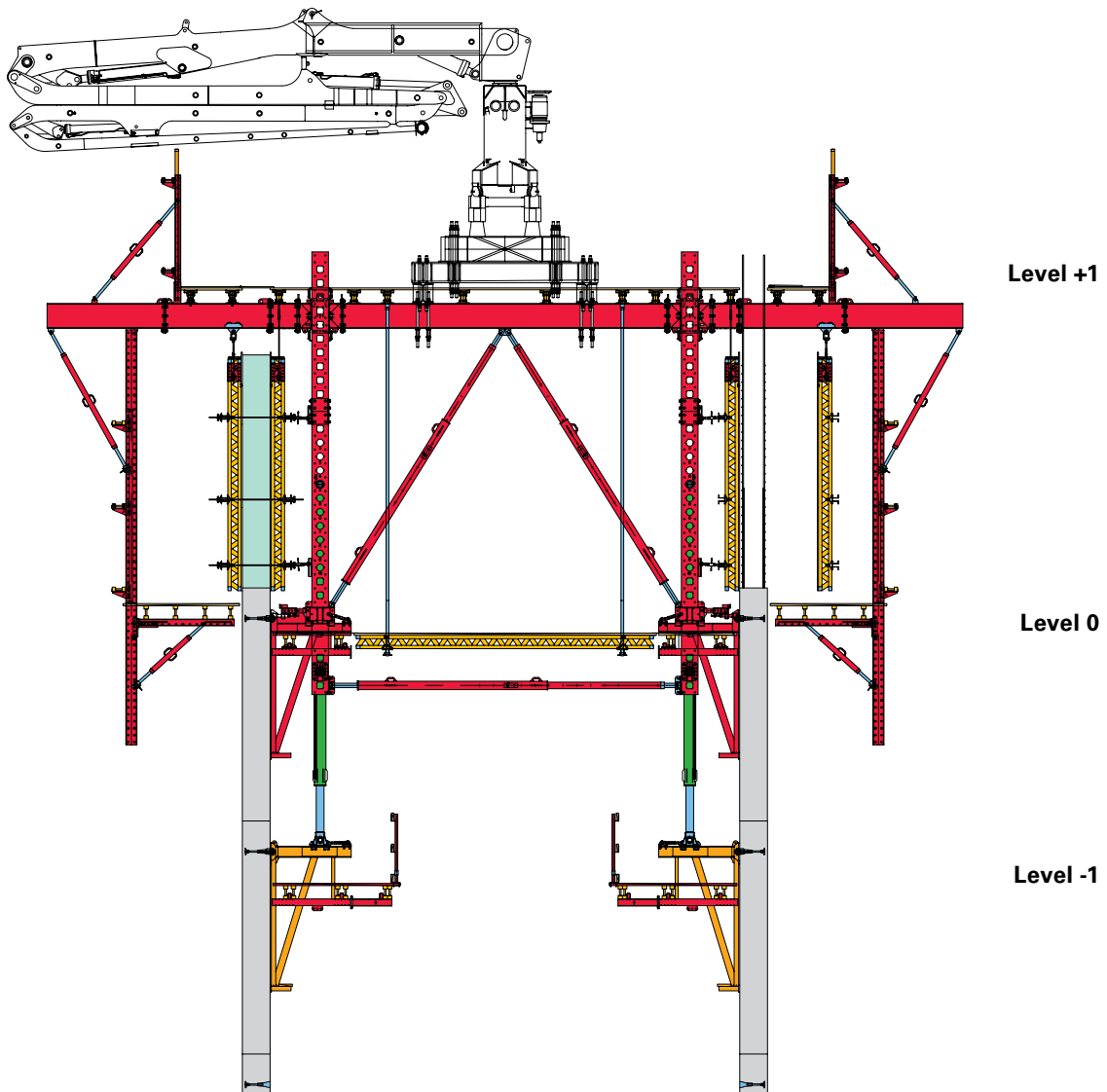

Concreting the wall and slab in one pour

If the floor slabs and walls are simultaneously concreted, suspending the working platform on the external formwork is not required. Work on the outer sides of the core is then carried out from the slab formwork.

The placing boom on the Level +1 working platform typically has a large reach which means the complete slab area can be reached. If required, the slab for the access areas (so-called lobby slabs) is concreted within the core itself. In order to be able to

position the slab formwork on the previous access slab, the inner Level 0 working platform is recessed together with the floor slab. Directly after concreting the slab, the walls for all intents and purposes are concreted in one pour.

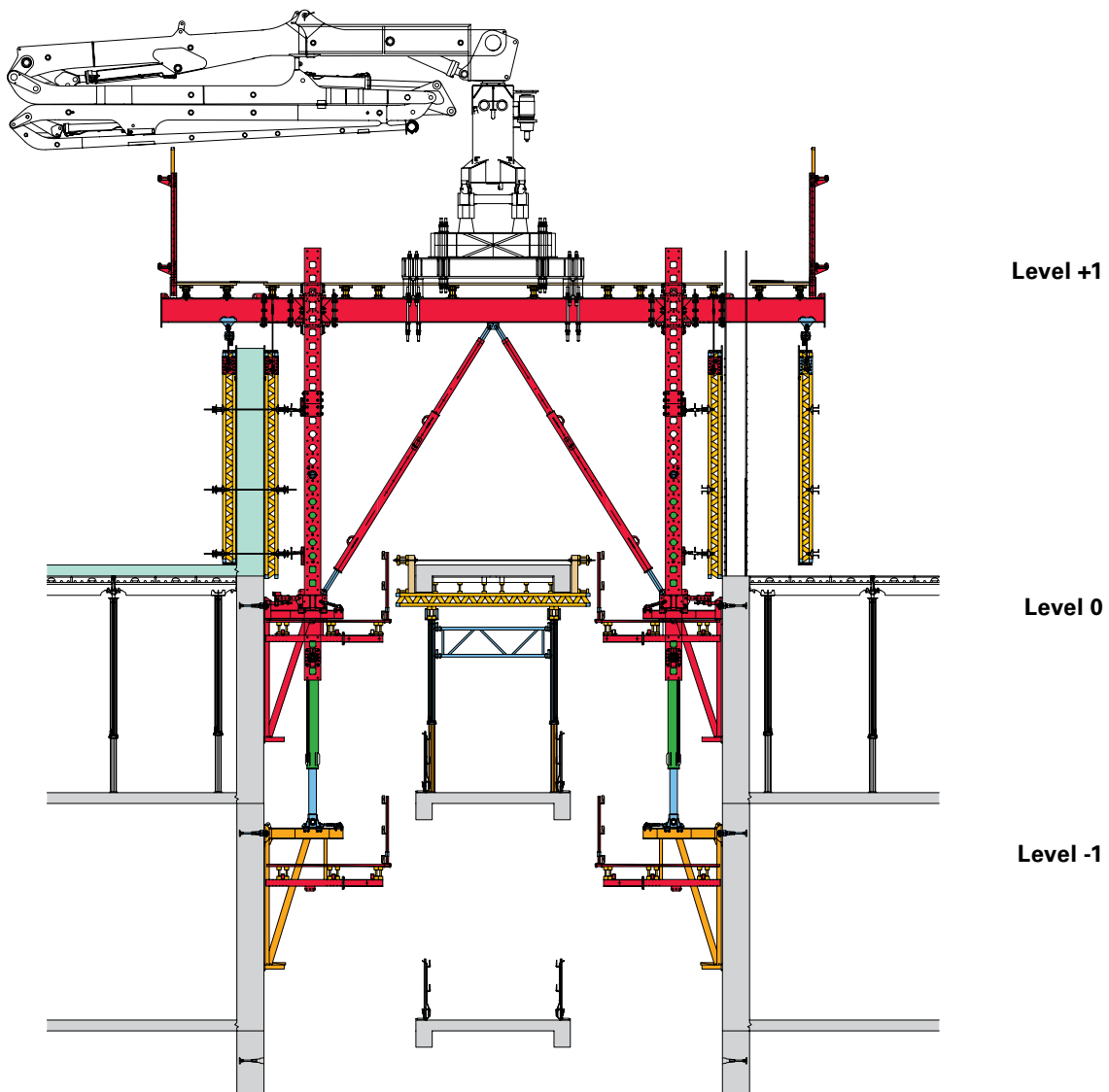

Conveniently sized, high load-bearing working platforms

Large-sized platforms for all work operations and for supporting the placing boom when in use

Through its large-sized platforms, the ACS Core 400 offers the best prerequisites for safe, fast working and material storage. In addition, a placing boom with a large reach can be climbed at the same time.

For the often complex reinforcement work, ACS Core 400 offers a lot of space on Level 0 resulting in high freedom of movement. When the external formwork is retracted, work can take place in front of and behind the formwork.

Due to the high load-bearing capacity of all platforms, all required materials and equipment can be comfortably stored.

The top platform also provides generous working areas. Furthermore, it carries the placing boom which does not have to be additionally supported or anchored either during climbing or when in use.

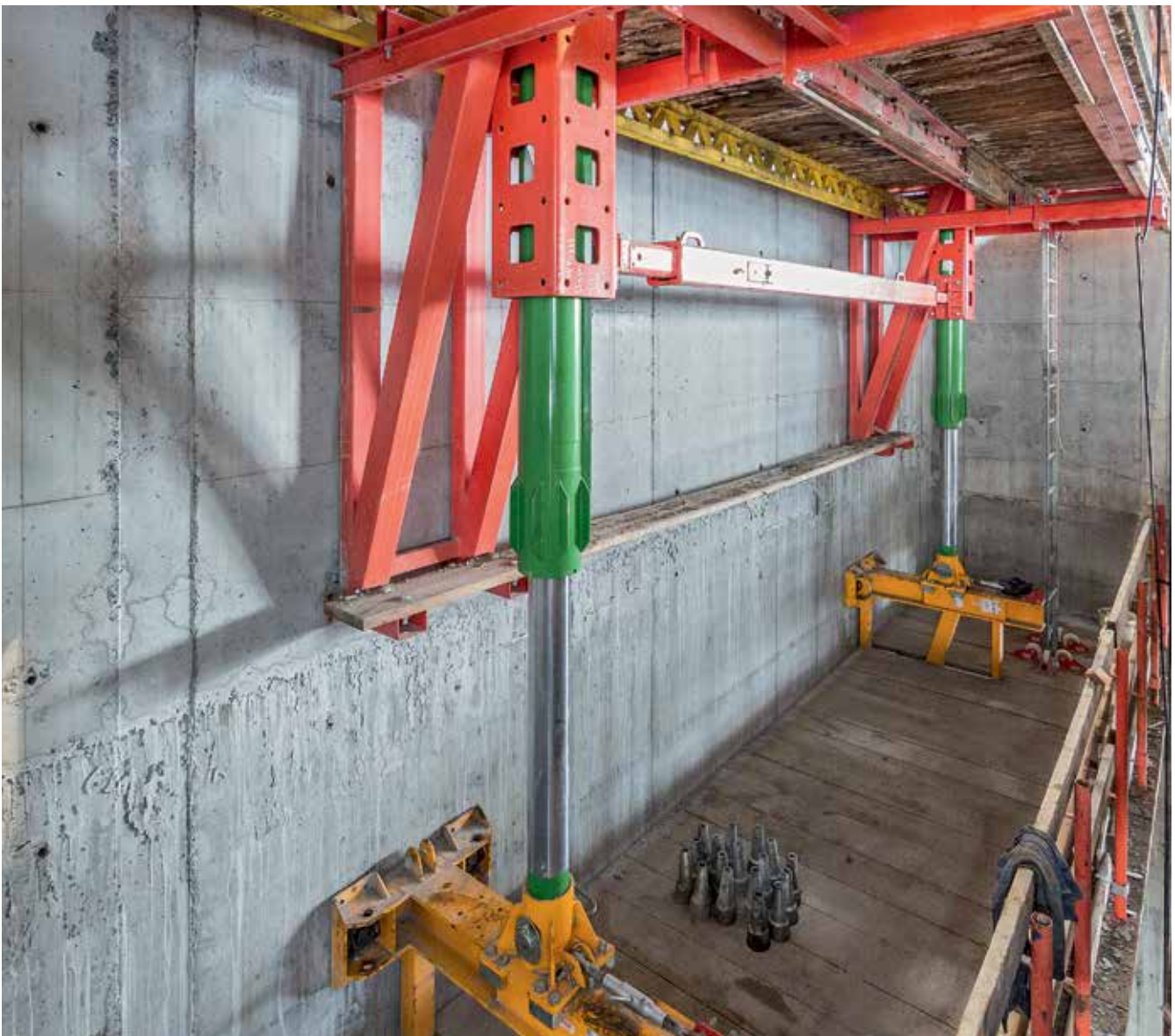

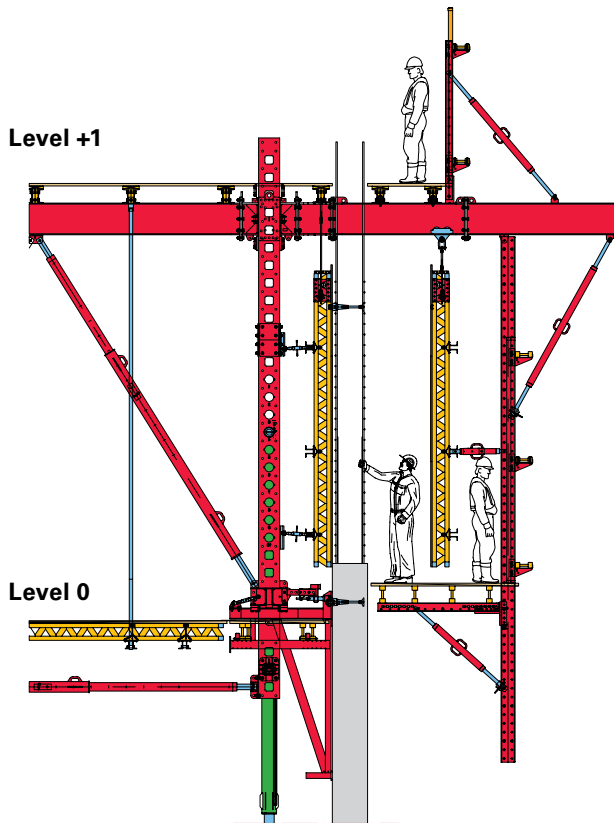

If the external formwork has been retracted, Level 0 provides working space on both sides of the formwork. As the Level +1 working platform is narrower, materials can be brought in by crane.



If the core is concreted in advance, Level 0 provides a continuous storage and working area. PERI UP stair towers and the PERI ladder system ensure secure access solutions to all working levels.

Safe access for concreting

The transverse and longitudinal beams for the girder grid of the ACS Core 400 are installed on the same level on a crosshead. Consequently, the top edge of all beams is at one level resulting in a low overall height.

The height of the girder grid can be adjusted in 125 mm increments so that the difference in height between the working area and the top edge of the wall formwork is always very small. As a result, this makes concreting easier as the formwork is easily visible and optimally accessible.

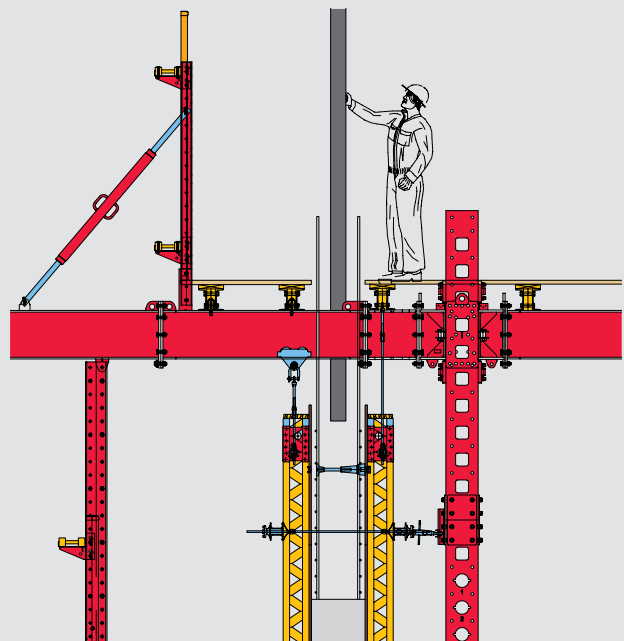

Cost-effective tie technology

Only 2 tie points per bearing point along with reusable climbing anchors save costs

The costs regarding the anchoring of a climbing system always greatly influence the overall costs. With the ACS Core 400, the number of anchors required has been minimized; the system requires only two reusable climbing anchors per bearing point. In addition, the working and climbing brackets use the same tie points in each case.

A new type of heavy-load anchor is used for anchoring the brackets so that only two anchors are required per bearing point. As the installation of the lost components is time-consuming and expensive due to the high amount of reinforcement often used in the core walls, the minimized number of tie points significantly reduces the workload.

Thanks to their special geometry, the climbing anchors can also be easily removed and re-used for subsequent floors. In addition to the workload, this reduces the costs of the lost components. As working and climbing brackets are arranged directly above each other and mounted in the same tie positions, this ensures additional cost optimization.

For simple assembly of the brackets, an Anchor Sliding Piece is used which provides +/- 10 mm clearance in the horizontal and vertical directions.

Working Bracket

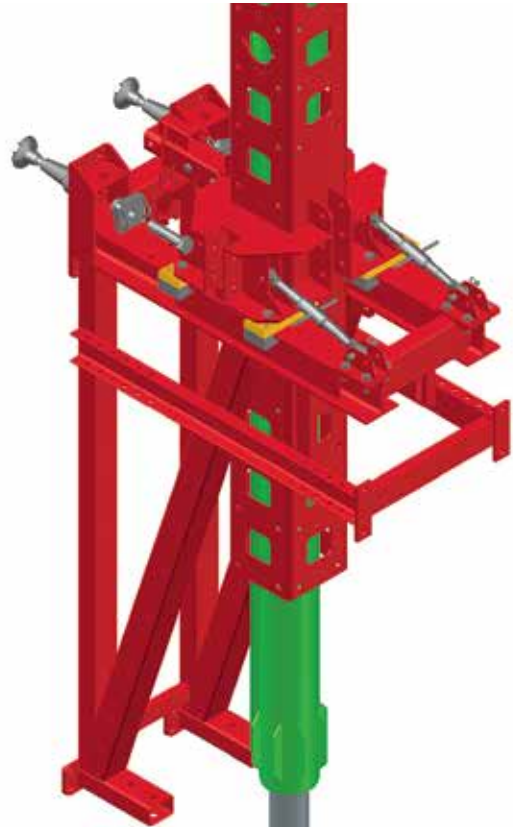

Lifting Cylinder



Climbing Bracket

Only one pair of ties per anchor position is required for anchoring the working and climbing brackets.

Tie DW 26
Threaded Anchor Plate DW 26
 (lost components)



Heavy-Duty Cone
M36/DW26-Ø108



Anchor Sliding Piece
ACS-C M36/12



Bolt ISO 4014
M36x160-10.9



Recovering Tool SW 36



Fixing the Leading Anchor

Leading anchors are fixed to the formlining by means of hexagonal screws while a steel plate reinforces the mounting. This means that any movement during concreting is avoided. In order to transfer the high forces into the concrete, additional reinforcement must be arranged in the wall in the area of the climbing anchors; minimum wall thickness is 30 cm.

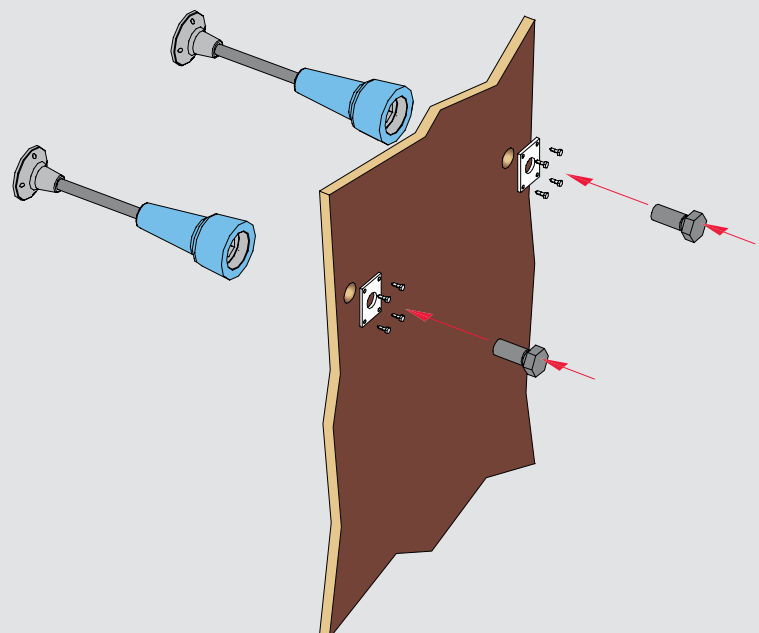

Fast and safe climbing in one lift

Synchronous climbing without any leading edges featuring an innovative hydraulic system

ACS Core 400 uses a climbing hydraulic system with particularly high lifting power. The system also synchronously and continuously transports several adjacent sets of core formwork in one lift to the next floor – with a stroke speed of 20 cm per minute.

The long-stroke cylinder used can be extended up to 5.10 m and has a lifting power of 40 t. As a result, up to 4.88 m high concreting sections are possible with one stroke. The innovative hydraulic system ensures synchronous climbing also with long lifting ranges and very large load differences on the individual cylinders.

The climbing process is very simple and fast because the hydraulics lift the entire climbing unit directly to the next floor after striking has taken place. Due to the high climbing speed, the lifting procedure is completed after only 20 minutes for standard storey heights of 4 m.

At the same time, the climbing process significantly increases work safety levels as the continuous climbing process of the entire core formwork means that there are never any leading edges. If required, the hydraulic pumps can be electronically coupled to each other and several sets of core formwork climbed synchronously.



The cylinder rod is bolted onto the lower yellow climbing bracket. The horizontal spacing between the cylinder and the wall varies; it can be adapted accordingly for retracting the formwork or climbing over offsets. If necessary, the hydraulic cylinders can be pulled up out of the Uprights and replaced without requiring any major modifications.



The hydraulic pump is positioned on the working platform (Level 0); depending on requirements, a 4-cylinder or a 6-cylinder pump is used. The hose connections are equipped with quick-release couplings; furthermore, the remote control has only three buttons which ensures simple and easy-to-understand use.



The hydraulic cylinders are arranged in a space-saving manner in the vertical Uprights which creates maximum available space in the working areas. The top end of the cylinder is located in the Upright and can be bolted on here in different positions. VARIOKIT struts and bracing with Tie Rods DW 15 provide the required reinforcement for the steel construction.

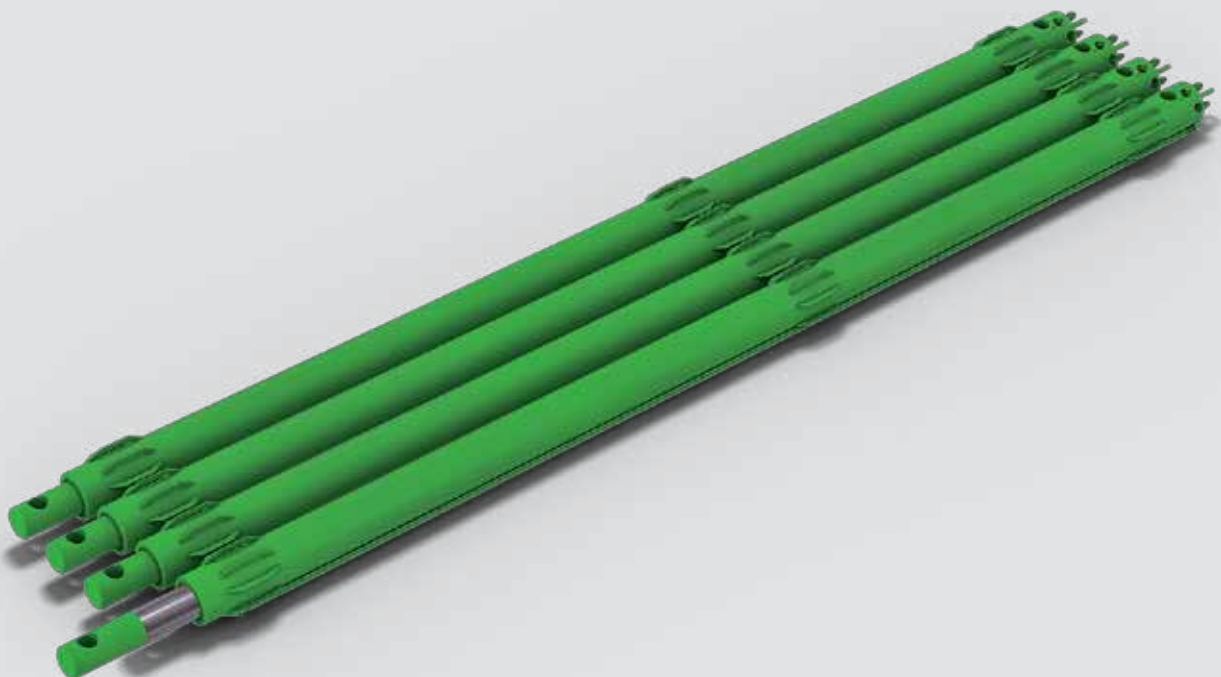

ACS Core 400 at a glance

The construction of the self-climbing system

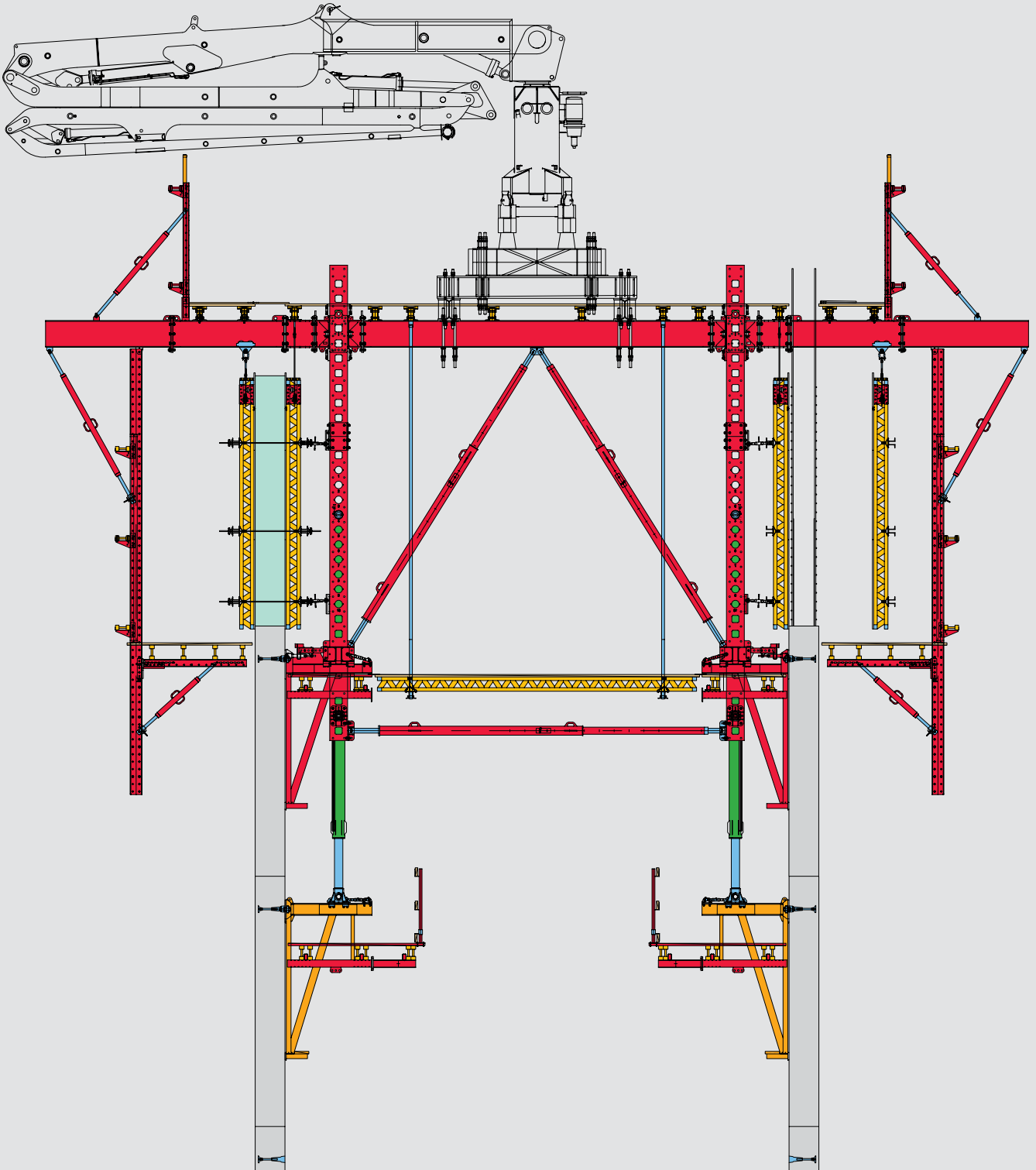

The ACS Core 400 climbing procedure

Starting position

- Working and climbing brackets are in the concreting position.

Preparation of the climbing procedure

- Striking takes place after the concrete has hardened whereby the external formwork is retracted.
- By extending the hydraulic cylinders until the bottom bolts are fully loaded, the working bracket is then load-free and raised by approx. 5 mm.
- Release the bolts and Anchor Sliding Piece, the working bracket is moved away from the wall by 2 cm.

Climbing the working bracket

- The lifting cylinder is extended and raises the upper construction with Level +1 and Level 0 with 0.2 m / min up to the next climbing anchor.
- During the lifting procedure, the oil flow control ensures synchronous climbing.

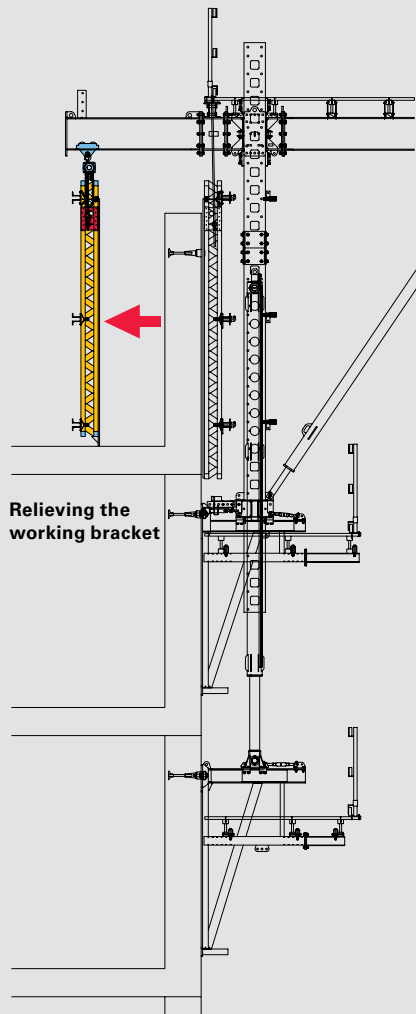
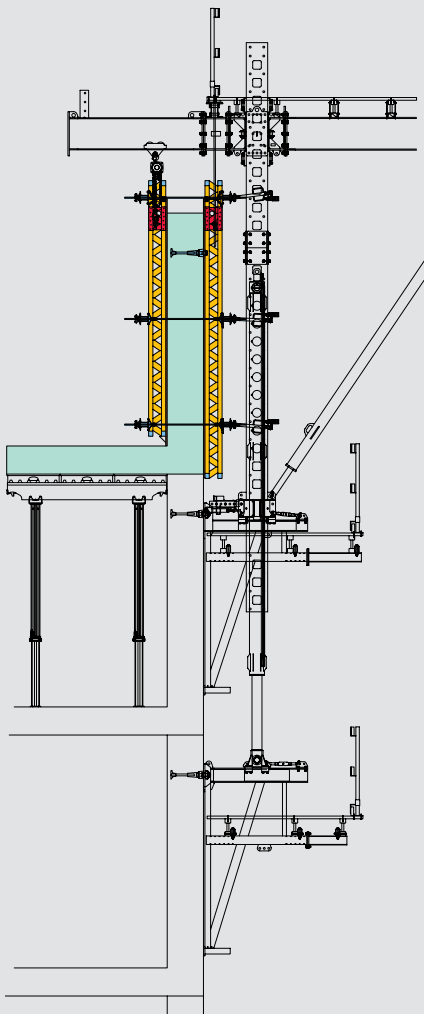

Relieving the working bracket

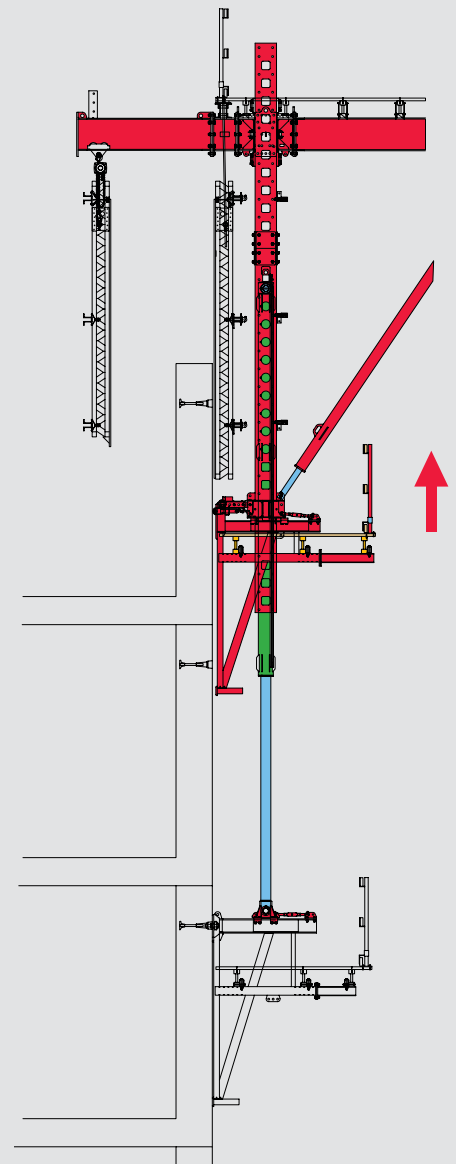

Mounting the working bracket

- The working bracket is suspended in the top climbing anchor and fixed in position here with an Anchor Sliding piece and bolt.
- The climbing bracket is relieved through a minimum extension of the cylinder, the heavy-duty anchors are removed.

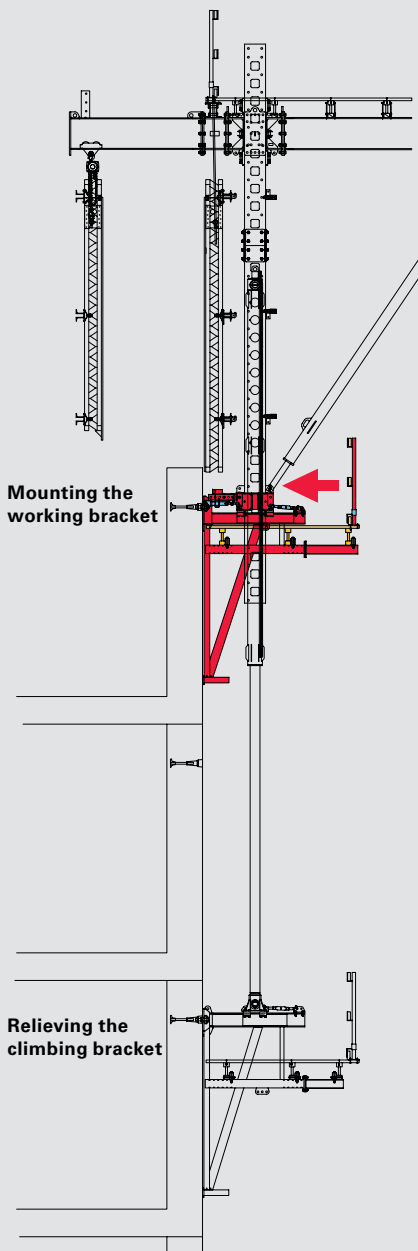

Climbing the climbing bracket

- By retracting the cylinder, the climbing bracket is raised to the next higher climbing anchors.

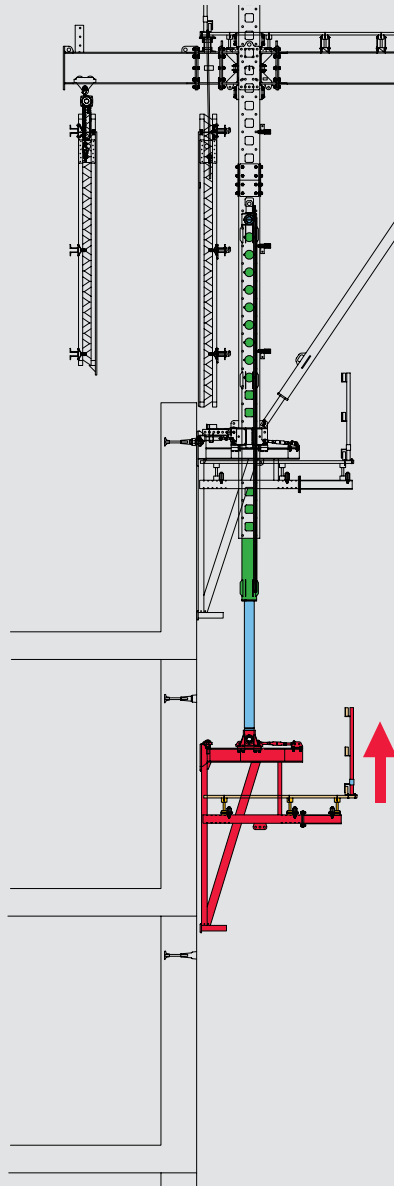

Completing the climbing procedure

- The climbing bracket is set down on the Anchor Sliding Pieces and fixed together with the climbing anchors.
- Additional minimal extension of the cylinders relieve the climbing brackets.
- External and internal formwork are positioned for the next concreting operations.

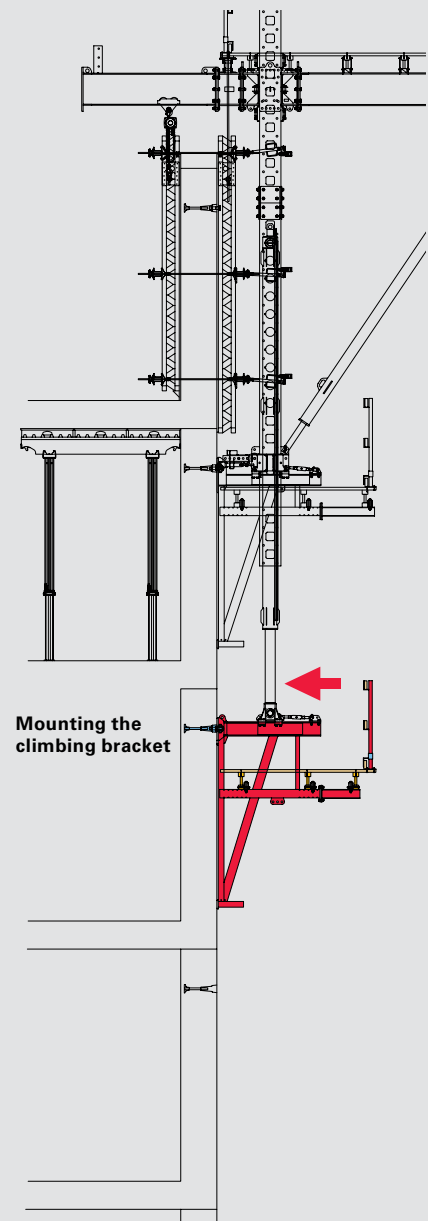

Suspension and support of the wall formwork, guardrails, positioning of the placing boom

Suspension of the wall formwork

The external formwork (left) is suspended on a trolley with an integrated chain hoist. After installing the slab reinforcement, the wall formwork can be lowered using this chain hoist if the wall and ceiling are concreted in one pour.

Suspension of the internal formwork (right) can be height adjusted by means of the threaded nut underneath the cross tube.

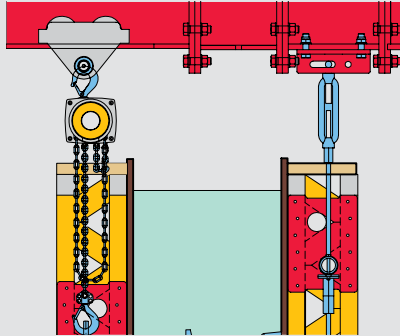

Aligning and supporting the wall formwork

Horizontally, the wall formwork rests against the Upright which encloses the hydraulic posts.

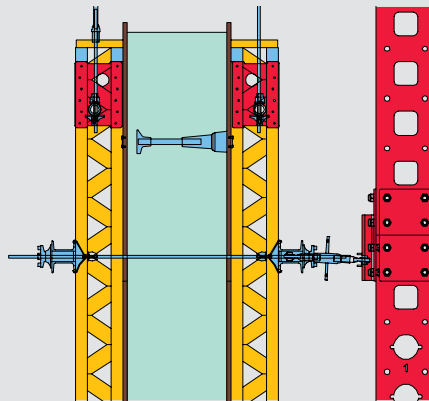

Guiding the climbing procedure

Rollers, which are supported against the concrete, guide the system during climbing. In operation, the steel plate is pressed against the wall by means of spindles.



High level of safety on the working platform with LPS Screen

Lightweight, 200 cm high PERI LPS Mesh Panels can be used to secure the leading edge on the outer working platform.

Thanks to the construction in the form of a permeable mesh panel, LPS is the lightweight alternative to enclosed protection panel systems. Furthermore, the load on the structure is reduced due to the low weight.

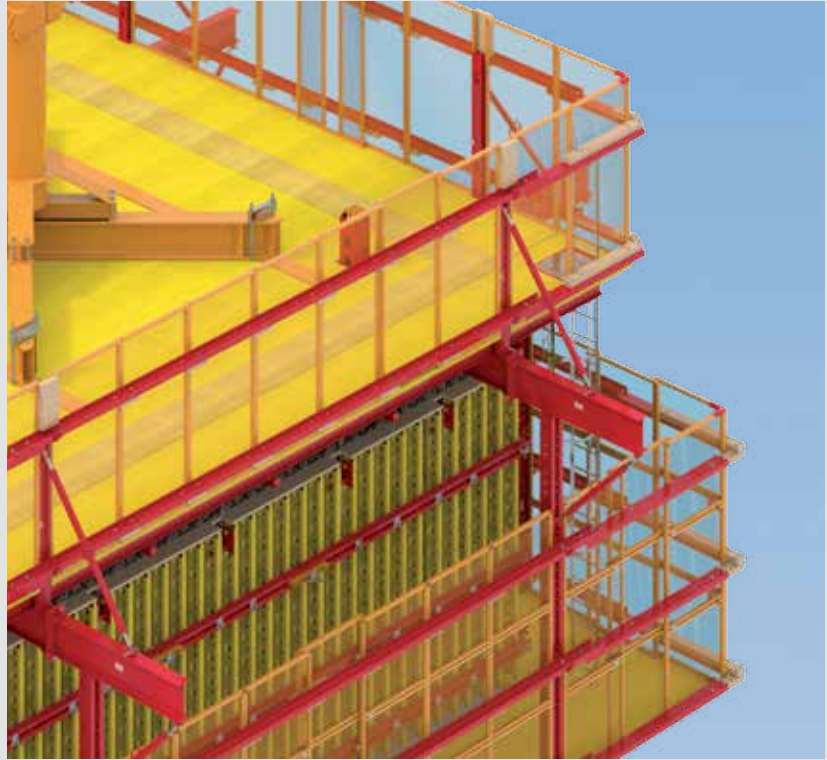

Positioning of the placing boom

The placing boom is positioned on Level +1. The required support construction is executed depending on the size of the placing boom which has been configured according to project specifications.



Fast striking



For a easy and simple striking procedure, use the VARIO GT 24 Shaft Corner, or TRIO or MAXIMO shaft elements. Alternatively, a hydraulic solution facilitates faster striking with even more reduced workload.

Striling with the VARIO Shaft Corner

The VARIO Shaft Corner ensures fast striking operations and moving the internal formwork in one working step. Time-consuming dismantling and re-assembly of individual formwork segments are no longer necessary.

A compensation area is arranged on each side of the formwork while a flexi-

ble Striking Corner Profile is positioned in every shaft corner. When forcing the formwork away from the concrete in the compensation areas and pulling together the L-shaped formwork segments (wall centre – corner – wall centre), the entire shaft formwork is moved approx. 2 cm off the wall. The complete shaft internal formwork can then be moved in one crane lift.



Striking with hydraulic support

As an option, the suspended internal formwork can be equipped with a hydraulic solution for ensuring fast striking operations. For this, a hydraulic cylinder is installed for each waler line. The hose connections are connected to the AUX connection of the hydraulic pump. At the touch of a button, the entire shaft formwork is thus struck very quickly.

When widening the core formwork, the hydraulics move the formwork against a pre-set limit stop so that the previously specified dimension is reached without any additional effort.

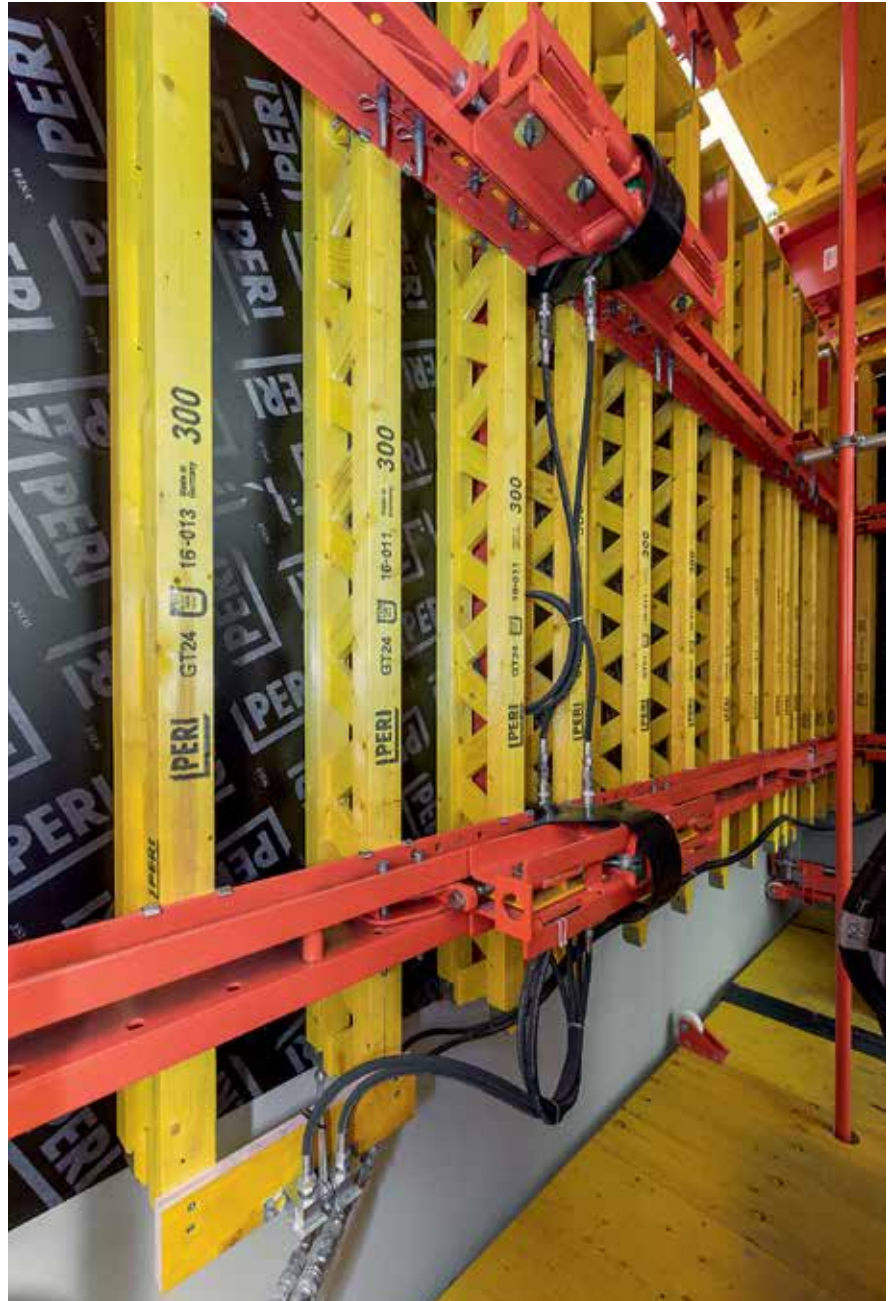

PERI services for the best results

From the initial consultation session through to the last return delivery of materials – PERI offers the best possible support throughout the project





In numerous projects world-wide, PERI has proved its superb problem-solving competence and high level of customer orientation time and time again. PERI customers can rely on a comprehensive range of engineering and service solutions.

Frequently, high-rise buildings are uniquely designed whereby a wide range of challenges have to be solved during their construction as well as having to meet diverse requirements. PERI Engineering can refer to its special expertise in the planning process and project management of climbing solutions. The focus of all PERI activities is always on providing the most cost-effective project solution along with collaborative partnerships with customers throughout the whole of the project.

Customer-specific solutions – implemented in partnership



PERI engineers provide valuable advice and support for realizing all high structures; they plan and dimension climbing formwork solutions in order to meet any architectural challenge. Taking into account the technical requirements, framework conditions during the execution together with individual customer requirements, optimized solutions are created for each project task – and this often during the tender phase.

Over the past decades, PERI has demonstrated through numerous high-rise buildings, towers, pylons and other high structures what is feasible and in which way climbing solutions can be efficiently and cost-effectively implemented – no matter in what form and regardless of the height. Goal of PERI engineers is always ensuring process optimization with the objective of reducing both execution times and costs.



PERI services: technical processing

Individual planning and advice as well as customized solutions from formwork and scaffolding experts.

Over 1,200 PERI engineers at around 180 locations worldwide work closely together with customers in order to develop the most suitable climbing formwork solution. This results in detailed plans and very accurate parts lists for the execution. The project-specific assembly plans comprehensively support the correct installation on site; likewise, the technical documentation provided each time. In addition, PERI carries out the project-related structural calculations and, if necessary, also as verifiable static calculations.

Your benefits

Optimized solutions

with project-specific planning including site-compliant drawings and parts lists

No interface-related loss

through continuous project support and technical advice from a PERI specialist – if required, also directly on the jobsite

Planning reliability

through regulation-compliant or verifiable static calculations



- 2D and 3D planning: ground plans, sections and details for cost-effective, safe and correct use of PERI products and systems on the construction site
- Operational and cycle planning: drawings for standard and special uses including the mapping of the processes; concrete cycle planning for optimal utilization of the products used
- Assembly plans: project-specific planning for supporting the professional assembly of special solutions
- Informal structural calculations: project-related static for a stable and reliable planning process
- Verifiable static calculations: static proof of a formwork and scaffolding construction for distribution to an external inspection engineer

PERI services: formwork assembly

From cut-to-size plywood panels through to 3D elements – customized for every project requirement

PERI produces cut-to-size plywood panels and special formwork of all kinds – from simple formats and box outs to 3D formwork units for once-only applications. All customized elements are produced in the clearly defined quality and appropriate for the planned number of uses

Your benefits

Perfectly assembled

for the individual component or structural shapes

With high quality

executed by well-trained skilled staff in modern prefabrication facilities using the very latest machine technology

Just-in-time deliveries

assembled and delivered to the construction site on-time and according to the construction progress



- CNC cut-to-size plywood panels in any geometric shape and formwork units made of panel materials according to customer requirements
- Assembly of straight or curved VARIO special formwork for complex wall elements
- 2D or 3D additional infill spaces as well as complex formwork units according to individual requirements regarding shape, type of formlining and planned number of uses
- Pre-assembly of climbing units in transportable dimensions which can be quickly and easily assembled on the jobsite

PERI services: project management

Professional on-site support provided by supervisors and PERI project managers

Construction teams are provided with comprehensive on-site support by PERI supervisors to ensure efficient use of PERI systems from the beginning onwards. If required, a PERI project manager can also be appointed for large jobsites who helps, in close coordination with the site management, to continually adapt the amount of materials to suit the actual construction progress. The project manager thereby helps to further optimize material requirements and costs throughout the construction sequence.

Your benefits

Professional on-site briefings

through experienced PERI supervisors

Increasing the cost-efficiency

by means of individual on-site project management

Continuous cost control

through target/actual performance comparisons for the continuous monitoring of material, time and costs

Transparency and planning reliability

thanks to site-compliant and comprehensible methods of payments



PERI supervisor

- Briefings for the operation and handling of PERI formwork and scaffolding systems
- Explanation of plans and parts lists
- Information on the maintenance, cleaning and storage of PERI formwork and scaffolding systems

PERI project manager

- Planning, delivery and optimization of cost-effective material use
- Organization and coordination of the formwork and scaffolding planning
- Supervising the on-schedule provision of materials
- Coordinating the movement of materials on the construction site
- Organizing the return delivery processes
- Compiling key figure reports on a weekly and monthly basis

ACS Core 400 in use

Reference projects with the core self-climbing formwork

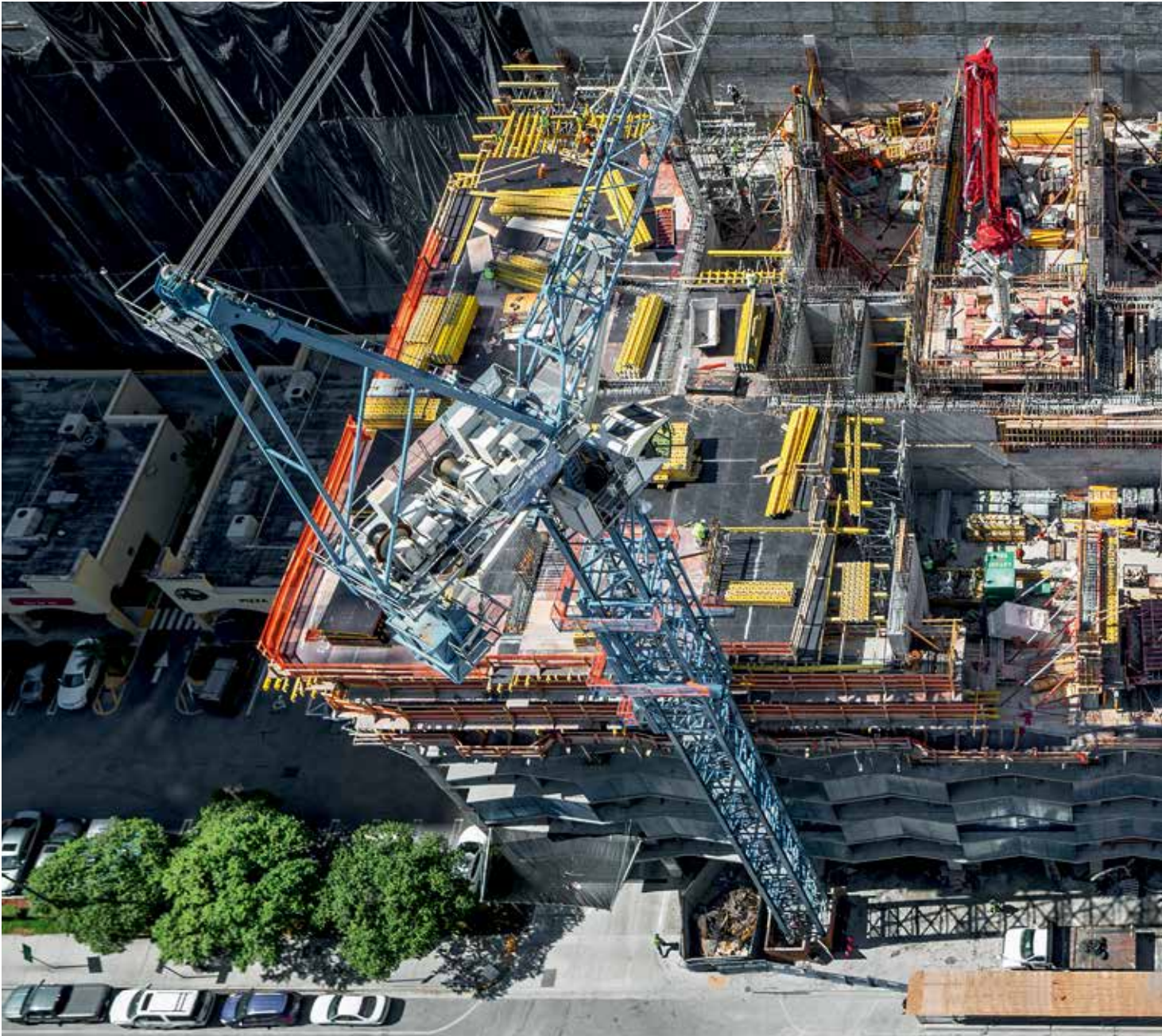

Solitair Brickell, Miami, Florida, United States

The Solitair Brickell was constructed in the Brickell district of Miami. The residential tower has a total of 48 floors including seven underground parking levels. With the ACS Core 400 climbing formwork, the construction team achieved short cycle times and maximum crane independence.



On the following pages, we show some reference projects where different variants of the ACS Core 400 self-climbing formwork were used.

ACS Core 400 in use

Reference projects with the core self-climbing formwork



The PERI ACS Core 400 self-climbing formwork shortened the cycle times for the construction of this 31-storey high-rise building.



The ACS Core 400 ensured that the construction team was able to meet the extremely tight schedule.

CEB Tower at Rosslyn Central Place, Arlington, Virginia, United States

The CEB Tower with 31 floors was built over the Rosslyn Metro Station very close to the Potomac River in Washington, D.C.C. After completion, the 120 m high public office building will be the tallest structure in the metropolitan region and will offer an exceptional view of the area thanks to a public viewing platform.

Altogether, the team from Clark Concrete realized around 2,500 m² (27,000 ft²) of 25 cm thick reinforced concrete slabs featuring unstressed as well as additional prestressed reinforcement. The top slab, which later forms the viewing platform at the top of the tower, is 45 cm thick.

With the ACS Core 400 self-climbing formwork, the construction team was able to simultaneously construct the elevator walls of the north and south sides – without having to rely on the only available tower crane. In the process, the walls were concreted at the same time as the slabs by means of a large placing boom. In this way, the cycle times for each floor were shortened by at least one day.

Solitaire Brickell, Miami, Florida, United States

The 48-storey residential tower, built in Miami's flourishing Brickell neighborhood, includes seven parking levels, around 4,500 square feet of retail space on the ground floor as well as more than 400 luxurious residential units. Designed by the architect Jonathan Cardello of ADD, the distinctive design complete with zig-zag balconies resembles that of a palm tree.

Using the ACS Core 400 climbing system, Baker Concrete Construction could achieve fast cycle times – without being dependent on the available jobsite crane. The especially powerful long-stroke cylinders of the self-climbing formwork synchronously lifted the complete core formwork up to the next level in each case. The formwork was thus climbed in a single lift and raised from one storey to the next without requiring any time-consuming intermediate climbing steps.

The construction team confirmed the reliability and easy handling of the PERI climbing formwork. The project manager described the ACS Core 400 as a key component in the reduction of the crane time.



Tower ICE with 66 floors was built in the Ice District in Edmonton whereby the building core is being realized with the ACS Core 400

ICE District Stantec Tower, Edmonton, Canada

Completion of the 250 m high Tower E, also known as Stantec Tower, is planned for 2019. Subsequently, the 66-storey tower will be the tallest building in Edmonton – and also the tallest building in Canada outside of Toronto. In the 10-hectare city district, many striking buildings have been built including a stadium and a cinema complex.

The ACS Core 400 is being used for the walls of the three-piece building core with axial dimensions of around 27.50 m x 13.50 m. In the course of construction progress, one RCS Climbing Protection Panel will subsequently be used to enclose the storeys of the building shell and providing anti-fall protection. SKYDECK and SKYTABLE are used as slab formwork while a large part of the walls are formed using the tried and tested TRIO Panel Formwork.



Integrated roofing for the climbing formwork accelerated the installation of the elevators by almost one year.

8th and Howell Hotel, Seattle, Washington, United States

The 8th and Howell Hotel is one of the largest construction projects Seattle has ever seen. After completion in 2018, it will be the largest hotel in Seattle featuring 48 floors and offering 1.4 million m² of usable floor space; it is located very close to the Washington State Convention Center.

PERI delivered three sets of ACS Core 400 climbing units for the realization of the three massive reinforced concrete shafts which form the 10.65 m x 27.40 m reinforced concrete core. In this case, the climbing solution is combined with the MAXIMO Panel Formwork which is characterized by the one-sided tie technology.

In addition, PERI engineers planned a construction comprised of VARIOKIT system components that were used to provide roofing for the elevator shafts during the entire construction and keep them dry. Thus, installation of the elevators could be carried out immediately after formworking operations. The pre-fabricated rebar cages for the walls were lowered directly into the wall formwork by means of integrated, hydraulically operated flaps in the VARIOKIT construction.

PERI International

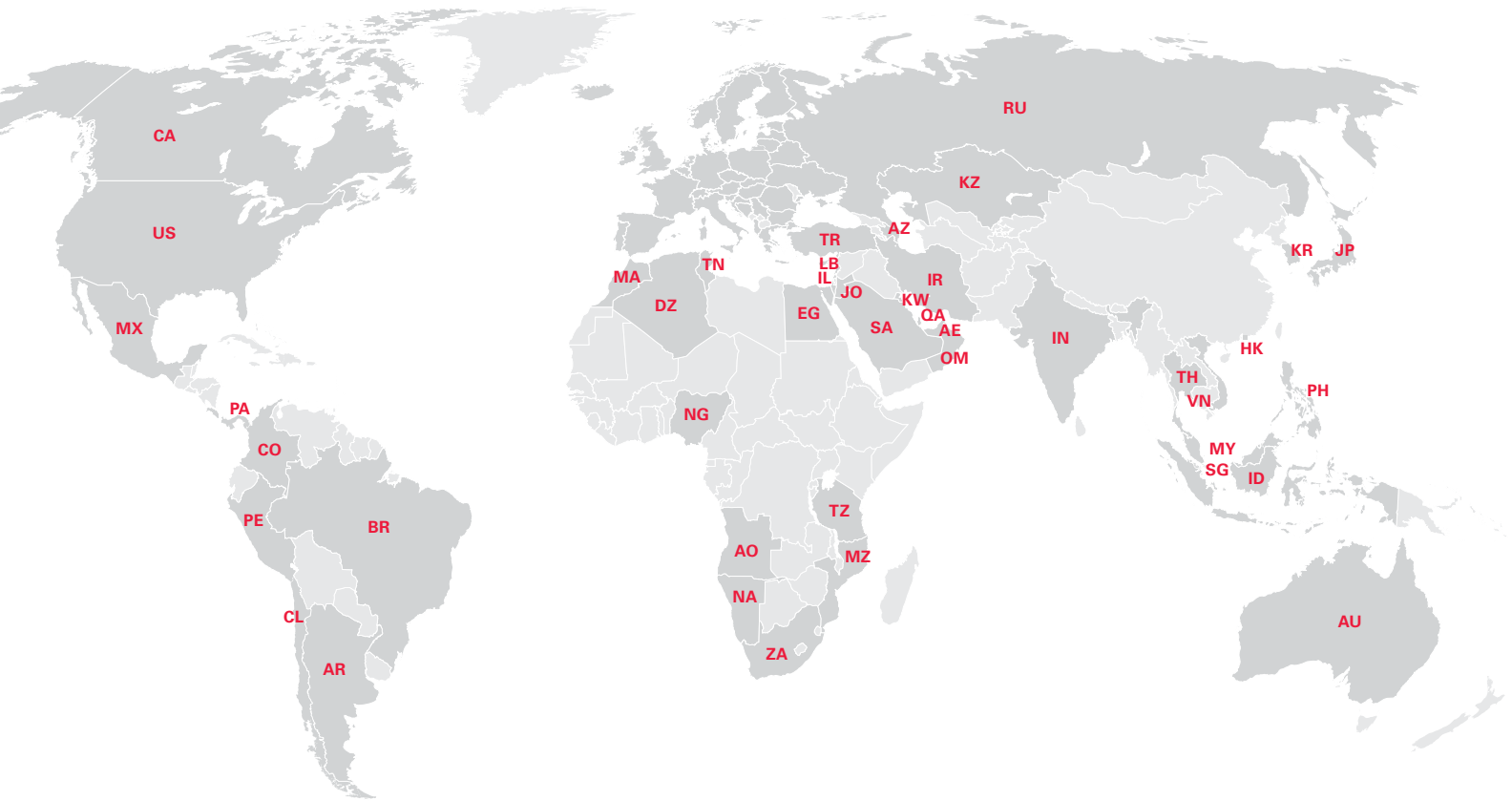

North America

- CA** Canada
PERI Formwork Systems, Inc.
www.peri.ca
- MX** Mexico
PERI Cimbras y Andamios, S.A. de C.V.
www.peri.com.mx
- PA** Panama
PERI Panama Inc.
www.peri.com.pa
- US** USA
PERI Formwork Systems, Inc.
www.peri-usa.com

South America

- AR** Argentina
PERI S.A.
www.peri.com.ar
- BR** Brazil
PERI Formas e Escoramentos Ltda.
www.peribrasil.com.br
- CL** Chile
PERI Chile Ltda.
www.peri.cl
- CO** Colombia
PERI S.A.S.
www.peri.com.co
- PE** Peru
PERI Peruana S.A.C.
www.peri.com.pe

Africa

- AO** Angola
Pericofragens, Lda.
www.peri.pt
- DZ** Algeria
S.A.R.L. PERI
www.peri.dz
- EG** Egypt
Egypt Branch Office
www.peri.com.eg
- MA** Morocco
PERI S.A.
www.peri.ma
- MZ** Mozambique
PERI (Pty.) Ltd.
www.peri.co.mz
- NA** Namibia
PERI (Pty.) Ltd.
www.peri.na
- NG** Nigeria
PERI Nigeria Ltd.
www.peri.ng
- TN** Tunisia
PERI S.A.U.
www.peri.es
- TZ** Tanzania
PERI Formwork and Scaffolding Ltd
www.peri.co.tz
- ZA** South Africa
PERI Formwork Scaffolding (Pty) Ltd
www.peri.co.za

Asia

- AE** United Arab Emirates
PERI (L.L.C.)
www.peri.ae
- AZ** Azerbaijan
PERI Representative Office
www.peri.com.tr
- HK** Hong Kong
PERI (Hong Kong) Limited
www.perihk.com
- ID** Indonesia
PT Beton Perkasa Wijaksana
www.betonperkasa.com
- IL** Israel
PERI F.E. Ltd.
www.peri.co.il
- IN** India
PERI (India) Pvt Ltd
www.peri.in
- IR** Iran
PERI Pars. Ltd.
www.peri.ir
- JO** Jordan
PERI GmbH – Jordan
www.peri.com
- JP** Japan
PERI Japan K.K.
www.peri.co.jp
- KR** Korea
PERI (Korea) Ltd.
www.perikorea.com
- KW** Kuwait
PERI Kuwait W.L.L.
www.peri.com.kw
- KZ** Kazakhstan
TOO PERI Kazakhstan
www.peri.kz
- LB** Lebanon
PERI Lebanon Sarl
lebanon@peri.de
- MY** Malaysia
PERI Formwork Malaysia Sdn. Bhd.
www.perimalaysia.com
- OM** Oman
PERI (L.L.C.)
www.peri.ae
- PH** Philippines
PERI-Asia Philippines, INC.
www.peri.com.ph
- QA** Qatar
PERI Qatar LLC
www.peri.qa
- SA** Saudi Arabia
PERI Saudi Arabia Ltd.
www.peri.com.sa
- SG** Singapore
PERI Asia Pte Ltd
www.periasia.com
- TH** Thailand
Peri (Thailand) Co., Ltd.
www.peri.co.th
- TR** Turkey
PERI Kalıp ve İskeleleri
www.peri.com.tr
- VN** Vietnam
PERI ASIA PTE LTD
www.peri.com.vn



PERI

PERI GmbH Formwork Scaffolding Engineering

Rudolf-Diesel-Strasse 19
89264 Weissenhorn
Germany
Tel. +49 (0)7309.950-0
Fax +49 (0)7309.951-0
info@peri.com
www.peri.com

Oceania

AU Australia
PERI Australia Pty. Ltd.
www.periaus.com.au

DK Denmark
PERI Danmark A/S
www.peri.dk

IT Italy
PERI S.r.l.
www.peri.it

SE Sweden
PERI Sverige AB
www.peri.se

Europe

EE Estonia
PERI AS
www.peri.ee

LT Lithuania
PERI UAB
www.peri.lt

SI Slovenia
PERI oplate i skele d.o.o
www.peri.com.hr

AL Albania
PERI Kalıp ve İskeleleri
www.peri.com.tr

ES Spain
PERI S.A.U.
www.peri.es

LU Luxembourg
N.V. PERI S.A.
www.peri.lu

SK Slovakia
PERI spol. s. r.o.
www.peri.sk

AT Austria
PERI Ges.mbh
www.peri.at

FI Finland
PERI Suomi Ltd. Oy
www.perisuomi.fi

LV Latvia
PERI SIA
www.peri-latvija.lv

UA Ukraine
TOW PERI
www.peri.ua

BA Bosnia and Herzegovina
PERI oplate i skele d.o.o
www.peri.com.hr

FR France
PERI S.A.S.
www.peri.fr

NL Netherlands
PERI b.v.
www.peri.nl

BE Belgium
PERI N.V.
www.peri.be

GB United Kingdom
PERI Ltd.
www.peri.ltd.uk

NO Norway
PERI Norge AS
www.peri.no

BG Bulgaria
PERI Bulgaria EOOD
www.peri.bg

GR Greece
PERI Hellas Ltd.
www.perihellas.gr

PL Poland
PERI Polska Sp. z o.o.
www.peri.com.pl

BY Belorussia
IOOO PERI
www.peri.by

HR Croatia
PERI oplate i skele d.o.o.
www.peri.com.hr

PT Portugal
Pericofragens Lda.
www.peri.pt

CH Switzerland
PERI AG
www.peri.ch

HU Hungary
PERI Kft.
www.peri.hu

RO Romania
PERI România SRL
www.peri.ro

CZ Czech Republic
PERI spol. s r.o.
www.peri.cz

IR Ireland
Siteserv Access & Formwork
www.siteservaccess.ie

RS Serbia
PERI oplate d.o.o.
www.peri.rs

DE Germany
PERI GmbH
www.peri.de

IS Iceland
Armar ehf.
www.armor.is

RU Russia
OOO PERI
www.peri.ru

**The optimal System
for every Project and
every Requirement**



Wall Formwork



Column Formwork



Slab Formwork



Climbing Systems



Bridge Formwork



Tunnel Formwork



Shoring Systems



Construction Scaffold



Facade Scaffold



Industrial Scaffold



Access



Protection Scaffold



Safety Systems



**System-Independent
Accessories**



Services



PERI GmbH
Formwork Scaffolding Engineering
 Rudolf-Diesel-Strasse 19
 89264 Weissenhorn
 Germany
 Tel. +49 (0)7309.950-0
 Fax +49 (0)7309.951-0
 info@peri.com
 www.peri.com

