

PERI UP Flex Shoring Tower

Instructions for Assembly and Use – Standard Configuration – Issue 02/2020
incl. supplemental pages PERI UP Flex 2nd generation

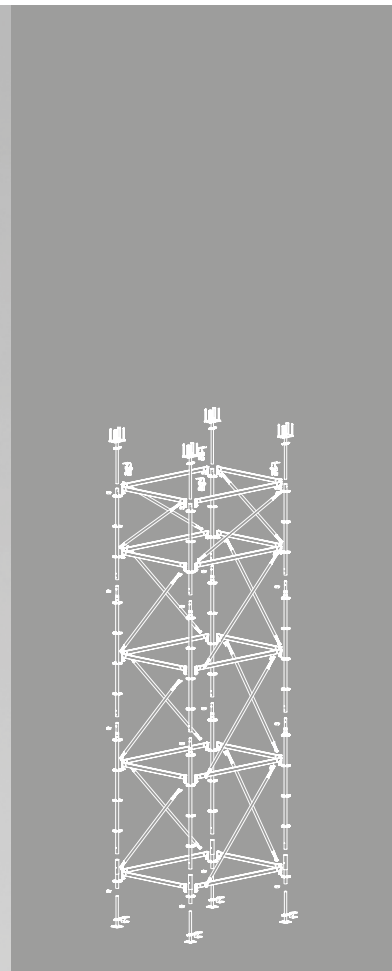
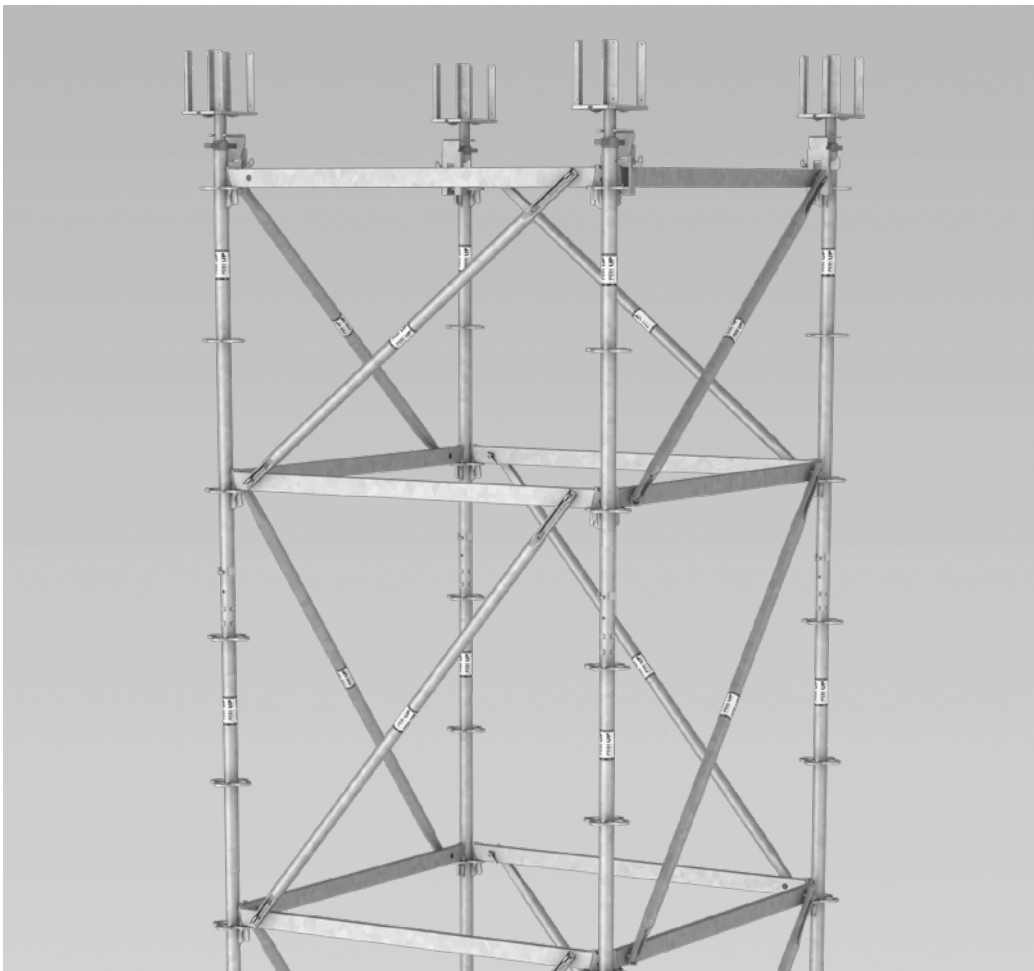

Overview

Main components

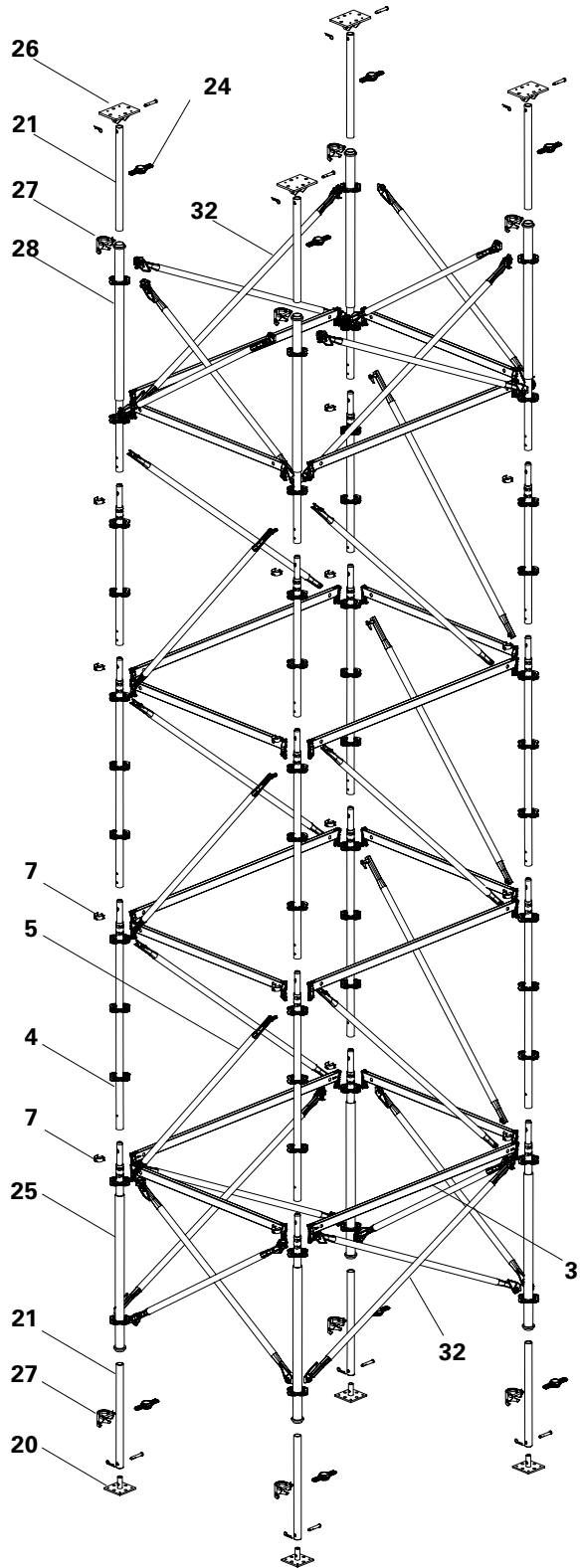
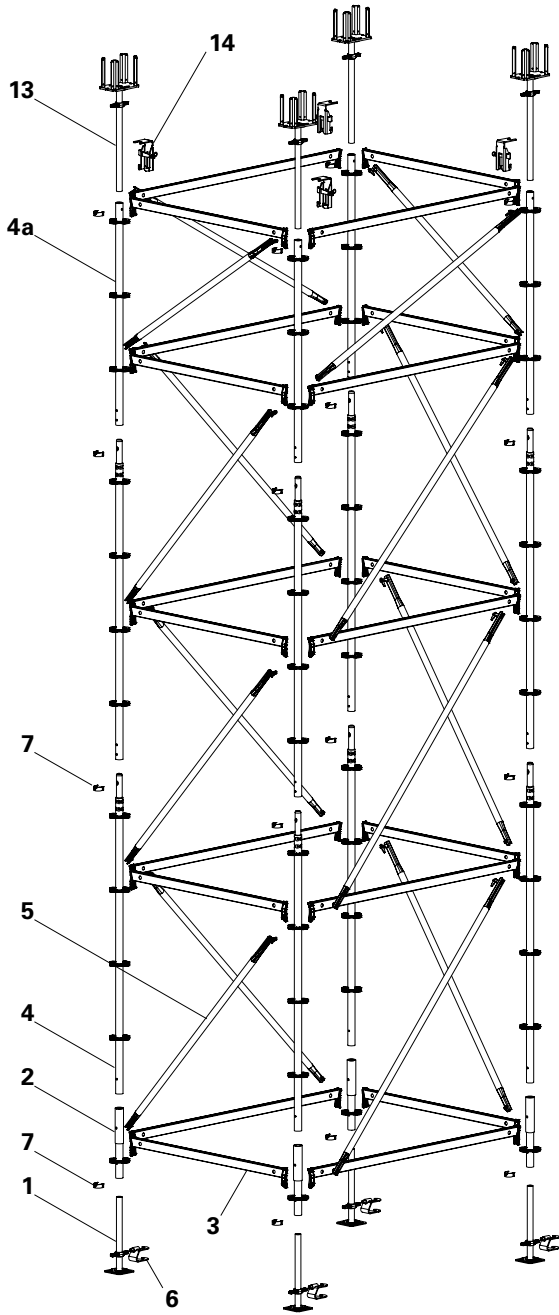

- | | | | | | |
|----|---------------------------|----|---|----|--|
| 1 | Adjustable Base Plate UJB | 6 | Spindle Locking UJS | 24 | Quick Jack Nut TR 48-2 |
| 2 | Base Standard UVB 24 | 7 | Locking Pin Ø 48/57 | 25 | Base Standard UVB 135 Plus |
| 3 | Ledger UH | 11 | Cross Forkhead TR 38-70/50 alternatively: Head Spindle | 26 | Head Plate for Spindle Tube TR 48 alternatively: Cross Head Spindle TR 48 |
| 4 | Standard UVR | 12 | Head Spindle Locking UJH | 27 | Spindle Locking UJS Plus |
| 4a | Top Standard UVH | 20 | Base Plate for Spindle Tube TR 48 | 28 | Top Standard UVH 165 Plus |
| 5 | Ledger Brace UBL | 21 | Spindle Tube TR 48 | 32 | Shoring Brace UBS |

Content

Overview

| | |
|--------------------------|---|
| Key | 2 |
| Presentational reference | 2 |

Introduction

| | |
|---------------------------------------|---|
| Target groups | 3 |
| Additional technical documentation | 3 |
| Intended use | 4 |
| Instructions for Use | 4 |
| Cleaning and maintenance instructions | 5 |

Safety instructions

| | |
|----------------------------|---|
| Cross-system | 6 |
| System-specific | 7 |
| Storage and transportation | 7 |

Safety during assembly

| | |
|---------------------------|---|
| Attachment points for PPE | 8 |
|---------------------------|---|

A1 PERI UP Flex Shoring Tower

| | |
|-------------------------|----|
| General | 10 |
| Base unit | 10 |
| Standards and ledgers | 11 |
| Height units | 12 |
| Top tower unit | 13 |
| Height adjustment | 14 |
| Erection with the crane | 14 |
| Dismantling | 15 |

A2 Additional Frames

| | |
|---------------------------|----|
| Layouts | 16 |
| General | 17 |
| Base Frame VSS | 17 |
| Standards and Ledgers VSS | 17 |
| Height Units VSS | 17 |
| Ledgers and Diagonals VSS | 18 |
| Head Element with | |
| Height Adjustment VSS | 18 |
| Erection with the crane | 19 |
| Dismantling | 20 |

A3 PERI UP Flex Shoring Tower Plus

| | |
|-------------------------|----|
| General | 22 |
| Preparation | 22 |
| Assembly | 25 |
| Erection with the crane | 28 |
| Dismantling | 29 |

A4 Support

| | |
|--------------------------------|----|
| Supporting individual towers | 30 |
| Bracing sets of shoring towers | 31 |

B1 System supplementation

| | |
|---|----|
| Tower with Section Spindles | 32 |
| Height extensions or reductions | 34 |
| Transportation Wheel UEW | 35 |
| Trolley with Winch | 37 |
| Inclined erection areas, inclined slab decks | 40 |

C Storage and transportation

42

D Design tables

| | |
|---------------------------------|----|
| PERI UP Flex Shoring Tower | 44 |
| PERI UP Flex Shoring Tower Plus | 48 |

Components

| | |
|------------|----|
| Components | 52 |
|------------|----|

Supplemental pages PERI UP Flex 2nd generation I-IV

Key

Pictogram | Definition

 Safety instructions

 Note

 Load-bearing point

 Visual check

 Tip

 Misapplication

Dimension specifications

Dimensions are usually given in cm. Other units of measure, e.g. m, are shown in the illustrations.

Conventions

- Instructions are numbered with:
1., 2., 3.
- The result of an instruction is shown by: →
- Position numbers are clearly provided for the individual components and are given in the drawing, e.g. **1**, in the text in brackets, for example (1).
- Multiple position numbers, i.e. alternative components, are represented with a slash, e.g. **1 / 2**.

Arrows

- ➔ Arrow representing an action
- ⇨ Reaction arrow representing an action
- Forces

Presentational reference

The illustration on the front cover of these instructions is understood to be a system representation only. The assembly steps presented in these Instructions for Assembly and Use are shown in the form of examples with only one component size. They are correspondingly valid for all component sizes contained in the standard configuration.

For a better understanding, detailed illustrations are partly incomplete. The safety installations which have possibly not been featured in these detailed drawings must nevertheless still be available.

Target groups

Contractors

These Instructions for Assembly and Use are designed for contractors who use the scaffolding either for

- assembling, modifying and dismantling, or use
- it e.g. for concreting or
- who have it used, e.g. for forming operations.

Competent person

(Construction Site Coordinator)

The Safety and Health Coordinator*

- is appointed by the client,
- must identify potential hazards during the planning phase,
- determines measures that provide protection against risks,
- creates a safety and health plan,
- coordinates the protective measures for the contractor and site personnel so that they do not endanger each other,
- monitors compliance with the protective measures.

Competent person qualified to carry out inspections

Due to the specialist knowledge gained from professional training, work experience and recent professional activity, the competent person has a reliable understanding of safety-related issues and can correctly carry out inspections. Depending on the complexity of the test to be undertaken, e.g. scope of testing, type of testing or the use of a certain measuring device, a range of specialist knowledge is necessary.

Qualified persons

The scaffolding may only be assembled, modified or dismantled by personnel who are suitably qualified to do so.

For the work to be carried out, the qualified persons must have received instructions** which contain at least the following points:

- An explanation of the plan for the assembly, modification or dismantling of the scaffolding in an understandable form and language.
- Description of the measures in order to safely assemble, modify or dismantle the scaffolding.

- Designation of the preventive measures to avoid the risk of persons and objects falling.
- Designation of the safety precautions in the event of changing weather conditions which could adversely affect the safety of the scaffolding as well as the personnel concerned.
- Details regarding the permissible loads.
- Description of any other risks that are associated with the assembly, modification or dismantling procedures.



- **In other countries, ensure that the relevant national guidelines and regulations in the respective current version are complied with!**
- **If no country-specific regulations are available, it is recommended to proceed according to German rules and regulations.**
- **A competent person must be present on site during scaffolding work.**

* Valid in Germany: Regulations for Occupational Health and Safety on Construction Sites 30 (RAB 30).

** Instructions are given by the contractor himself or a competent person selected by him.

Additional technical documentation

- Type Test No. S/N 030340
- Instructions for Use
 - Trolley with Winch
 - Pallets and Stacking Devices
- Data Sheet for Anchor Bolt PERI 14/20 x 130
- PERI Design Tables – Formwork and Shoring
- Design Tables – PERI UP Flex

Intended use

Product description

PERI products have been designed for exclusive use in the industrial and commercial sectors by qualified personnel only.

The PERI UP Flex Shoring Tower allows a large range of project-specific application possibilities. As a result of the building-specific risk assessment, there are also other possibilities of ensuring assembly reliability and working safety with the help of components from the PERI UP Scaffolding Kit, e.g. decks, hatches, stairs.

Features

The PERI UP Flex Shoring Tower is used in shoring constructions in a systematic vertical position for transferring vertical and, in part, horizontal loads. All components are galvanized. The main feature of the PERI UP Flex Shoring Tower is the particularly rigid node connection between the rosettes of the standards and the ledgers.

For erecting the shoring towers, individual standards are connected with ledgers which are particularly easy to assemble due to the wedge connections. Bracing is installed in the form of system diagonals.

Through the combination of standards with lengths of $L = 2.0$ m and top standards of varying lengths, all heights can be continuously achieved.

Shoring tower dimensions

Assembly of the shoring tower is shown using the dimensions 2.00×1.50 m as an example. The following dimensions are possible:

Longitudinal direction: $1.00 / 1.50 / 2.00 / 2.50 / 3.00$ m.

Lateral direction:

$1.00 / 1.50 / 2.00 / 2.50 / 3.00$ m

Any combination is allowed.

System dimensions

PERI UP Flex Shoring Tower

Type-tested assembly heights as free-standing individual towers up to 8.39 m: restrained at the top up to 21.89 m (22.34 m with spindle section) for ground plans with 1.50×1.50 m and more.

PERI UP Flex Shoring Tower with Additional Frame (VSS)

Assembly heights 1.33 m to 21.89 m.

PERI UP Flex Shoring Tower Plus

Adj. Base Plate TR 48, Head Spindle TR 48 up to 15.58 m.

Adj. Base Plate and Head Spindle TR 48 up to 16.26 m.

Technical data

Permissible load-bearing capacities: see type tests and PERI design tables.

PERI UP Flex Shoring Towers correspond to Rating Class B1 in accordance with DIN EN 12812.

Instructions for use

The use in a way not intended, deviating from the standard configuration or the intended use according to the Instructions for Assembly and Use, represents a misapplication with a potential safety risk, e.g. risk of falling.

Deviations from the standard configuration for each individual application must be verified by means of separate strength and stability calculations (Industrial Safety Regulation Appendix 1, No. 3.2.1) and explicitly reflected in the assembly instructions.

Only original PERI scaffolding components may be used.

The use of other products and spare parts is not allowed.

Changes to PERI components are not permitted.

Cleaning and maintenance instructions

In order to maintain the value and operational readiness of the PERI products over the long term, clean the elements after each use.

Some repair work may also be inevitable due to the tough working conditions. The following points should help to keep cleaning and maintenance costs as low as possible.

Do not clean powder-coated or galvanized components with steel brushes or metal scrapers.

Mechanical components, e.g. spindles, must be cleaned of dirt or concrete residue before and after use.

Provide suitable support for the components during cleaning so that no unintentional change in their position is possible.

Do not clean components suspended on a crane.

Any repairs to PERI products are to be carried out by PERI qualified personnel only.

Cross-system

General

The contractor must ensure that the Instructions for Assembly and Use supplied by PERI are available at all times and understood by the site personnel.

These Instructions for Assembly and Use can be used as the basis for creating a risk assessment. The risk assessment is compiled by the contractor. These Instructions for Assembly and Use do not replace the risk assessment!

Always take into consideration and comply with the safety instructions and permissible loads.

For the application and inspection of PERI products, the current safety regulations and guidelines must be observed in the respective countries where they are being used.

Materials and working areas are to be inspected on a regular basis, especially before each use and assembly, for:

- signs of damage,
- stability and
- function.

Damaged components must be exchanged immediately on site and may no longer be used.

Safety components are to be removed only when they are no longer required.

Components provided by the contractor must conform with the characteristics required in these Instructions for Assembly and Use as well as all valid construction guidelines and standards. Unless otherwise indicated, this applies in particular to:

- Timber components: Strength Class C24 for Solid Wood according to EN 338.
- Scaffold tubes: galvanised steel tubes with minimum dimensions of $\text{Ø } 48.3 \times 3.2$ mm according to EN 12811-1:2003 4.2.1.2.
- Scaffold tube couplings according to EN 74.

Deviations from the standard configuration are only permitted after a further risk assessment has been carried out by the contractor.

On the basis of this risk assessment, appropriate measures for working and operational safety as well as stability are to be determined.

Corresponding proof of stability can be provided by PERI on request if the risk assessment and resulting measures to be implemented are made available.

Before and after exceptional occurrences that may have an adverse effect regarding the safety of the scaffolding system, the contractor must immediately

- create an additional risk assessment, with appropriate measures for ensuring the stability of the formwork system being carried out based on the results,
- and arrange for an extraordinary inspection by a competent person. The aim of this inspection is to identify and rectify any damage in good time in order to guarantee the safe use of the scaffolding system.

Exceptional occurrences can include:

- accidents,
- longer periods of non-use,
- natural events, e.g. heavy rainfall, icing, heavy snowfall, storms or earthquakes.

Assembly, modification and dismantling work

Assembly, modification or dismantling of scaffolding systems may only be carried out by qualified persons and under the supervision of a competent person. The qualified persons must have received appropriate training for the work to be carried out with regard to specific risks and dangers.

On the basis of the risk assessment and Instructions for Assembly and Use, the contractor must create installation instructions in order to ensure safe assembly, modification and dismantling of the scaffolding system.

Before initial use, the safe functioning of the scaffold must be checked by a person qualified to carry out the inspection. The result of the inspection must be documented in an inspection record.

The contractor must ensure that the personal protective equipment required for the assembly, modification or dismantling of the system, e.g.

- safety helmet,
 - safety shoes,
 - safety gloves,
 - safety glasses,
- is available and used as intended.

If personal protective equipment against falling (PPE) is required or specified in local regulations, the contractor must determine appropriate attachment points on the basis of the risk assessment.

The personal protective equipment against falling to be used is determined by the contractor.

The contractor must

- provide safe working areas for site personnel which are to be reached through the provision of safe access ways. Areas of risk must be cordoned off and clearly marked.
- ensure the stability during all stages of construction, in particular during assembly, modification and dismantling operations.
- ensure and prove that all loads can be safely transferred.

Utilization

Every contractor who uses or allows the scaffolding system or sections of the scaffolding system to be used, has the responsibility for ensuring that the equipment is in good condition.

If the scaffolding system is used successively or at the same time by several contractors, the health and safety coordinator must point out any possible mutual hazards, and all work must be then coordinated.

System-specific

Retract components only when the concrete has sufficiently hardened and the person in charge has given the go-ahead for striking to take place.

Anchoring is to take place only if the anchorage has sufficient concrete strength.

The load-distributing support used, such as planking, must match the respective base. If several layers are required, planks are to be arranged crosswise.

Tighten couplings with screw closures using 50 Nm. This corresponds to a force of 20 kg using a lever arm length of 25 cm.

Secure wedges using a 500 g hammer.

Storage and transportation

Store and transport components ensuring that no unintentional change in their position is possible. Detach lifting accessories and slings from the lowered components only if they are in a stable position and no unintentional change is possible.

Do not drop the components.

Use PERI lifting accessories and slings as well as only those load-bearing points provided on the component.

During the moving procedure

- ensure that components are picked up and set down so that unintentional falling over, falling apart, sliding, falling down or rolling is avoided.
- no persons are allowed to remain under the suspended load.

Always guide pre-assembled scaffolding bays, scaffolding units or scaffolding sections with ropes when moving them by crane.

The access areas on the jobsite must be free of obstacles and tripping hazards as well as being slip-resistant.

For transportation, the surface used must have sufficient load-bearing capacity.

Use original PERI storage and transport systems, e.g. pallet cages, pallets or stacking devices.

Attachment points for PPE



Each specified attachment point is intended for securing one person only!

General information

- The use of personal protective equipment to prevent falling is regulated in the project-related risk assessment that has been prepared by the contractor (user).
- When using personal protective equipment to prevent falling from a height, all valid standards and safety regulations are to be taken into consideration by the scaffolding contractor.
- Each shoring tower is to be secured against tipping by the user.
- The application is valid for the assembly, modification and dismantling of shoring towers.

Requirements

- The shoring underneath the final assembly level is complete.
- This means, all ledgers and diagonal bracing have been installed and the decking is in place as the topmost assembly level.
- The joints of the topmost standards must lie underneath the last assembly level.

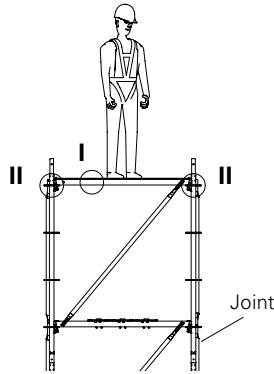

Attachment points

The standard ends in the last assembly level:

- each ledger is in the assembly level (I)
- each rosette in the assembly level (II)

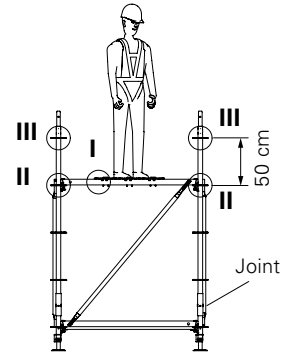

Attachment points

The standard ends 50 cm above the last assembly level:

- each ledger is in the assembly level (I)
- each rosette up to max. 50 cm above the last assembly level (II, III)

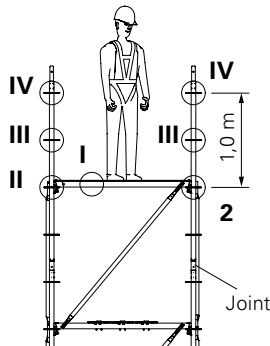

Attachment points

The standard ends 1.0 m above the last assembly level:

- each ledger is in the assembly level (I)
- each rosette up to max. 1.0 m above the last assembly level (II, III, IV)

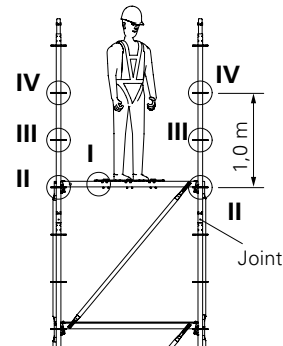

Attachment points

The standard ends 1.5 m above the last assembly level:

- each ledger is in the assembly level (I)
- each rosette up to max. 1.0 m above the last assembly level (II, III, IV)

General

The PERI UP Flex Shoring Tower is shown without additional ledgers. Assemble the shoring tower so that the wider side is lying flat on the ground. The tower is subsequently erected via this side.

Base unit

The base unit is vertically assembled up to a height of 2.0 m. For further assembly, the base unit is positioned on its side and forms the basis for the horizontal assembly.

| Components | Qty |
|--|-----|
| 1 Adjustable Base Plate UJB | 4x |
| 2 Base Standard UVB 24 | 4x |
| 3 Ledger UH 200 Plus* | 2x |
| 3a Ledger UH 150 Plus* | 2x |
| 6 Spindle Locking UJS | 4x |
| 10 H-Brace UBH Flex (as assembly aid) | 1x |

* Length is dependent on the layout of the shoring tower.

Assembly

1. Assemble base frame using the components. (Fig. A1.01)
2. Right-angle adjustment of the frame with H-Brace (10). (Fig. A1.02)
3. Horizontally align frame by adjusting the Adjustable Base Plates (1).
4. Securely fix all wedges to the ledgers using a 500 g hammer (hammer in tightly).
5. Secure Adjustable Base Plates by means of Spindle Locking devices. (Fig. A1.01a)



The H-Braces also ensure the squareness during crane transport.

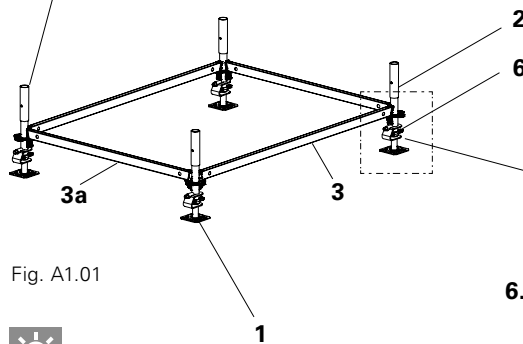
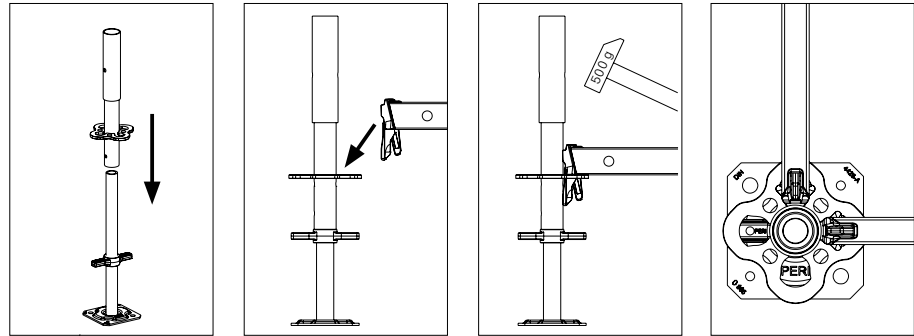

Fig. A1.01



– Align all the pegging holes in the Base Standard in one direction.

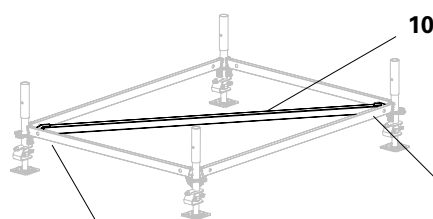

Fig. A1.02

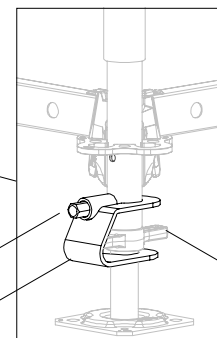
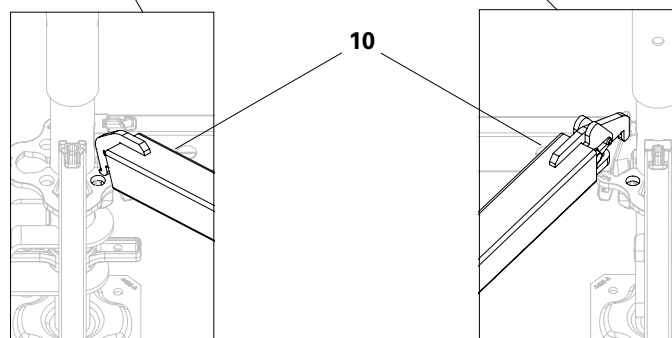

Fig. A1.01a

Fix the Spindle Locking UJS (6) to the bottom hole of the Base Standard by screwing in the bolt (6.1). The Quick Jack Nut (1.1) must be positioned within the Spindle Locking UJS.

Standards and ledgers

| Components | Qty |
|-------------------------------------|-----|
| 4 Standard UVR 200 | 4x |
| 3 Ledger UH 200 Plus* | 2x |
| 3a Ledger UH 150 Plus* | 2x |
| 5 Ledger Brace UBL 200/150* | 2x |
| 5a Ledger Brace UBL 150/150* | 2x |
| 7 Locking Pin Ø 48/57 | 4x |

* Length is dependent on the layout of the shoring tower.

Ledger spacing

- Example: ledger spacing according to the type test 1.50 m.
- Other ledger spacings are possible but these required separate static proof. They do not form part of the type test.

Assembly

1. Insert Standards (4) and tightly connect using Locking Pins (7). (Fig. A1.03c)
2. Install Ledgers (3).
3. Insert Ledger Braces (5) with the finger (5.1) in the bottom Ledgers (3). (Fig. A1.03b)
4. Insert the gravity pin (5.2) into the holes of the top ledger, turn pin to secure. (Fig. A1.03a)
5. Secure Ledgers with a hammer.
6. Position Base Unit on support timbers (min. 6 cm high) for further assembly.
7. If necessary, the H-Brace (10) can be removed.

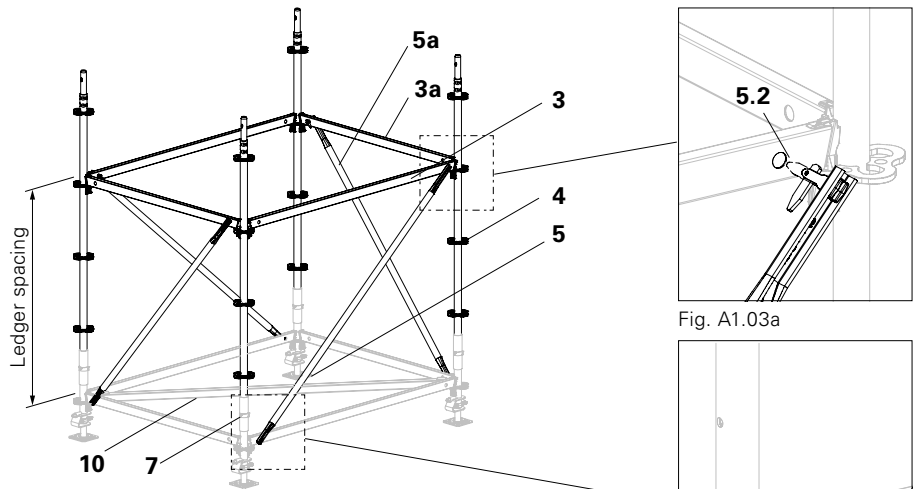

Fig. A1.03



- Ledgers are secured with hammer blows only after ledger braces have been installed.
- As an alternative to Locking Pin Ø 48/57, Bolt M10x70, 8.8 with Nut M10 (4x) can always be used.

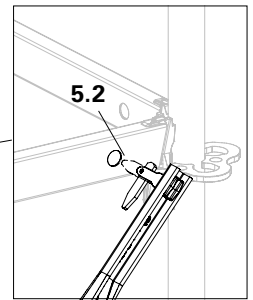

Fig. A1.03a

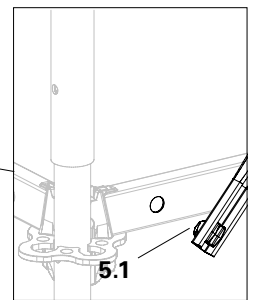

Fig. A1.03b

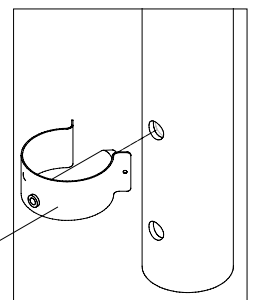

Fig. A1.03c

Height units

Standards

| Components | Qty |
|-----------------------|-----|
| 4 Standard UVR 200 | 4x |
| 7 Locking Pin Ø 48/57 | 4x |

Assembly

Insert Standards (4) and tightly connect using Locking Pins (7).
(Fig. A1.04)

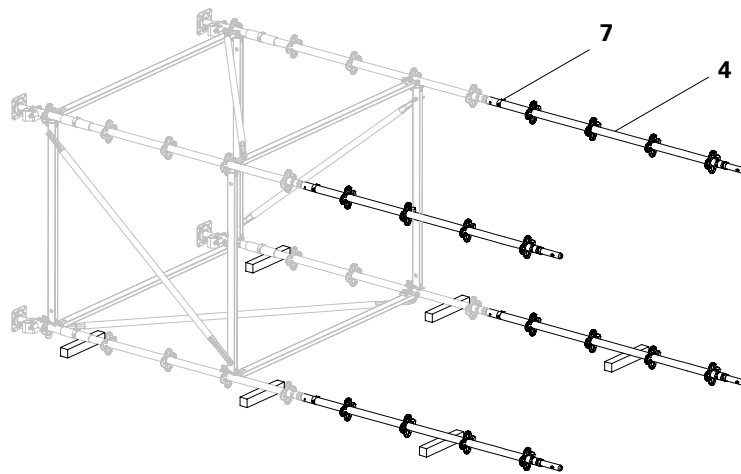

Fig. A1.04

Ledgers and diagonals

| Components | Qty |
|------------------------------|-----|
| 3 Ledger UH 200 Plus* | 2x |
| 3a Ledger UH 150 Plus* | 2x |
| 5 Ledger Brace UBL 200/150* | 2x |
| 5a Ledger Brace UBL 150/150* | 2x |

* Dependent on the layout of the shoring tower.

Assembly

1. Install Ledgers (3, 3a) using 1.50 m spacings. (Every third rosette)
2. Mount Ledger Braces (5, 5a):
 - Mount the bottom-positioned Ledger Brace (5) from the inside.
 - Mount the remaining Ledger Braces from the outside. (Fig. A1.05)
3. Repeat steps 1 and 2 until the required end height has been reached. Last Standard = Top Standard UVH, see Top Tower Unit.

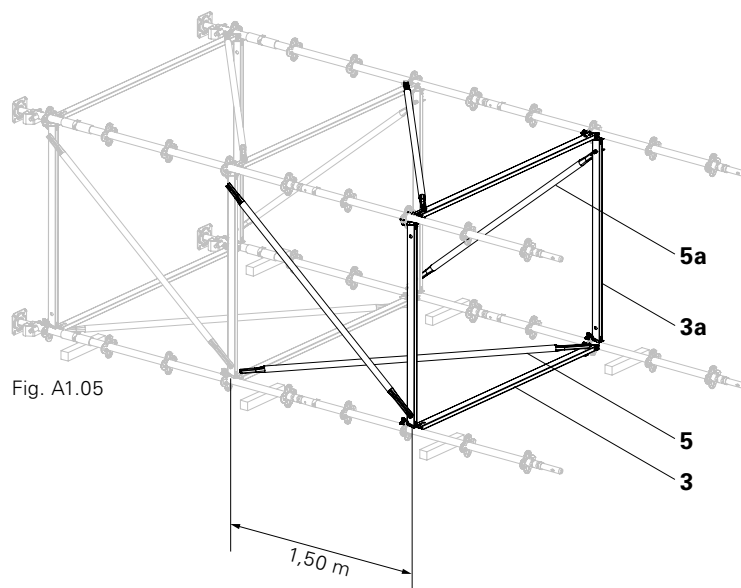

Fig. A1.05

Top tower unit



Shown here in a vertical position due to didactical reasons!

The assembly example shows a height adjustment of 1.50 m. (Fig. A1.07c)

| Components | Qty |
|--------------------------------------|-----|
| 4a Top Standard UVH 150* | 4x |
| 3 Ledger UH 200 Plus* | 4x |
| 3a Ledger UH 150 Plus* | 4x |
| 5 Ledger Brace UBL 200/150* | 2x |
| 5a Ledger Brace UBL 150/150* | 2x |
| 5b Ledger Brace UBL 200/100* | 2x |
| 5c Ledger Brace UBL 150/100* | 2x |
| 7 Locking Pin Ø 48/57 | 4x |
| 11 Cross Forkhead TR 38-70/50 | 4x |
| 12 Head Spindle Locking UJH | 4x |

* Dependent on the shoring tower layout and height.

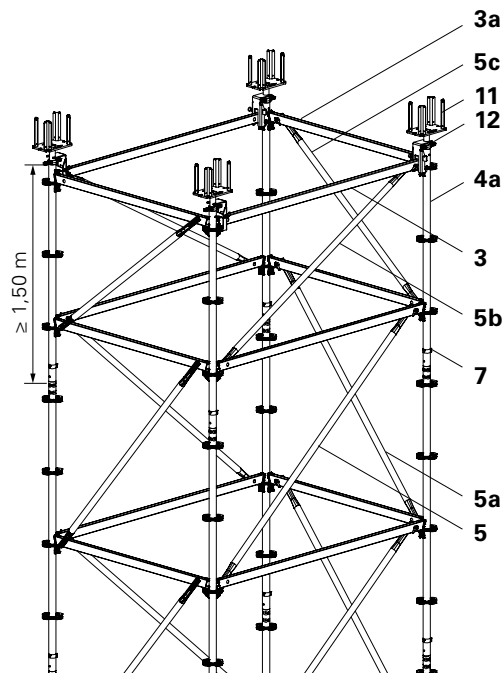

Fig. A1.06

Assembly

1. Insert Top Standards (4a) to adjust the height (UVH 100, 150, 200, 250).
 2. Tightly connect Top Standards using Locking Pins (7).
 3. Install Ledgers (3, 3a).
 4. Mount Ledger Braces (5 – 5c) and secure Ledgers.
 5. Insert Cross Forkhead (11).
 6. Place the Head Spindle Locking (12) at an angle on the Ledger and first insert the hooks (12.1) into the rosette holes (4.1) from below.
 7. Swivel the Head Spindle Locking upwards over the Quick Jack Nut (11.1), hammer in wedge (12.2) and secure with cotter pin (12.3).
- (Fig. A1.06 – A1.06b)

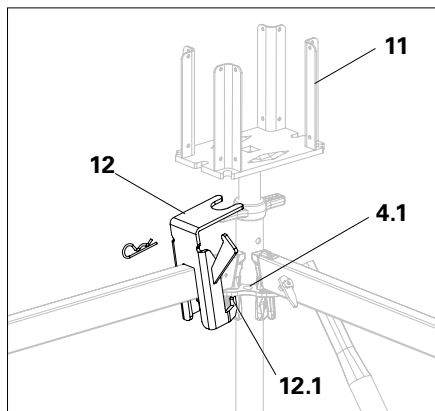

Fig. A1.06a

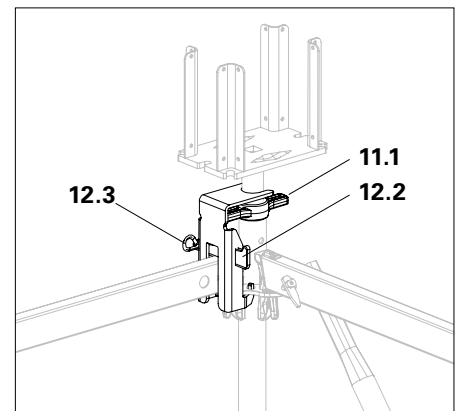
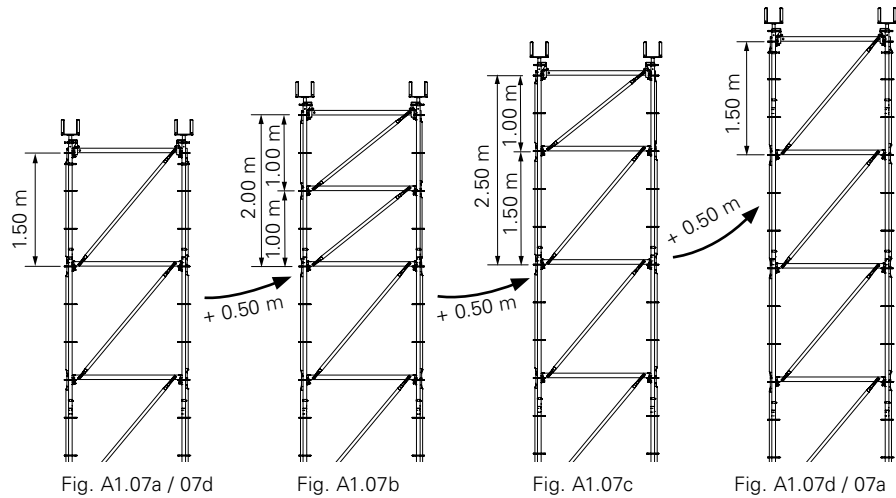

Fig. A1.06b

Height adjustment

Height adjustment takes place through the use of corresponding Top Standards (heights of 100/150/200/25 cm) and adjusting the spacing of the Ledgers. (Fig. A1.07a – A1.07d)



Erection with the crane



- **Risk of injury from falling components!**
Ensure that all Standards are tightly connected!
- **Risk of falling!**
Ensure that removal of the lifting gear is carried out from a safe working position!
- **Only attach to those rosette nodes which are directly connected to the Ledgers.**

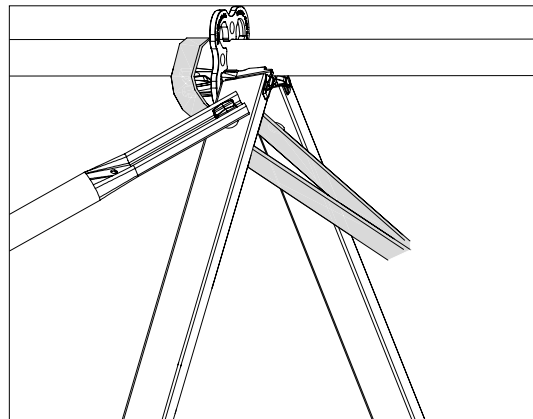

Fig. A1.08a

Erection

1. Completely spindle in the bottom Adjustable Base Plates in order to prevent overloading the components during erection.
2. Place four chains or textile lifting slings, e.g. round slings, underneath those rosette nodes complete with Ledgers.
3. Erect shoring tower.
4. Whilst suspended on the crane lifting gear, adjust the Adj. base plates to the required height.

(Fig. A1.08 + A1.08a)

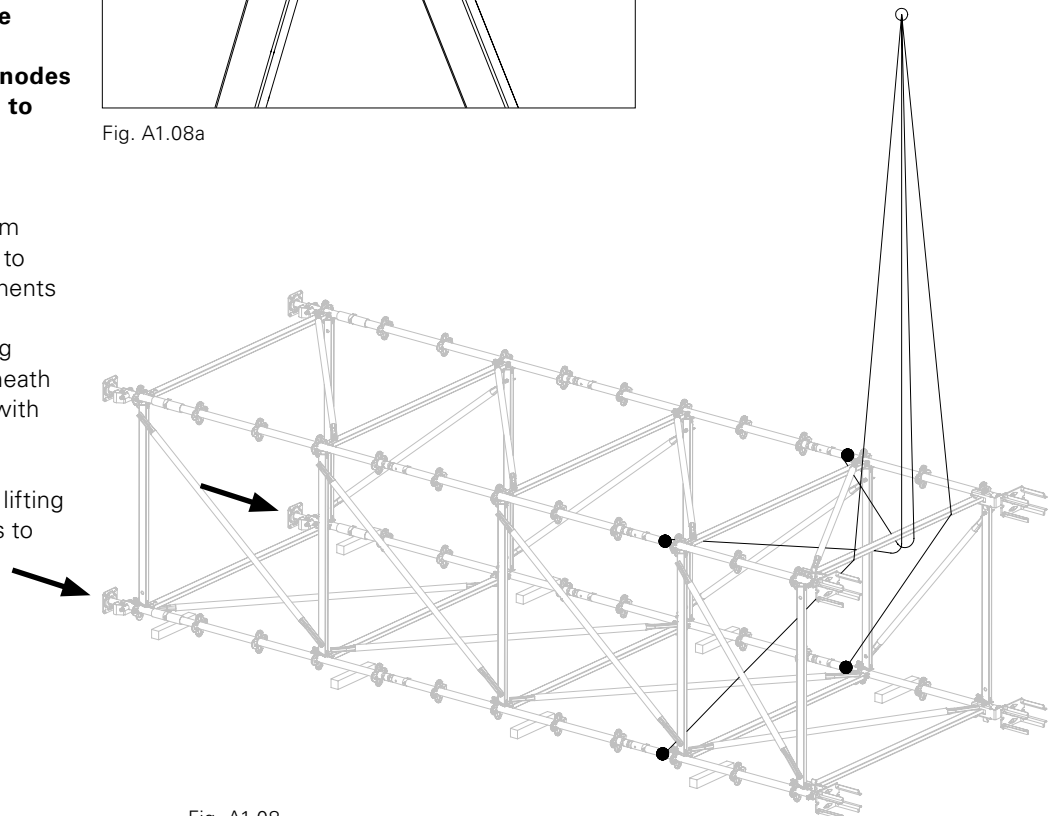

Fig. A1.08

Dismantling



- **Risk of injury from falling components!**
Ensure that all Standards are tightly connected!
- **Risk of falling!**
Attach the lifting gear from a safe working position!
- **Only attach to rosette nodes which are directly connected to the Ledgers.**

1. Place four chains or textile lifting slings, e.g. round slings, underneath those rosette nodes complete with Ledgers, and attach to the crane lifting gear. (Fig. A1.09)
2. Completely spindle in the subsequent bottom Adjustable Base Plates in order to prevent overloading the components during setting down.
3. Using the wider side, position tower on support timbers with the crane.
4. Dismantle the tower beginning with the head side:
 - Remove Head Spindles.
 - Remove each height unit one after the other. First dismantle the Ledger Braces and Ledgers, and then the Standards.
 - Dismantle the base unit.
5. Store individual components accordingly, e.g. in pallets.

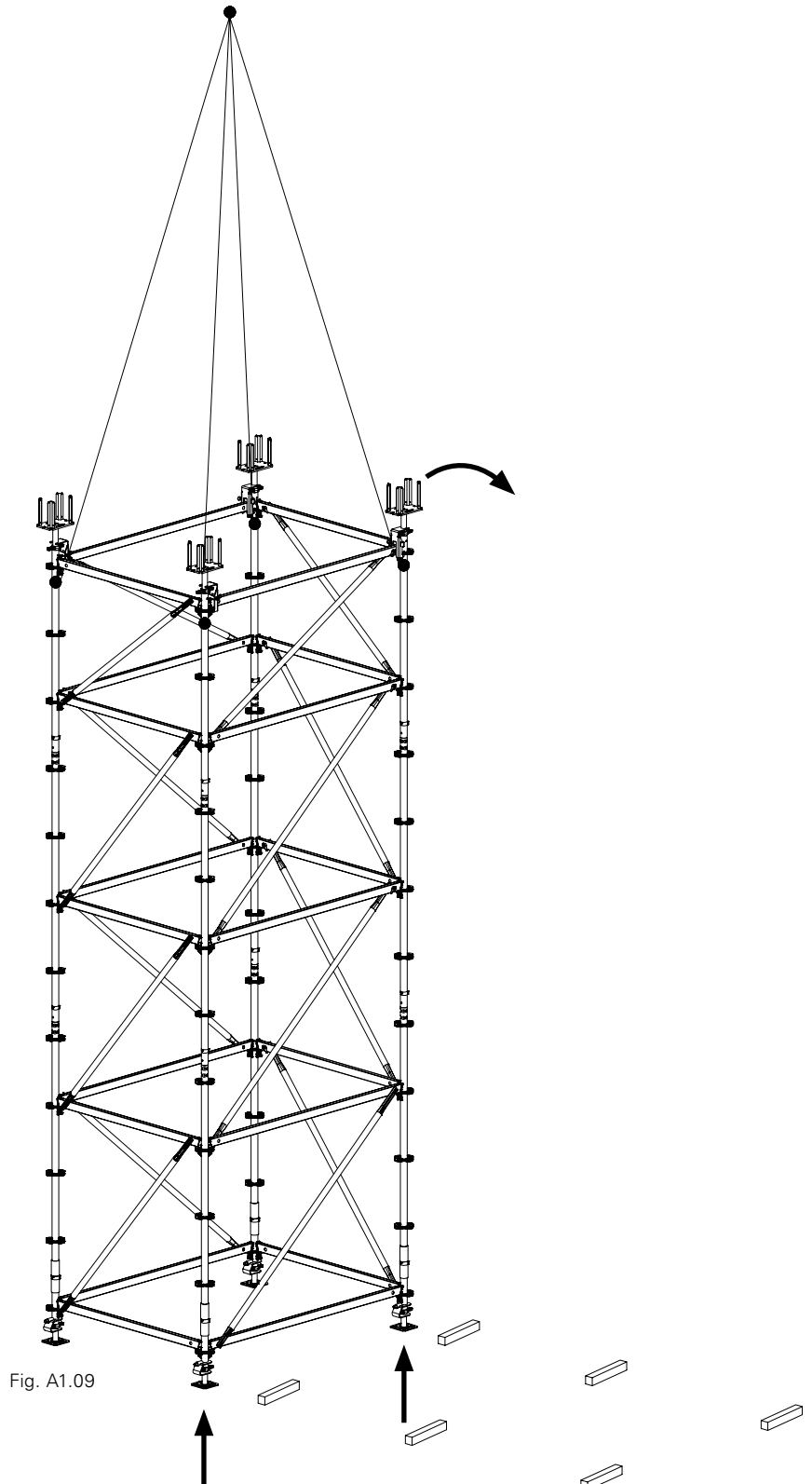

Fig. A1.09

Ground plans

For transferring concentrated loads while simultaneously saving on materials, up to 2 Additional Frames (VSS) can be connected on an individual tower. The spacing of the frames to one another is freely selectable according to the requirements. (Fig. A2.01)

A maximum of 2x VSS can be connected one behind the other. Extensions over the corners are not permitted.

The assembly example shown is carried out on a 2.00 x 1.50 m shoring tower with 2x VSS, each 1.00 m.

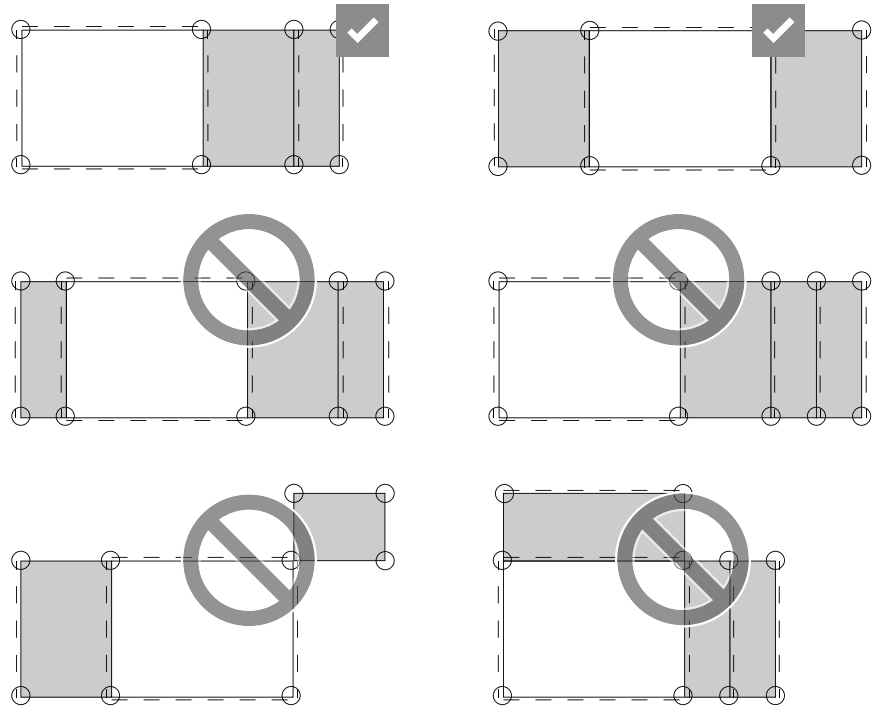

Fig. A2.01

Dimensions

Minimum size of an individual tower: 1.50 x 1.50 m.

Grid dimensions for VSS: 0.25 / 0.50 / 0.75 / 1.00 / 1.50 / 2.00 / 2.50 / 3.00 m.

Second dimension as for the respective base tower side. (Fig. A2.01a)

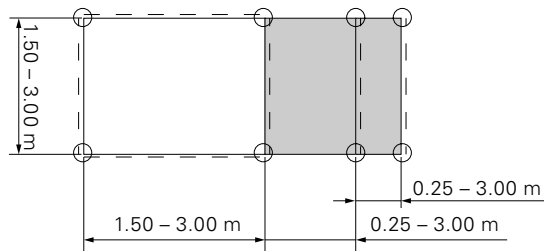

Fig. A2.01a

Arrangement of the diagonals

In the direction of the Additional Frames, only additional diagonals are required in the main tower. Transverse to the direction of the Additional Frames, brace all frame columns of the main tower and the Additional Frames with diagonals. (Fig. A2.01b)

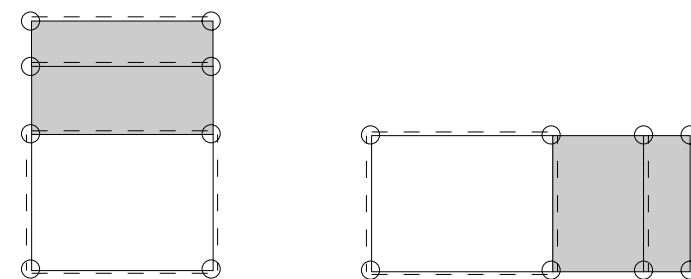

Fig. A2.01b

Key:
 - - - - - Diagonal bracing

General

Assembly correspondingly takes place as described in section A1, PERI UP Flex Shoring Tower.

Assemble the shoring tower so that the wider side (with Additional Frames) is lying flat on the ground. The tower is subsequently erected via this side.

Base Frame VSS

| Components | Qty |
|------------------------------------|-----|
| 1 Adjustable Base Plate UJB | 4x |
| 2 Base Standard UVB 24 | 4x |
| 3 Ledger UH 150 Plus | 2x |
| 3a Ledger UH 100 Plus | 4x |
| 6 Spindle Locking UJS | 4x |

(Fig. A2.02)

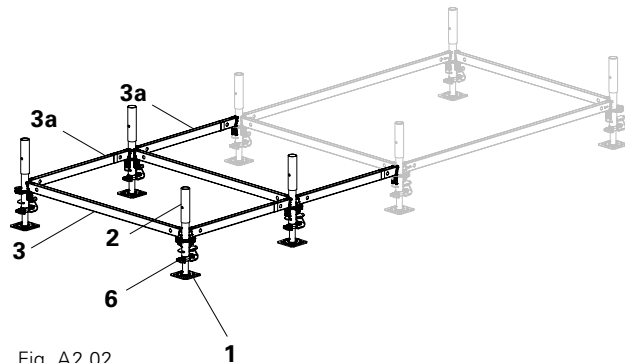

Fig. A2.02

Standards and Ledgers VSS

| Components | Qty |
|------------------------------------|-----|
| 4 Standard UVR 200 | 4x |
| 3 Ledger UH 150 Plus | 2x |
| 3a Ledger UH 100 Plus | 4x |
| 5a Ledger Brace UBL 150/150 | 2x |
| 7 Locking Pin Ø 48/57 | 4x |

(Fig. A2.03)

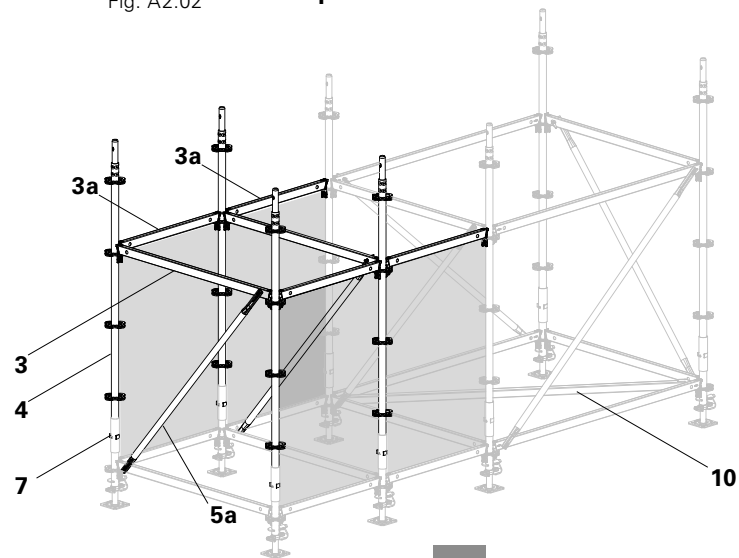

Fig. A2.03



No additional diagonals are required in the marked fields!



- Ledgers are secured with hammer blows only after Ledger Braces have been installed.
- As an alternative to the Locking Pin Ø 48/57, Bolt M10x70, 8.8 with Nut M10 (4x) can always be used.

Height Units VSS

Standards

| Components | Qty |
|------------------------------|-----|
| 4 Standard UVR 200 | 4x |
| 7 Locking Pin Ø 48/57 | 4x |

(Fig. A2.04)

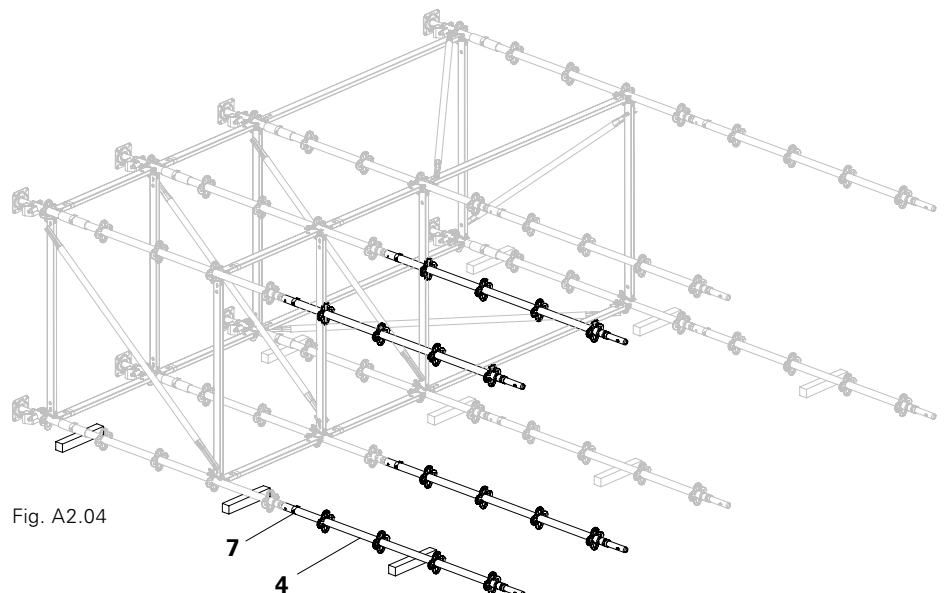

Fig. A2.04

Ledgers and Diagonals VSS

| Components | Qty |
|------------------------------------|-----|
| 3 Ledger UH 150 | 2x |
| 3b Ledger UH 100 | 4x |
| 5a Ledger Brace UBL 150/150 | 2x |

(Fig. A2.05)

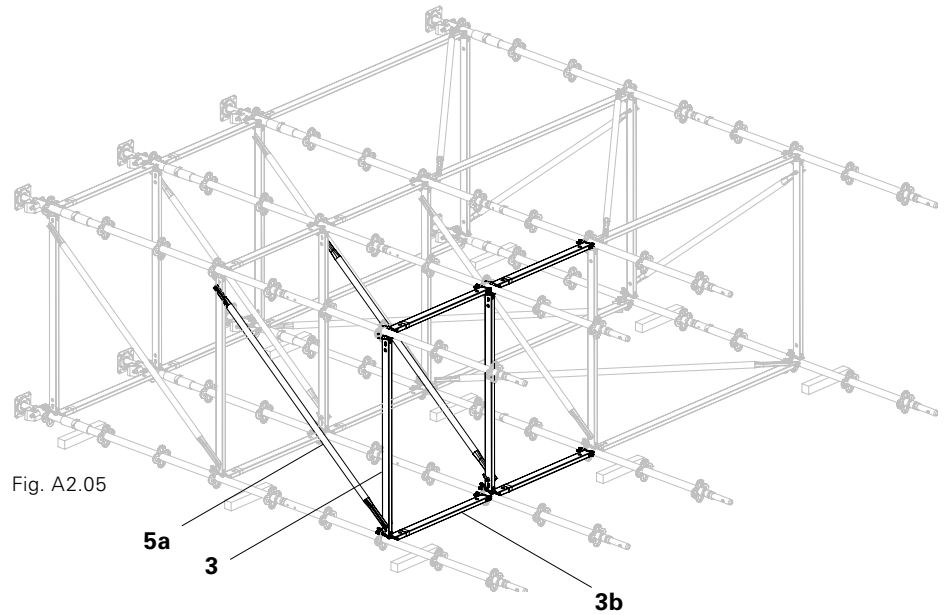

Fig. A2.05

Head Element with Height Adjustment VSS



Shown here in a vertical position due to didactical reasons!

The assembly example shows a height adjustment of 2.50 m. (Fig. A2.06)

| Components | Qty |
|--------------------------------------|-----|
| 4a Top Standard UVH 250* | 4x |
| 3a Ledger UH 150 Plus* | 4x |
| 3b Ledger UH 100 Plus* | 8x |
| 5a Ledger Brace UBL 150/150* | 2x |
| 5c Ledger Brace UBL 150/100* | 2x |
| 7 Locking Pin Ø 48/57 | 4x |
| 11 Cross Forkhead TR 38-70/50 | 4x |
| 12 Head Spindle Locking UJH | 4x |

* Dependent on the layout of the shoring tower and height.

Height adjustment takes place through the use of corresponding Top Standards (100/150/200/25 cm heights) and adjusting the spacing of the Ledgers. see Section A1 PERI UP Flex Shoring Tower, Height Adjustment.

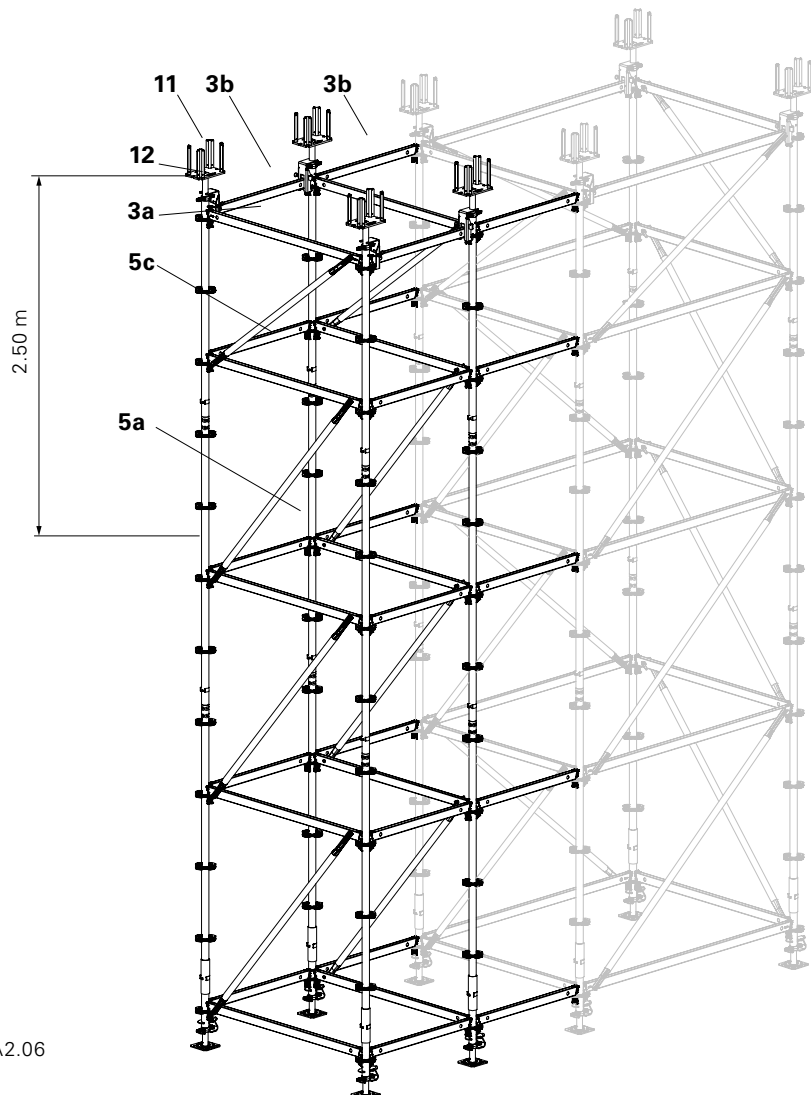

Fig. A2.06

Erection with the crane



- Risk of injury from falling components!
Ensure that all Standards are tightly connected!
- Risk of falling!
Ensure that removal of the lifting gear is carried out from a safe working position!
- Only attach to those rosette nodes which are directly connected to the Ledgers.

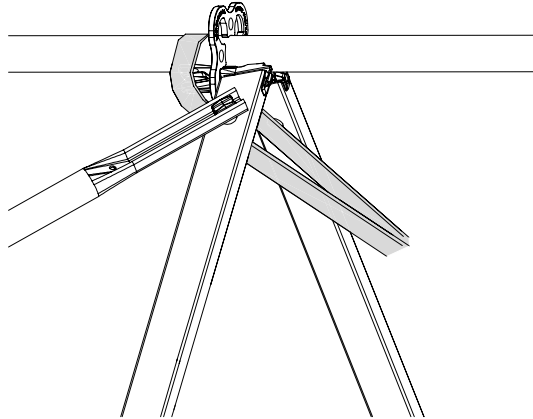

Fig. A2.08a

Erection

1. Completely spindle in the bottom Adjustable Base Plates in order to prevent overloading the components during erection.
2. Place four chains or textile lifting slings, e.g. round slings, underneath those rosette nodes complete with Ledgers.
3. Erect shoring tower.
4. Whilst suspended on the crane lifting gear, adjust the Adj. Base Plates to the required height.
(Fig. A2.08 + A2.08a)

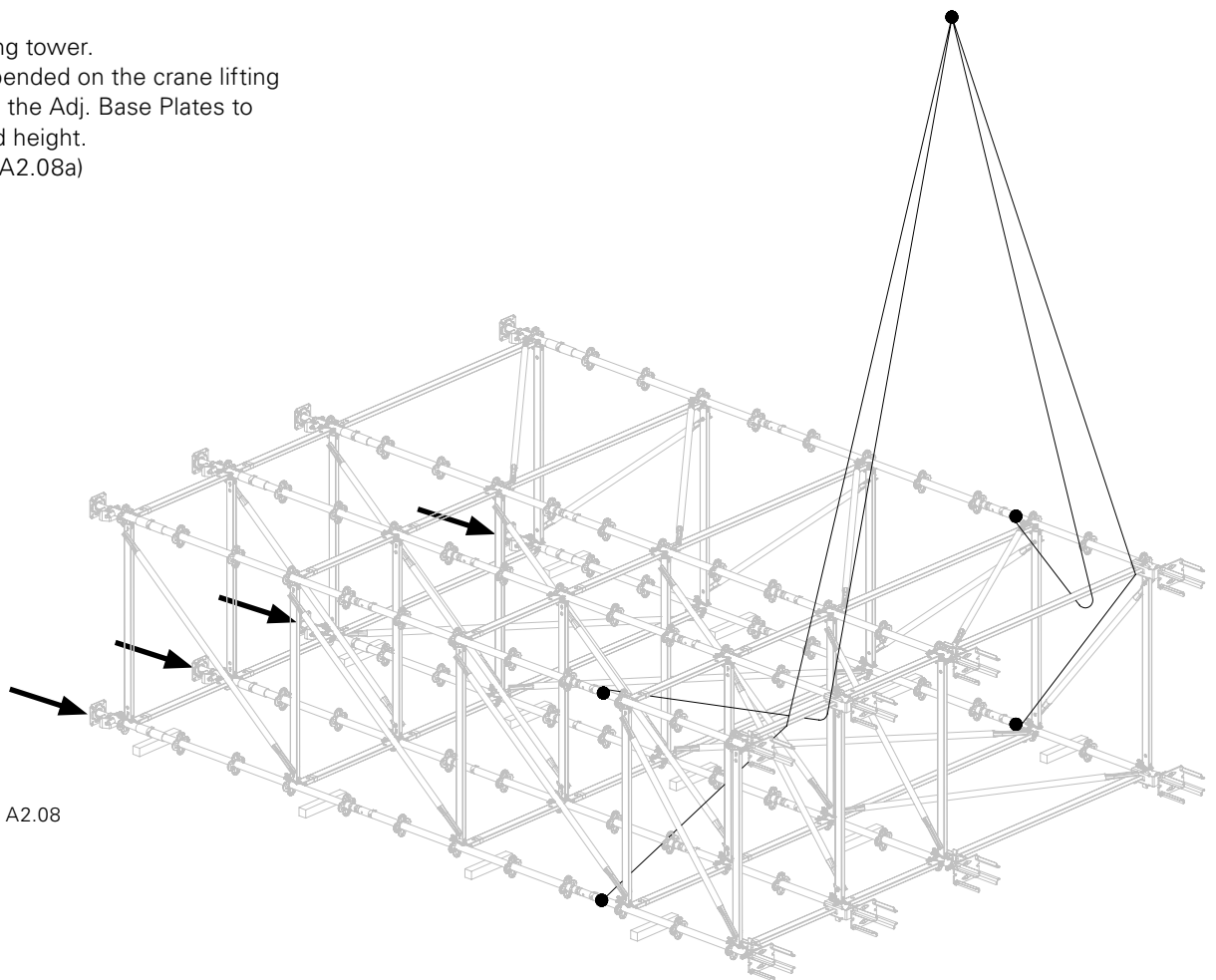

Fig. A2.08

Dismantling



- **Risk of injury from falling components!**
Ensure that all Standards are tightly connected!
- **Risk of falling!**
Attach the lifting gear from a safe working position!
- **Only attach to those rosette nodes which are directly connected to the Ledgers.**

1. Place four chains or textile lifting slings, e.g. round slings, underneath those rosette nodes complete with Ledgers, and attach to the crane lifting gear.
 2. Completely spindle in the subsequent bottom Adjustable Base Plates in order to prevent overloading the components during setting down.
 3. Using the wider side, position tower on support timbers with the crane.
 4. Dismantle the tower beginning with the head side:
 - Remove Head Spindles.
 - Remove each Height Unit one after the other. First dismantle the Ledger Braces and Ledgers, and then the Standards.
 - Dismantle the base unit.
 5. Store individual components accordingly, e.g. in pallets.
- (Fig. A2.09)

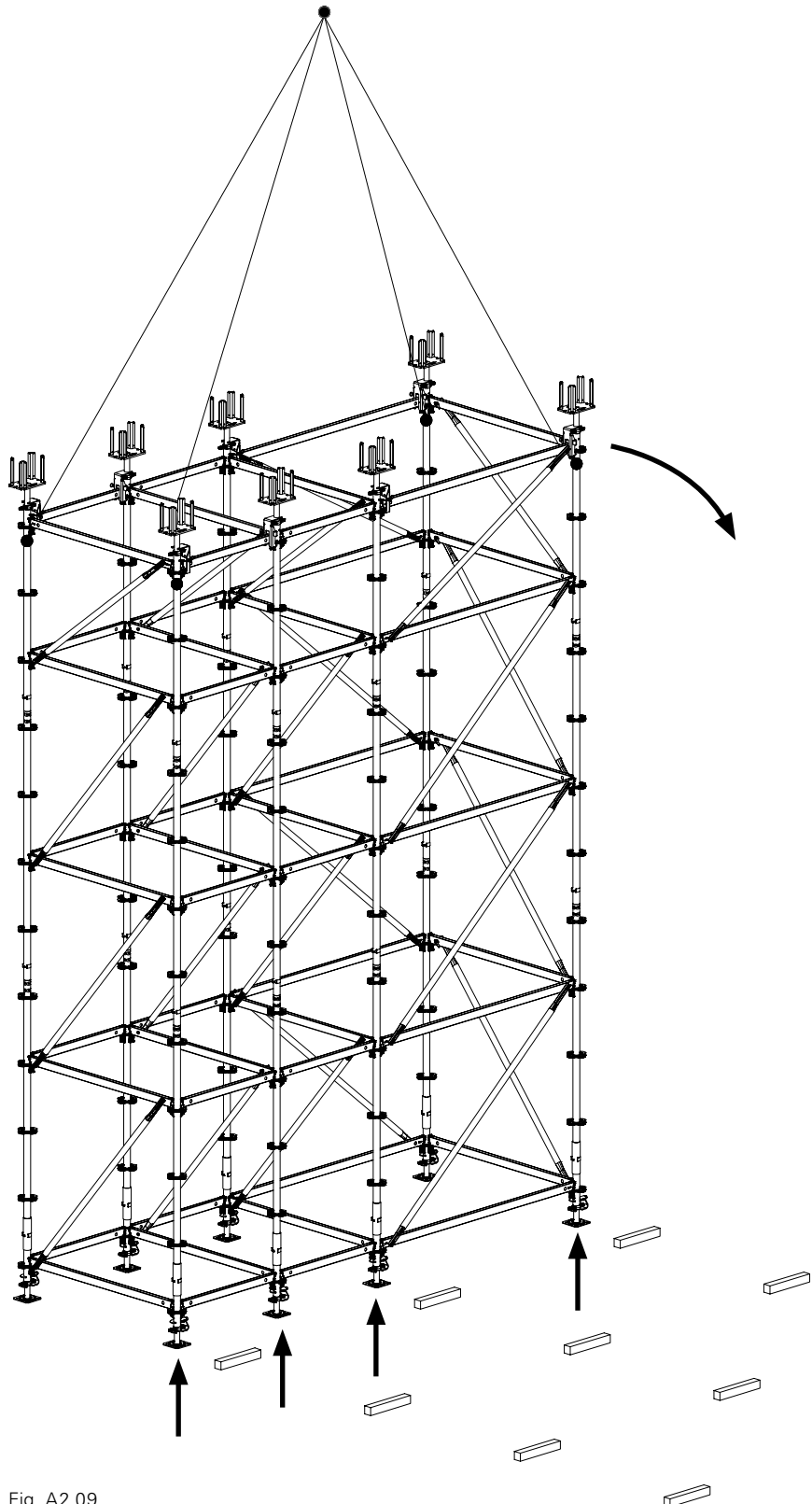

Fig. A2.09

General

PERI UP Flex Shoring Tower Plus facilitates an increase in the load-bearing capacity of the standards or significantly larger spindle extensions which are required when moving slab tables under beams.

Preparation

Preparation of the Head Spindles

4 Head Spindles are required.
Number of pieces per spindle.

| Components | Qty |
|--|-----|
| 26 Head Plate for Spindle Tube TR 48 | 1x |
| 21 Spindle Tube TR 48 | 1x |
| 22 Bolt Ø 16 x 65/86 | 1x |
| 23 Cotter Pin 4/1 | 1x |
| 24 Quick Jack Nut TR 48-2 | 1x |

Preparation of the Adjustable Base Plates

4 Adjustable Base Plates are required.
Number of pieces per spindle.

| Components | Qty |
|--|-----|
| 20 Base Plate for Spindle Tube TR 48 | 1x |
| 21 Spindle Tube TR 48 | 1x |
| 22 Bolt Ø 16 x 65/86 | 1x |
| 23 Cotter Pin 4/1 | 1x |
| 24 Quick Jack Nut TR 48-2 | 1x |

Assembly

1. Screw Quick Jack Nut (24) on the Spindle Tube (21) – using only a few turns.
2. Position the Head Plate (26) with the top side facing downwards.
3. Place the Spindle Tube on the Head Plate and connect using Bolts (22).
4. Secure Bolts with Cotter Pins (23).
→ Head Spindles have now been prepared. (Fig. A3.01)

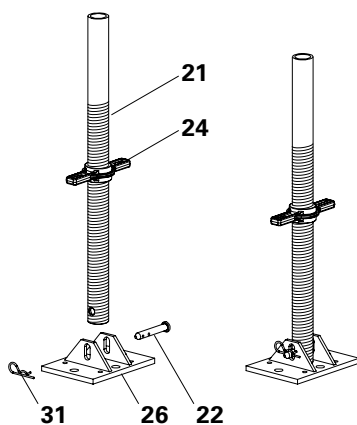

Fig. A3.01

Assembly

1. Screw Quick Jack Nut (24) on the Spindle Tube (21) – using only a few turns.
2. Position Base Plate.
3. Insert Spindle Tube on Base Plate (20).
4. Connect Base Plate and Spindle Tube using Bolts (22).
5. Secure Bolts by means of Cotter Pins (23).
→ Adjustable Base Plates have now been prepared. (Fig. A3.02)

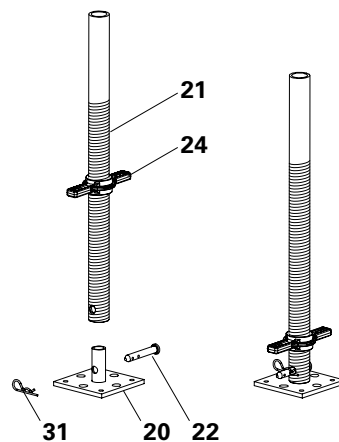

Fig. A3.02

Preparation of the Head Elements

2 Head Elements are required.

Number of pieces per Head Element.

The Head Element forms the wider side of the shoring tower.

| Components | Qty |
|-------------------------------------|-----|
| Prepared Head Spindles | 2x |
| 3 Ledger UH Plus* | 1x |
| 27 Spindle Locking UJS Plus | 2x |
| 28 Top Standard UVH 165 Plus | 2x |
| 32 Shoring Brace UBS* | 2x |

* Length is dependent on the layout of the shoring tower.

Assembly

- Place the Top Standards (28) with smaller diameters on timbers and attach Ledgers (3). Securely fix the wedges. (Fig. A3.03)
- Install Shoring Braces (32) crosswise.
 - Insert the Base Connection (32.1) into the round rosette hole at a 45° angle and swivel the Shoring Brace inwards in the ledger level. (Fig. A3.04 + A3.04a)
 - Pull out the spring bolt (32.3) on the head piece, and push the head piece (32.2) laterally onto the rosette until the bolt is positioned in the round rosette hole. (Fig. A3.04 + A3.04b)
 - Release the spring bolt and allow it to engage in the rosette hole. (Fig. A3.04)
 - Turn the Head Element and mount the Shoring Brace on the other side in the same way. (Fig. A3.05)

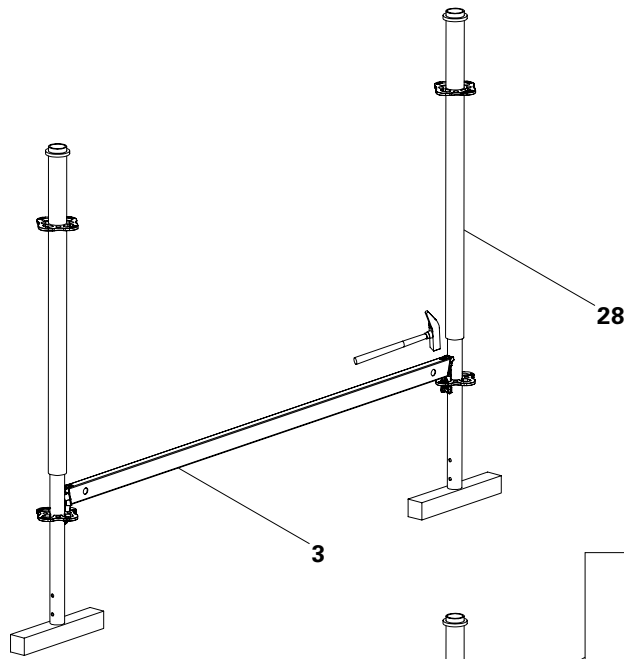

Fig. A3.03

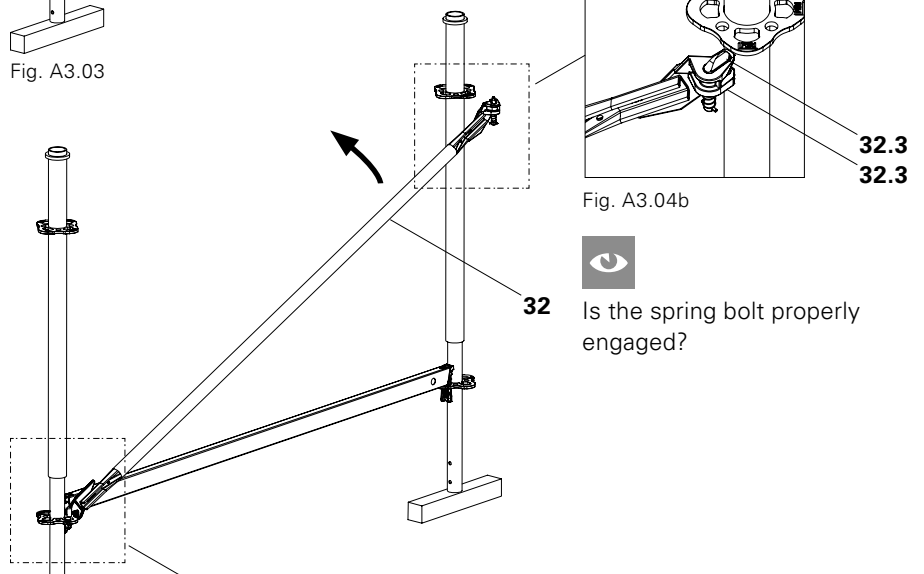

Fig. A3.04b



Is the spring bolt properly engaged?

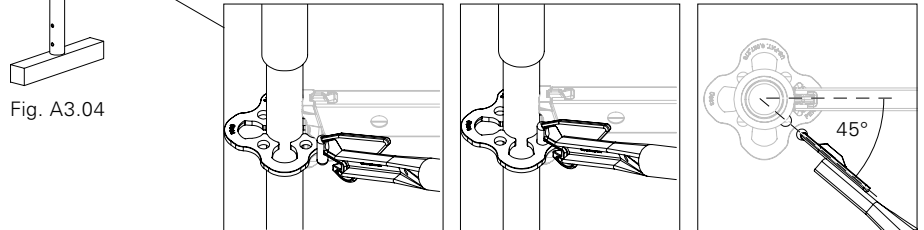

Fig. A3.04a



Direction of the Shoring Braces "from bottom left to top right" each time.

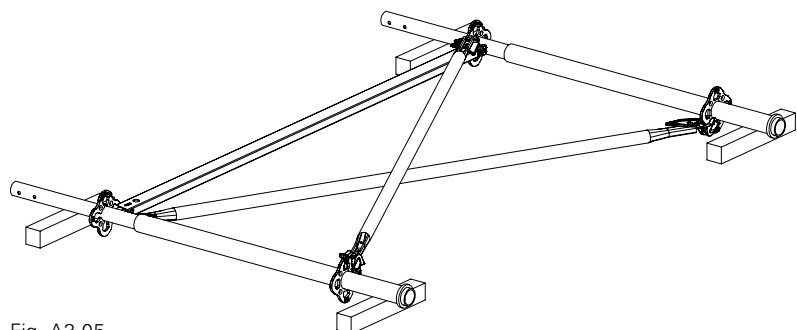

Fig. A3.05

3. Insert the prepared Head Spindles into the Top Standards and adjust to the required height.
 4. Secure Head Spindles with the Spindle Locking.
 - For this purpose, pull out Cotter Pins (27.2).
 - Laterally turn the positioning pins (27.1) and pull out as far as the round hole.
 - Position the collar (27.3) of the Spindle Locking behind the ring (28.1) of the Top Standard.
 - Quick Jack Nut (24) must engage in the recess (27.4) of the Spindle Locking.
 - Insert positioning pin (27.1) through the hole (27.5) and secure by means of a Cotter Pin (27.2).
- Head Element has now been prepared. (Fig. A3.06 – A3.06b)

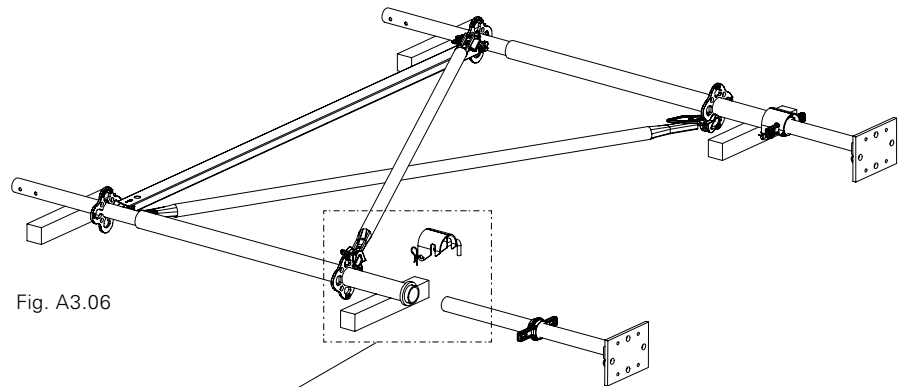

Fig. A3.06

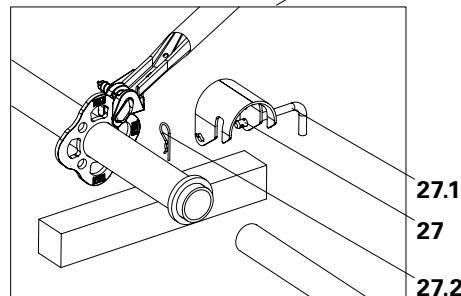

Fig. A3.06a

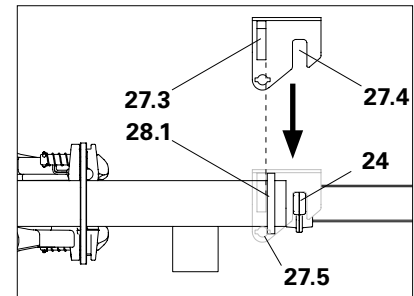

Fig. A3.06b



Alternatively: use the Cross Forkhead TR 48.

Preparation of the Base Element

2 Base Elements are required.
 Number of pieces per Base Element.
 The Base Element forms the wider side of the shoring tower.

| Components | Qty |
|--------------------------------------|-----|
| Prepared Adjustable Base Plate | 2x |
| 25 Base Standard UVB 135 Plus | 2x |
| 3 Ledger UH 200 Plus* | 1x |
| 27 Spindle Locking UJS Plus | 2x |
| 32 Shoring Brace UBS | 2x |

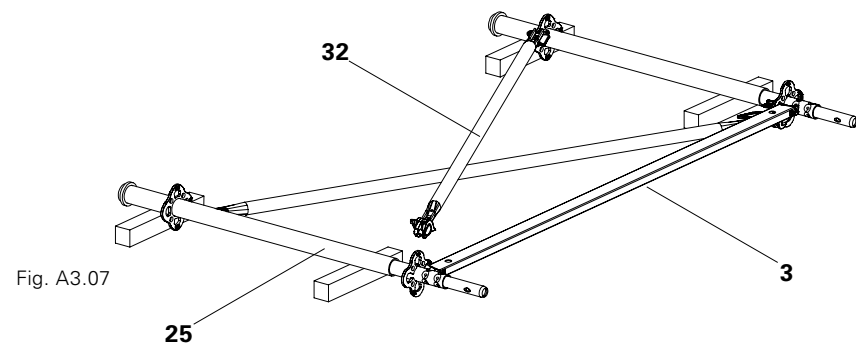

Fig. A3.07

Assembly

1. Connect Base Standards (25) to the Ledger (3).
 2. Install Shoring Braces (32) crosswise. (Fig. A3.07)
 3. Insert the prepared Adjustable Base Plates in the Base Standards (25) and secure with Spindle Locking (27). (Fig. A3.07a)
- Base Element has now been prepared.

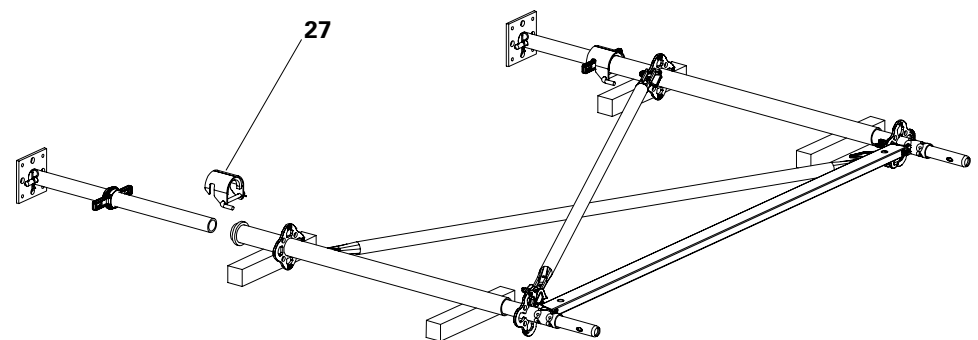

Fig. A3.07a

Assembly

Assembly of the PERI UP Flex Shoring Tower Plus takes place horizontally, beginning with the Head Element. Assemble the shoring tower so that the wider side (with Additional Frames) is lying flat on the ground. The tower is subsequently erected via this side.

Assembly

Position timbers minimum 6 cm thick as support on a flat working surface.

1. Insert Standards (4) into the prepared head section (34) and secure with Locking Pins (7).
2. Connect Standards with Ledgers (3) and Ledger Braces (5) to form a wider shear frame arrangement.
3. Assemble additional Standards, Ledgers and Ledger Braces until the required length has been realized. Secure all Standards with Locking Pins and securely fix all wedges.
4. Position the prepared base section (33) and secure with Locking Pins (7). (Fig. A3.08)

| Components | Qty |
|-------------------------------------|-----|
| 34 Prepared Head Element | 2x |
| 33 Prepared Base Element | 2x |
| 3 Ledger UH 200 Plus* | x |
| 3a Ledger UH 150 Plus* | x |
| 4 Standard UVR 200 | * |
| 5 Ledger Brace UBL 200/150* | x |
| 5a Ledger Brace UBL 150/150* | x |
| 7 Locking Pin Ø 48/57 | *x |

* Dependent on the layout of the shoring tower and height.

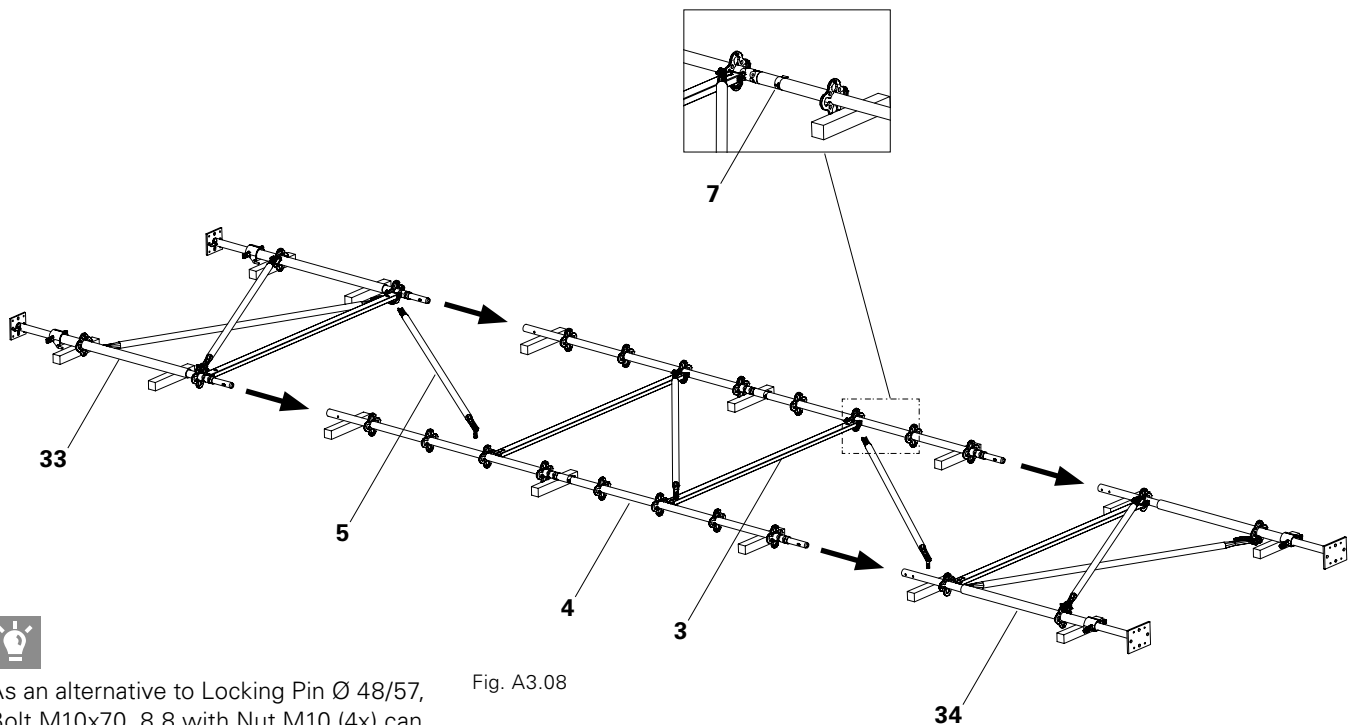

Fig. A3.08



As an alternative to Locking Pin Ø 48/57, Bolt M10x70, 8.8 with Nut M10 (4x) can always be used.

5. Mount Ledgers (3a) for the narrow side of the shoring tower on both shoring tower standards. Do not secure the wedges yet.
6. Place the prepared Head Element (34) of the second shear frame arrangement on the UH Ledgers and support temporarily.
7. Brace the Head Element by means of Shoring Braces (32). Remove support. (Fig. A3.09)

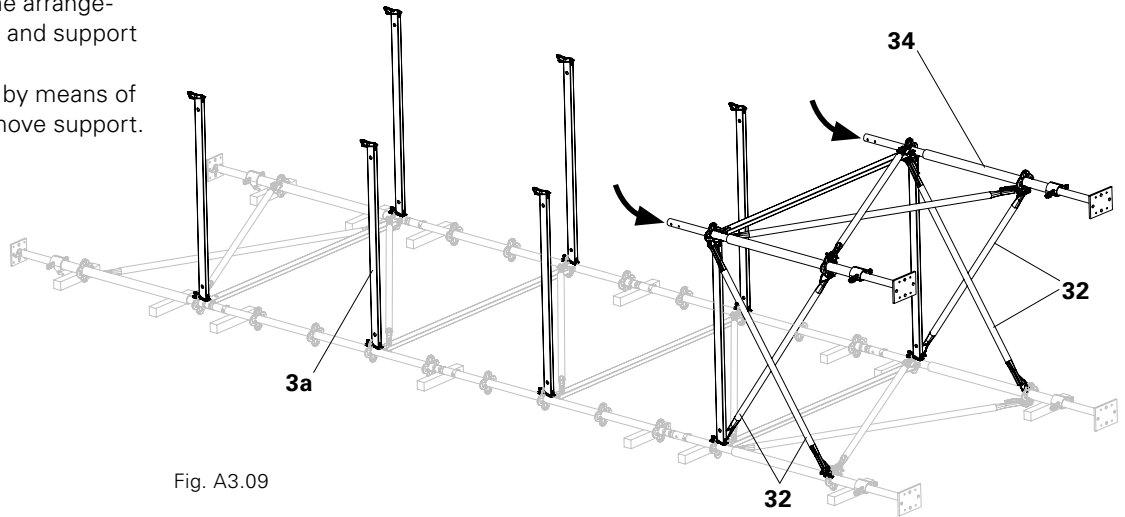

Fig. A3.09

8. Beginning on the head side, attach the Standards (4) for the second shear frame arrangement to the Ledgers and secure with Cotter Pins (7). (Fig. A3.10)

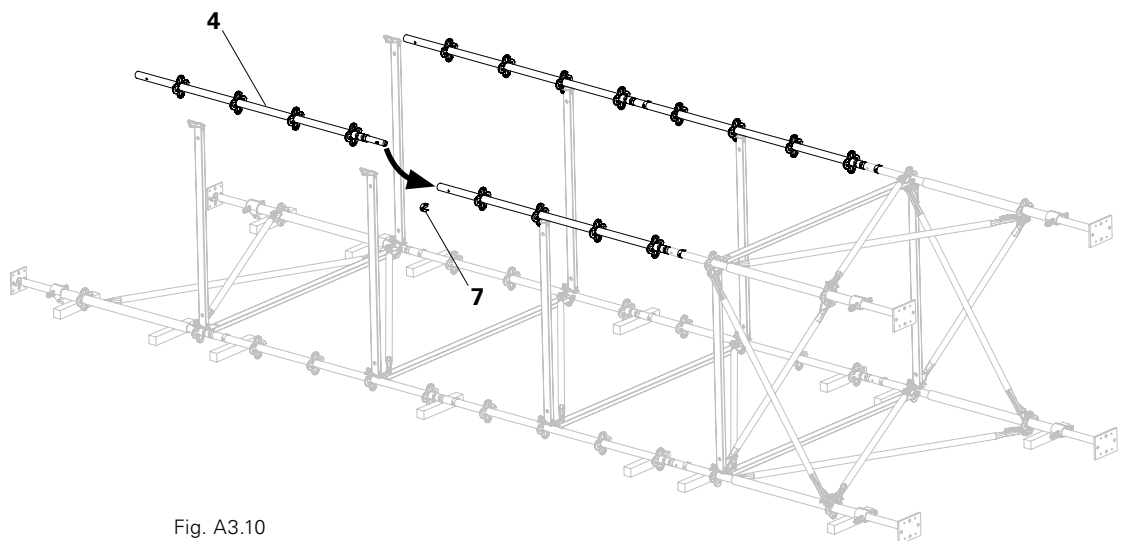

Fig. A3.10

9. Attach prepared Base Element (33) for the second shear frame arrangement and secure with Locking Pins (7). Provide the Base Element with temporary support.
 10. Brace the Base Element using Shoring Braces (32). Remove support.
- (Fig. A3.11)

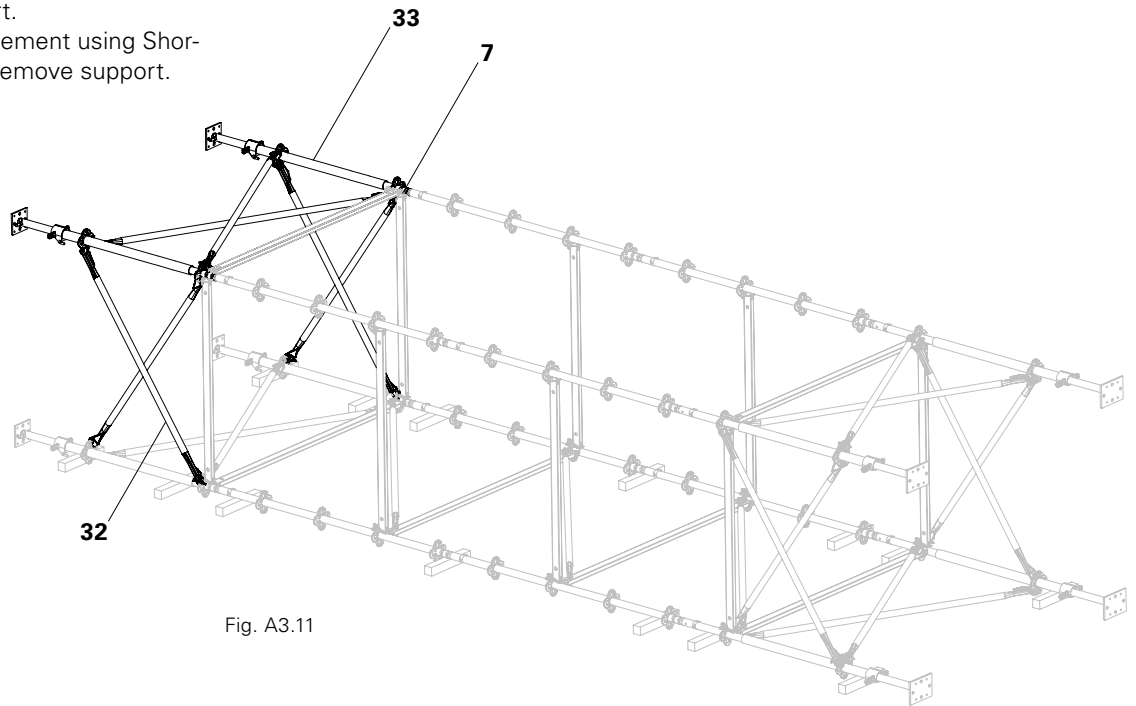

Fig. A3.11

11. Brace Standards by means of Ledgers (3) and Ledger Braces (5, 5a).
 12. Securely fix the wedges of all Ledgers.
- (Fig. A3.12)

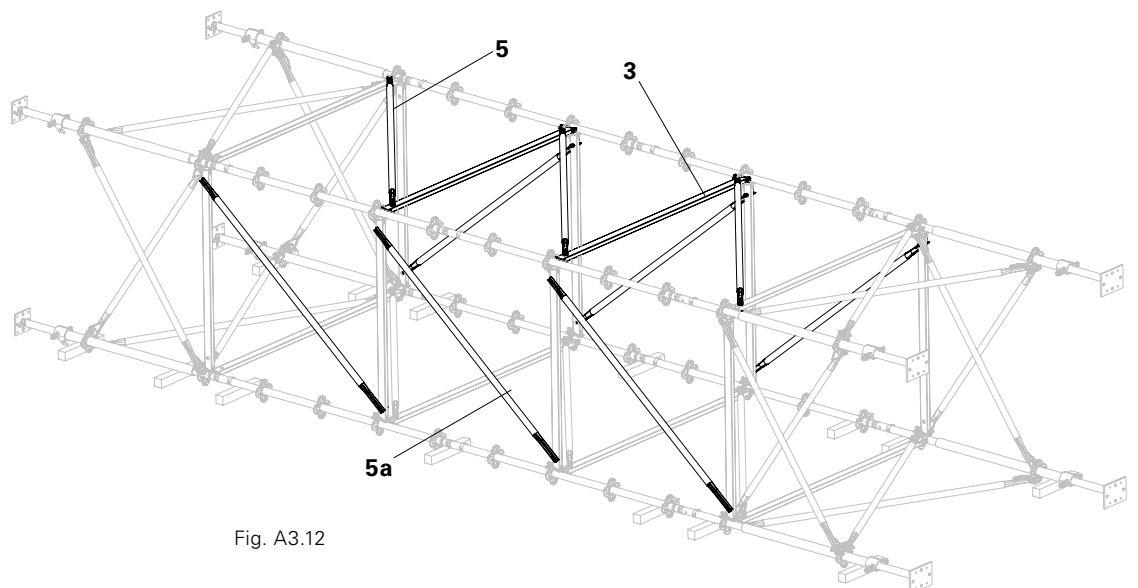

Fig. A3.12

Erection with the crane



- **Risk of injury from falling components!**
Ensure that all Standards are tightly connected!
- **Risk of falling!**
Remove the lifting gear from a safe working position!
- **Only attach to those rosette nodes which are directly connected to the Ledgers.**

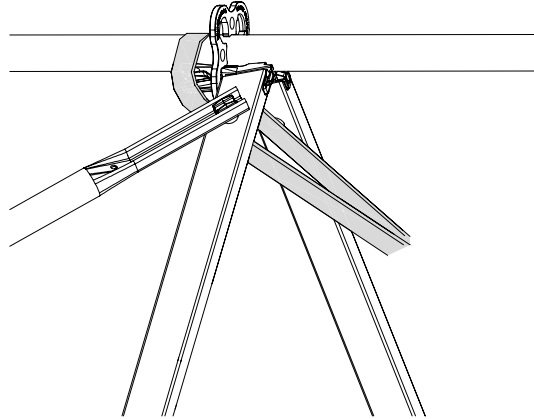

Fig. A3.13

Erection

1. Completely spindle in the bottom Adjustable Base Plates in order to prevent overloading the components during erection.
2. Place four chains or textile lifting slings, e.g. round slings, underneath those rosette nodes complete with Ledgers.
3. Erect shoring tower.
4. Whilst suspended on the crane lifting gear, adjust the Adj. Base Plates to the required height.

(Fig. A3.13 + A3.14)

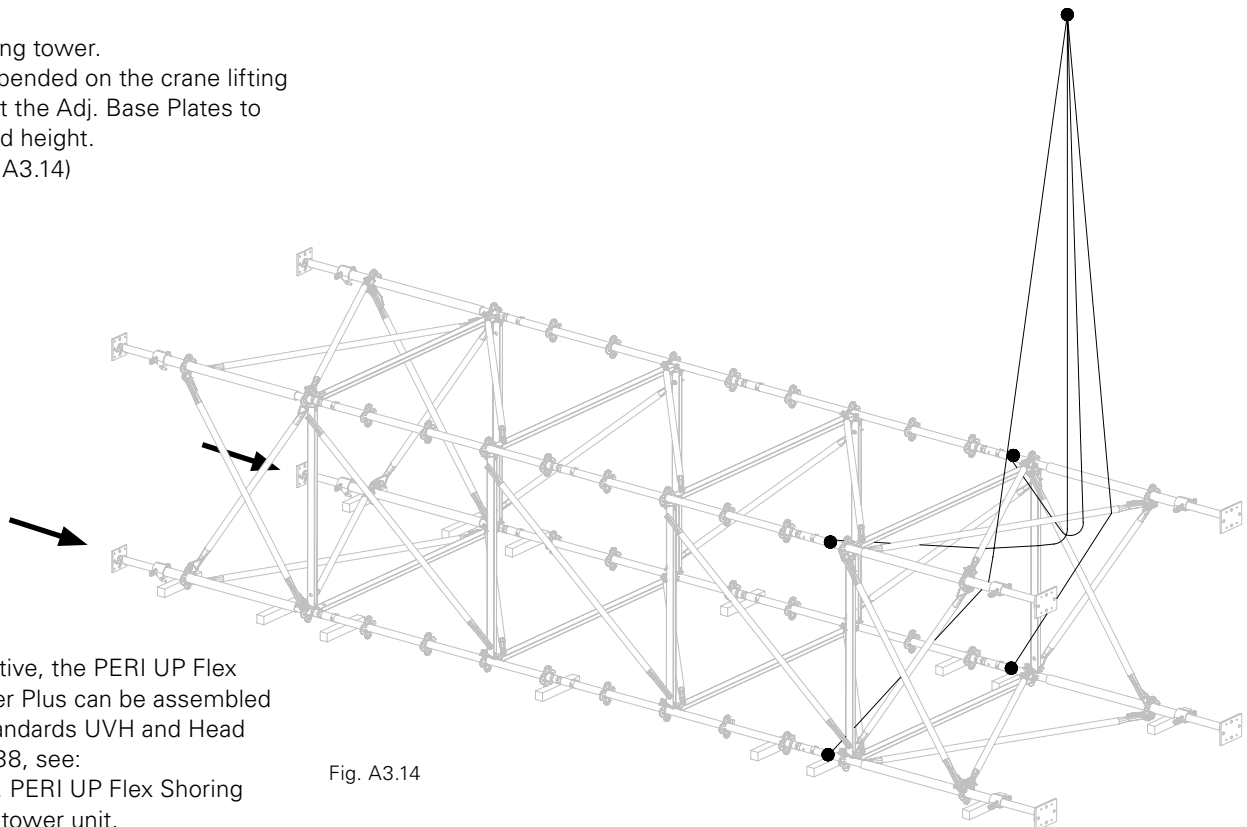

Fig. A3.14

Alternative

As an alternative, the PERI UP Flex Shoring Tower Plus can be assembled using Top Standards UVH and Head Spindles TR 38, see:

- Section A1, PERI UP Flex Shoring Tower, top tower unit.
- Load-bearing capacity table of permissible loads with TR 48 / 38.

Dismantling



- Risk of injury from falling components!
Ensure that all Standards are tightly connected!
- Risk of falling!
Attach the lifting gear from a safe working position!
- Only attach to those rosette nodes which are directly connected to the Ledgers.

Dismantling

1. Place four chains or textile lifting slings, e.g. round slings, underneath those rosette nodes complete with Ledgers, and attach to the crane lifting gear.
2. Completely spindle in the subsequent bottom Adjustable Base Plates in order to prevent overloading the components during setting down.
3. Using the wider side, position tower on support timbers with the crane.
4. Dismantle the tower beginning with the topmost frame:
 - Remove the top Base Element and dismantle it.
 - Remove each height unit one after the other. First dismantle the Ledger Braces and topmost Ledgers, and then the Standards.
 - Remove vertically positioned Ledgers.
 - Dismantle the bottom scaffold frame from the base side.
5. Store individual components accordingly, e.g. in pallets.

(Fig. A3.15)

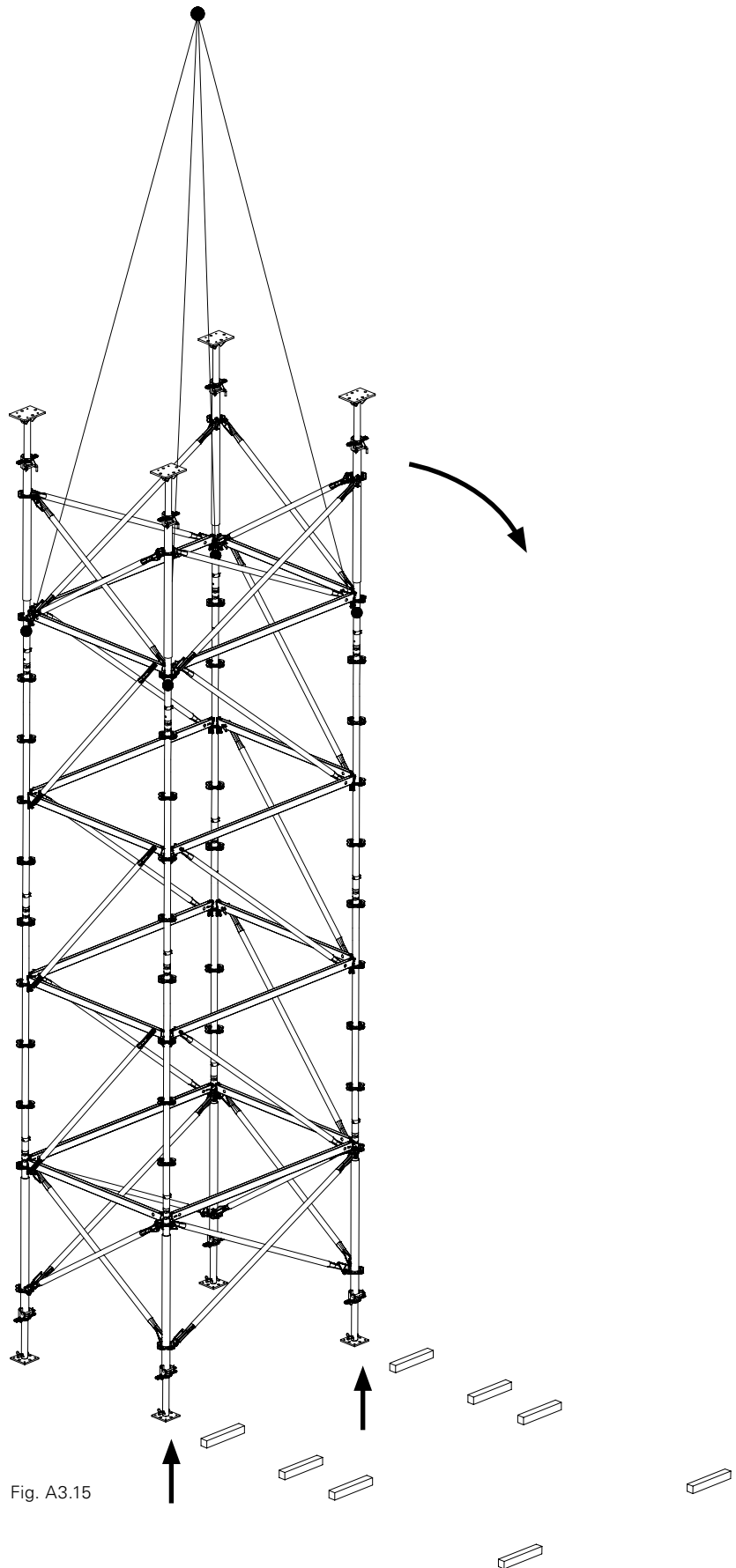

Fig. A3.15

Supporting individual towers



- To safeguard against falling over or horizontal movement, temporary support may be necessary during the installation process.
- Mount 3 Push-Pull Props as assembly aids.
- For high shoring towers, additional higher-positioned holders could be required.
- Alternatively, a corresponding holder on sufficiently load-bearing components already installed is possible.

| Components | Qty |
|---------------------------------|-----|
| 40 Push-Pull Prop RS | 3x |
| 41 Brace Connector HDR | 3x |
| 42 Base Plate RS | 3x |
| 43 Anchor Bolt PERI 14/20 x 130 | 3x |



Take into consideration the Data Sheet for Anchor Bolt PERI 14/20 x 130.

Preparation

Remove Cotter Pins (41.2) and Bolts (41.1) from the Brace Connectors (41).

Assembly

1. Secure coupling (41.3) of the Brace Connector (41) to the Standard of the shoring tower, and align. (Fig. A4.01a)
2. Insert lug (40.1) on the Push-Pull Prop (40) between the lugs of the Brace Connector.
3. Fix Push-Pull Prop with Bolts (41.1) and Cotter Pins (41.2) to the Brace Connector. (Fig. A4.01a)
4. Fix Base Plate (42) to the ground using Anchor Bolts (43). Inclination angle of the Push-Pull Prop to the ground approx. 60°. (Fig. A4.01b)
5. Fix Push-Pull Prop (40) to the Base Plate (42) using Bolts (42.1) and Cotter Pins (42.2). (Fig. A4.01b)

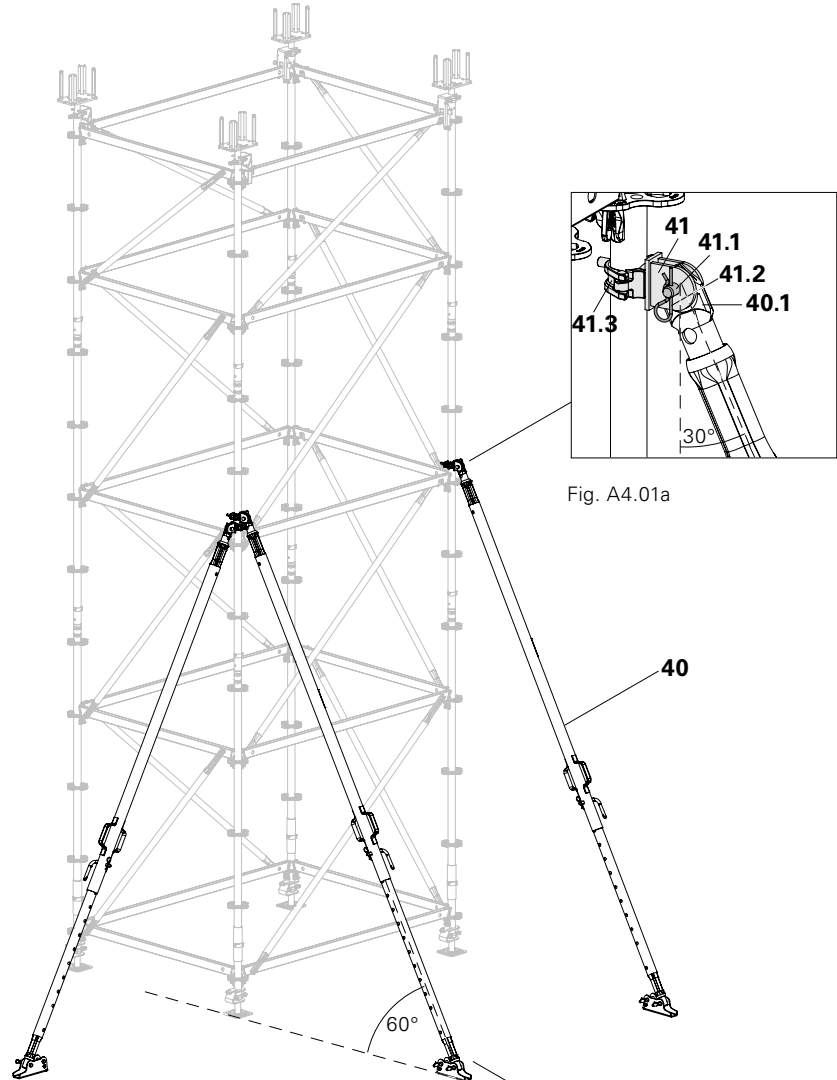

Fig. A4.01

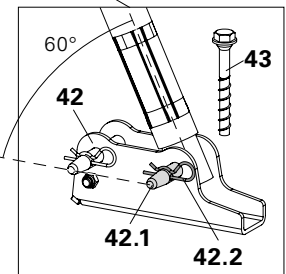

Fig. A4.01b

Bracing sets of shoring towers



For providing stability, mount Push-Pull Props and Ledgers.

Components

- 3 Ledger UH Plus
- 40 Push-Pull Prop RS
- 41 Brace Connector HDR
- 42 Base Plate RS
- 43 Anchor Bolt PERI 14/20 x 130

Number of pieces according to assembly instructions of the contractor.

Assembly

- Secure first shoring tower against tipping, see Supporting individual towers.
- Connect further shoring towers using Ledgers (3) and Push-Pull Props. (Fig. A5.02)



Alternatively, the shoring towers can also be secured against falling or horizontal movement during assembly operations using existing structural parts, e.g. walls.

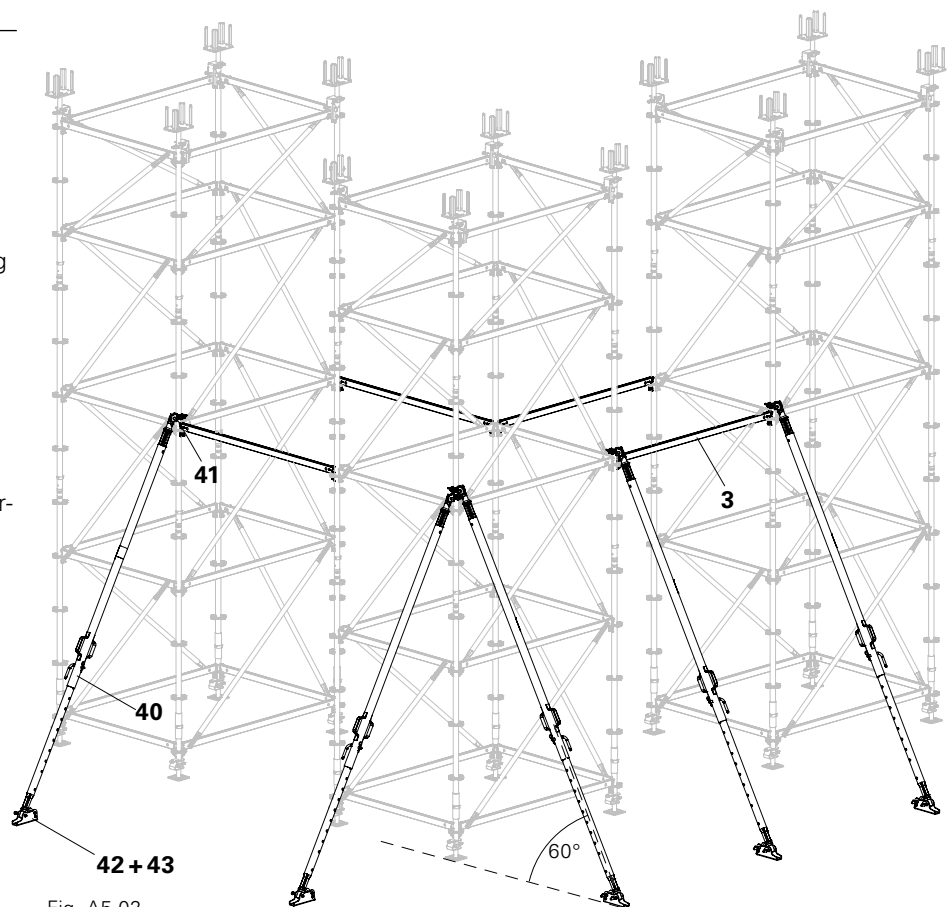
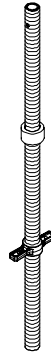

Fig. A5.02

Tower with Section Spindles

Section Spindles are used to further increase the load-bearing capacity of the PERI UP Flex Shoring Tower. The spindle extension of the Head Spindles and Adjustable Base Plates can be minimized in each case whereby rough height adjustment takes place via the Section Spindles. Fine adjustment takes place using the Head Spindles and Adjustable Base Plates.



Spindle extensions

Adj. Base Plate: max. 250 mm
Head Spindle: max. 200 mm



Application conditions

See Section Tables PERI UP Flex Shoring Tower with Spindle Section

Assembly

1. Assemble base unit as described in Section A1 PERI UP Flex Shoring Tower.
2. Position Top Standards (4a) on the Base Standards.
3. Connect the Top Standards with Ledgers (3).
4. Install Ledger Braces (5).
5. Place the Section Spindles (13) with Quick Jack Nuts on the Top Standards (4a) below, adjust the height and secure by means of Spindle Lockings (6).

(Fig. B1.01)

6. Install Base Standards (2) and secure by means of Locking Pins (7).
7. Insert Standards (4) in the Base Standards and brace using additional Ledgers (3a).

(Fig. B1.01a)

| Components* | Qty |
|--------------------------------------|-----|
| 2 Base Standard UVB 24 | 4x |
| 3 Ledger UH | 8x |
| 4a Top Standard UVH 150 | 4x |
| 6 Spindle Locking UJS | 4x |
| 7 Locking Pin Ø 48/57 | 4x |
| 13 Section Spindle UJK 38-110 | 4x |

*in addition to Section A1 PERI UP Flex Shoring Tower.

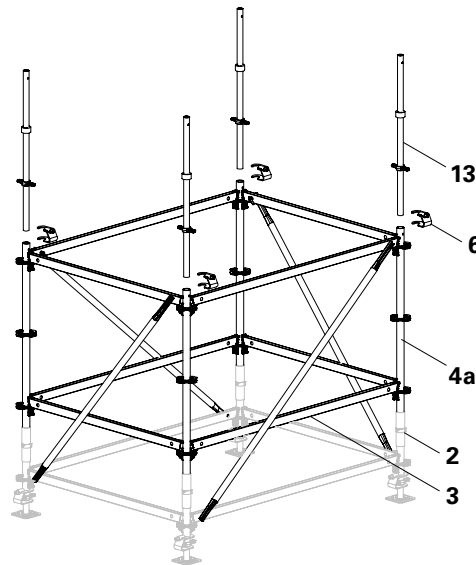

Fig. B1.01

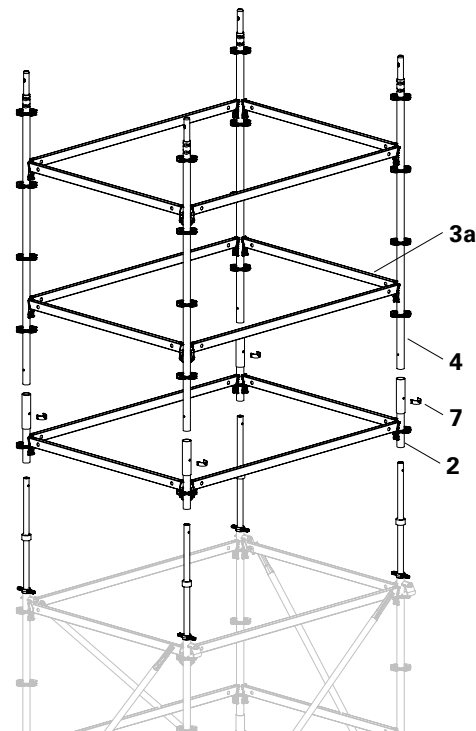

Fig. B1.01a

7. Complete assembly of the shoring tower as described in Section A1.
Fig. B1.01b

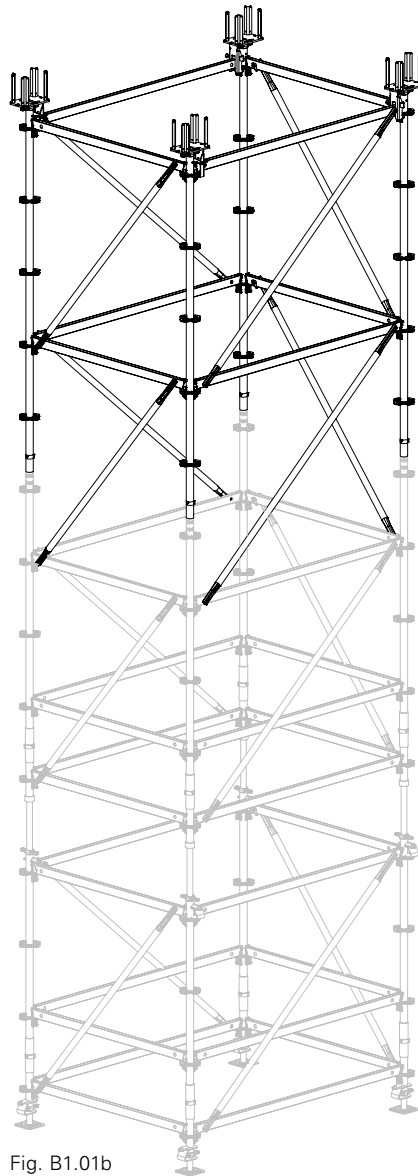

Fig. B1.01b

Additional Frames with Section Spindles

Assembly is carried out in the same way as for the shoring tower with Section Spindles.
(Fig. B1.02)

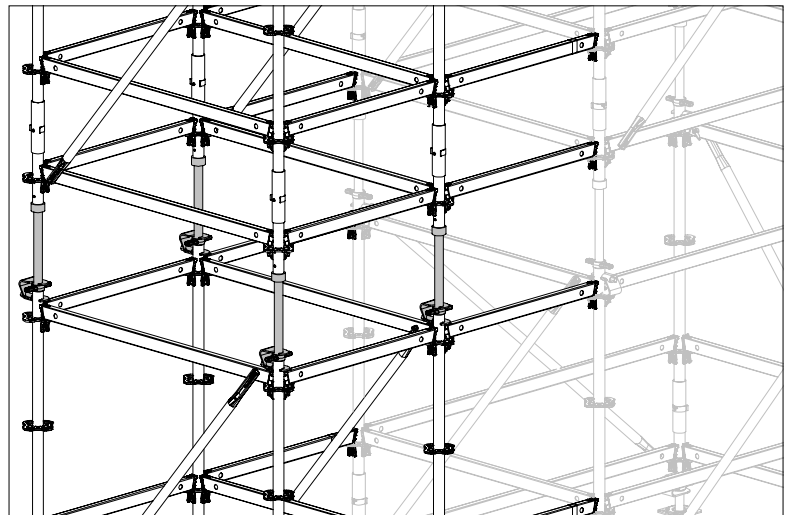

Fig. B1.02

Height extensions or reductions

Extending or reducing the height of the shoring tower is always useful if different supporting heights which are positioned one after the other are required. Completely dismantling and then re-assembling the tower is thus not necessary.

Shown here is the joining together of two individual towers.



Application conditions

See Section Tables PERI UP Flex Shoring Tower with Spindle Section.

| Components | Qty |
|-------------------------------|-----|
| 13 Section Spindle UJK 38-110 | 4x |

Assembly

1. Remove the Spindle Locking UJS and Head Spindle Locking UJH.
2. Remove the Head Spindles and Adjustable Base Plates (1, 11).
3. Place the Section Spindles (13) on the Top Standards (4a) and adjust the height.
4. Remove the Locking Pins (7) on the top tower.
5. Attach the second shoring tower unit on the Section Spindles.
6. Secure top Section Spindles (13) using Locking Pins (7). Secure bottom Section Spindle using Head Spindle Locking (12).

Fig. B1.03

For height reductions (the tower is divided into 2 units), the 4 Section Spindles are replaced:

- on the top tower unit through 4 Adjustable Base Plates,
- on the bottom tower unit through 4 Head Spindles.

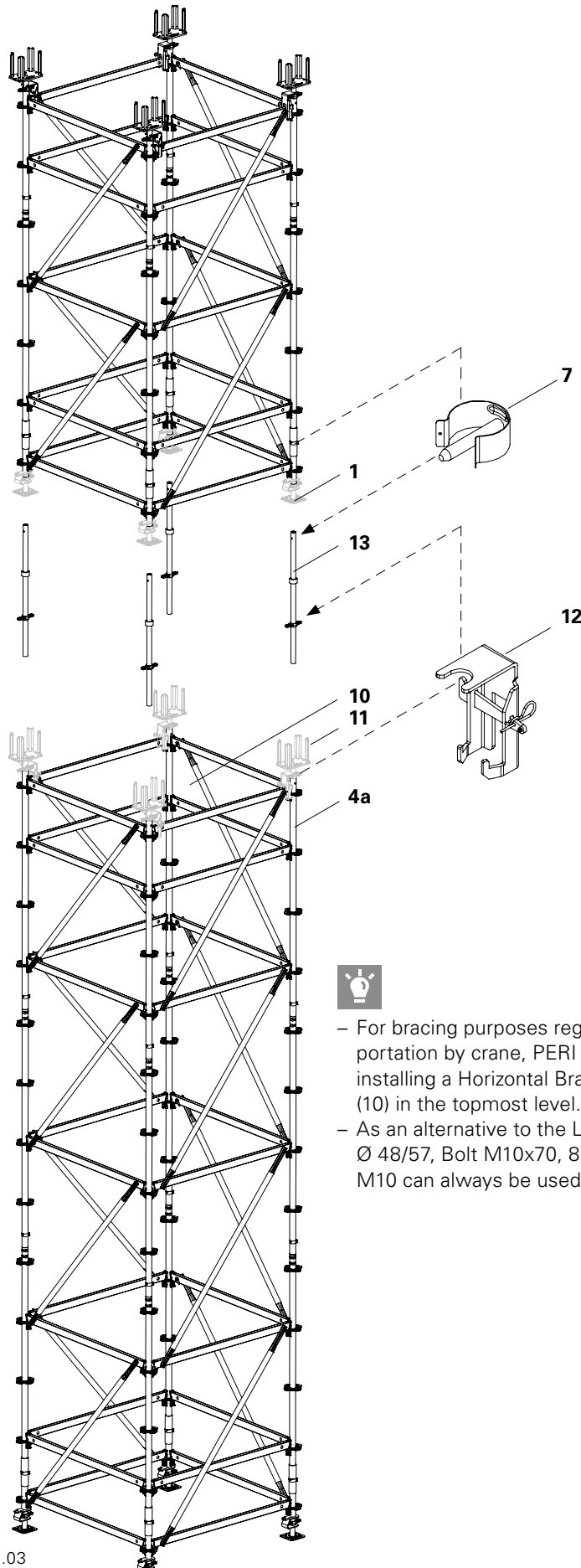

- For bracing purposes regarding transportation by crane, PERI recommends installing a Horizontal Brace UBH Flex (10) in the topmost level.
- As an alternative to the Locking Pin $\varnothing 48/57$, Bolt M10x70, 8.8 with Nut M10 can always be used.

Fig. B1.03

Transportation Wheel UEW

The Transportation Wheel UEW can be used for the PERI UP Flex Shoring Tower and PERI UP Flex Shoring Tower with VSS.

| Components | Qty |
|---|-----|
| 16 Transportation Wheel UEW | 4x |
| 17 Connection Transportation Wheel UER | 4x |

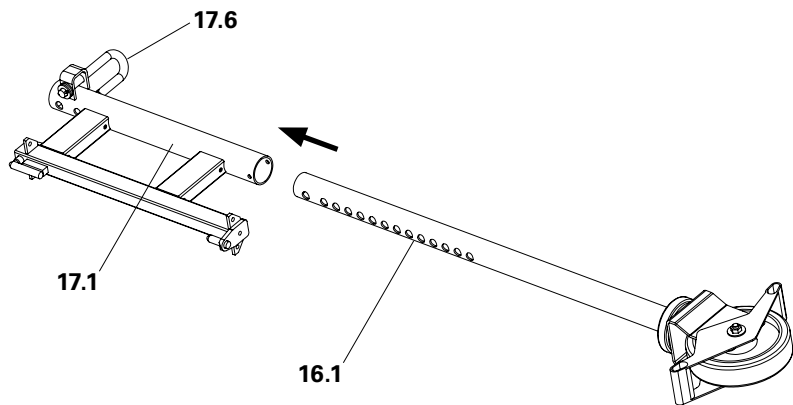

Pre-assembly

1. Completely insert the adjusting tube (16.1) of the Transportation Wheel UEW (16) into the guide tube (17.1) of the Connection Transportation Wheel UER (17).
2. Secure the adjusting tube with positioning pins (17.6).



Completely retract the Transportation Wheel!

Assembly

1. Insert Transportation Wheels with Spigots (17.2) from below into the rosettes. Insert the spigot first in the bottom rosette and then in the top rosette. Firmly hold the Transportation Wheels. (Fig. B1.04)
2. Insert locking lever (17.3) and turn downwards. Roll pin (17.4) must be fully engaged in the groove. (Fig. B1.04a – B1.04b)

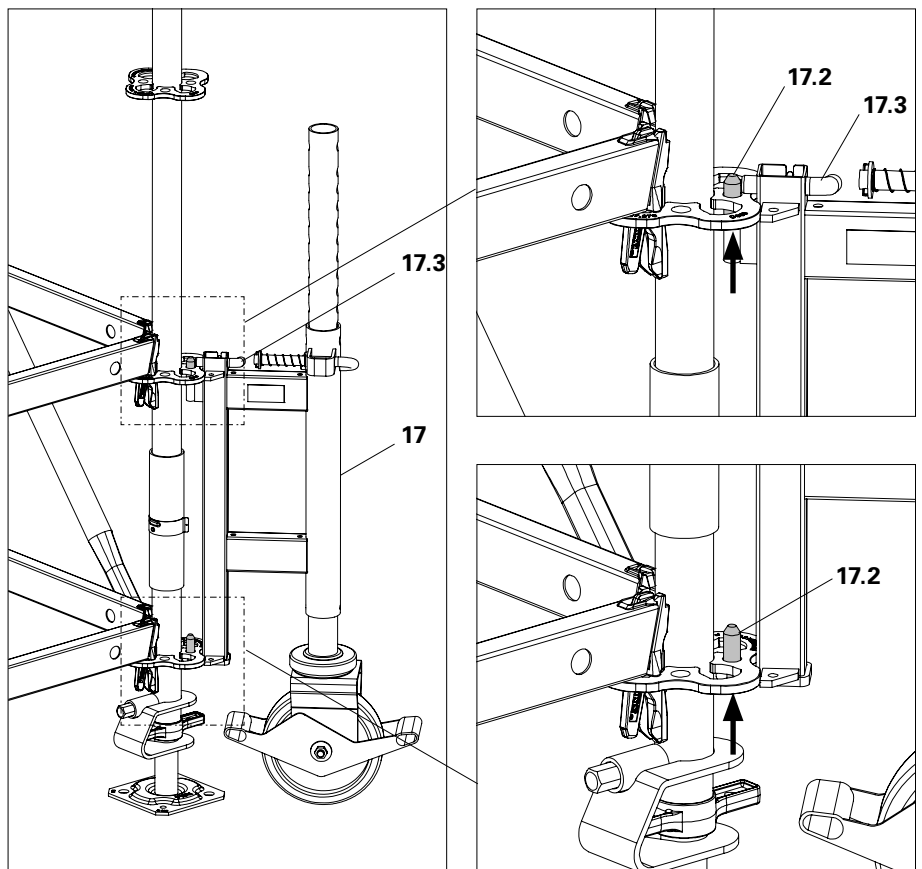

Fig. B1.04

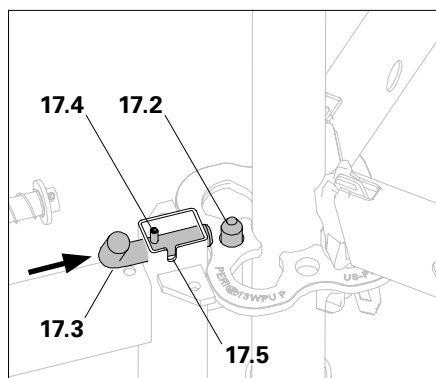

Fig. B1.04a

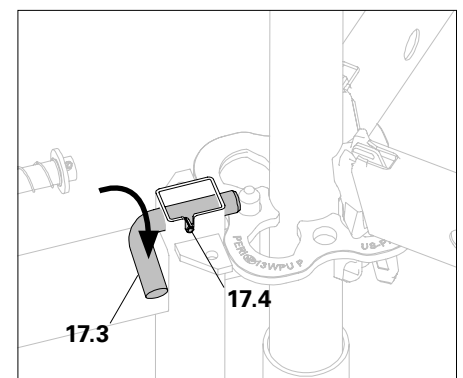

Fig. B1.04b

Moving the tower

1. Set down the Transportation Wheels UEW (16) completely on the ground, raise to the next pegging hole and peg with positioning pin (17.6). Secure positioning pin with cotter pins (17.7). (Fig. B1.04c - B1.04d)
2. Spindle in the Adjustable Base Plates of the shoring tower evenly until the dead weight of the shoring tower has been transferred to the Transportation Wheels and sufficient ground clearance has been achieved.
3. Horizontally move the shoring tower.
4. After the moving procedure, spindle out the Adjustable Base Plates of the shoring tower until the Transportation Wheels are free of any load.



Do not load the Transportation Wheels!

After the moving procedure, spindle out the Adjustable Base Plates again until the Transportation Wheels are completely free of any load.



The stability of the shoring tower against overturning must be guaranteed. Ratio $h/w < 3/1$ or in accordance with a separate verification.



Use positioning pins in the top or bottom hole depending on which hole is reached first.

Through the given hole pattern, the Transportation Wheel can be pegged in half-steps.

Dismantling the Transportation Wheels

The Transportation Wheels must be completely free of any load!

1. Completely retract the Transportation Wheel and peg.
 2. Hold the moving unit firmly, turn up the locking lever and pull out.
 3. Lower the moving unit until both bolts are out of the rosettes.
- The Transportation Wheel has now been dismantled.

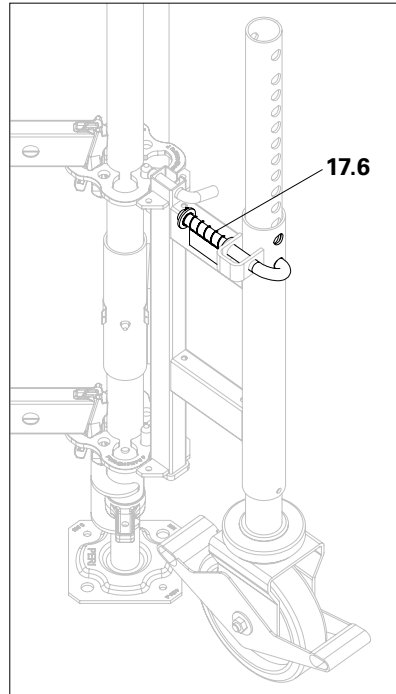

Fig. B1.04c

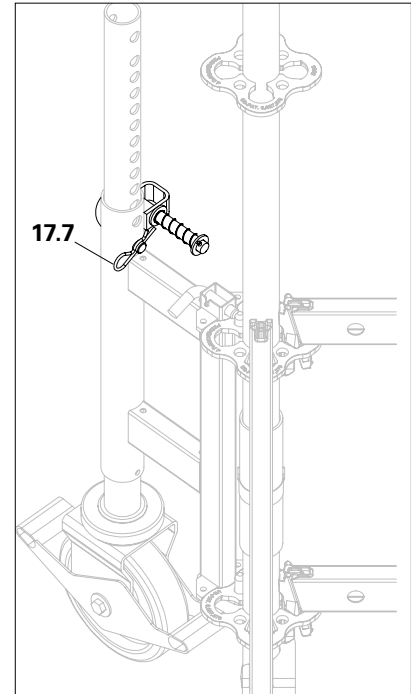

Fig. B1.04d

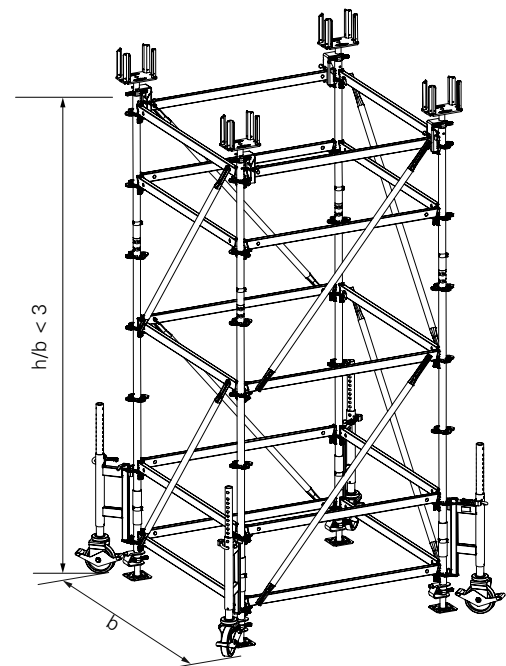

Fig. B1.04e

Trolley with Winch

The Trolley with Winch can be used for the PERI UP Flex Shoring Tower and PERI UP Flex Shoring Tower with VSS as well as PERI UP Flex Shoring Tower Plus.

| Components | Qty |
|-----------------------|-----|
| 18 PERI UP Trolley | 2x |
| 19 Trolley with Winch | 2x |

Trolley with Winch on PERI UP Flex Shoring Tower

Assembly

1. Mount the top connectors of the Trolley with Winch at the respective middle (18.1) and bottom (18.2) holes. The top hole (18.3) remains free. (Fig. B1.05)
2. For improved installation, the Ledger Braces of the shoring tower should be moved inside.
3. Move the Trolley with Winch against the shoring tower and raise the lifting device with the winch. Make sure that
 - the bottom connector (18.5) engages the rosette,
 - whilst the top connector (18.6) is positioned under the Ledger UH.
 → Lifting device secures automatically by means of a pivot lock.
6. Raise the lifting devices evenly until the dead weight of the shoring tower has been transferred to the Trolley with Winch and sufficient ground clearance has been achieved. (Fig. B1.05a – B1.05c)

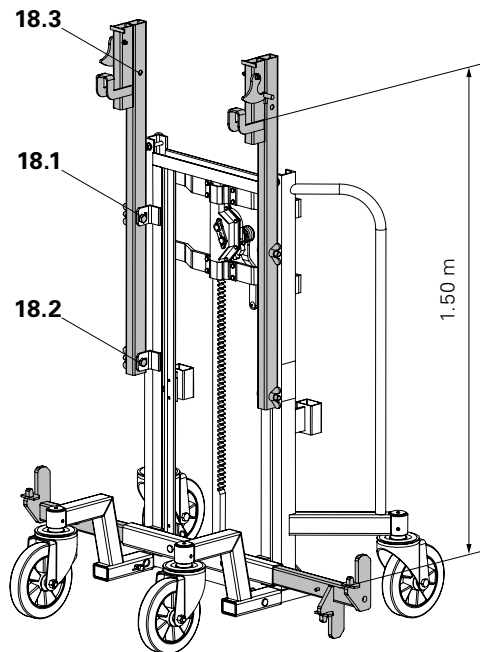

Fig. B1.05

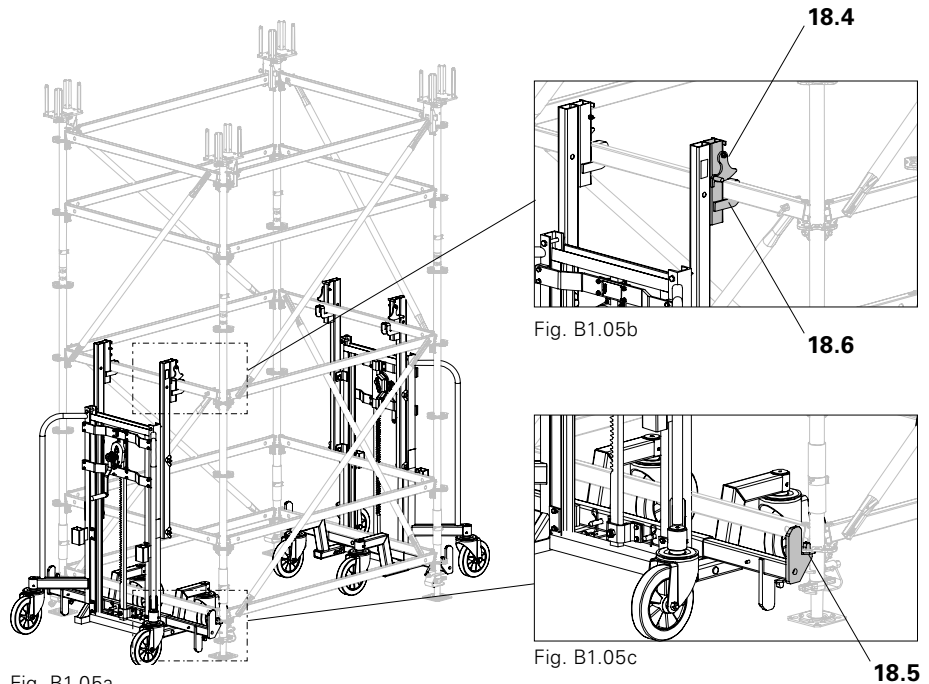

Fig. B1.05a

Fig. B1.05c



The stability of the shoring tower against overturning must be guaranteed. Ratio $h/w < 3/1$ or in accordance with a separate verification.



- Follow the Instructions for Use for the Trolley and Winch!
- Raise and lower the tower evenly.

Trolley with Winch on PERI UP Flex Shoring Tower with Additional Frame

Assembly takes place in the same way as for the PERI UP Flex Shoring Tower. For VSS with 25 cm, the following applies:



- For VSS with 25 cm spacing to the next frame, remove the bottom Ledger of the second frame.
- Check the clearance to the Ledger Braces (5)! (Fig. B1.06 – B1.07)
- After the moving procedure has finished, re-install the Ledger!

Assembly

See Section Trolley with Winch on PERI UP Flex Shoring Tower.

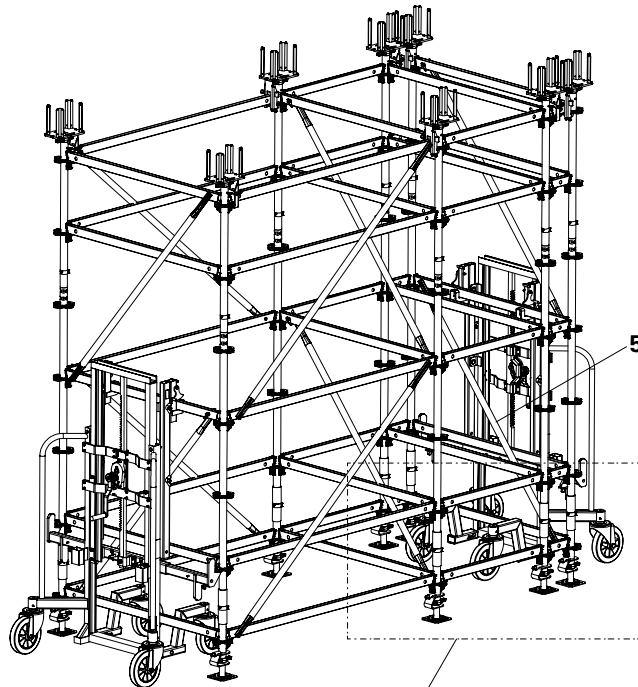

Fig. B1.06

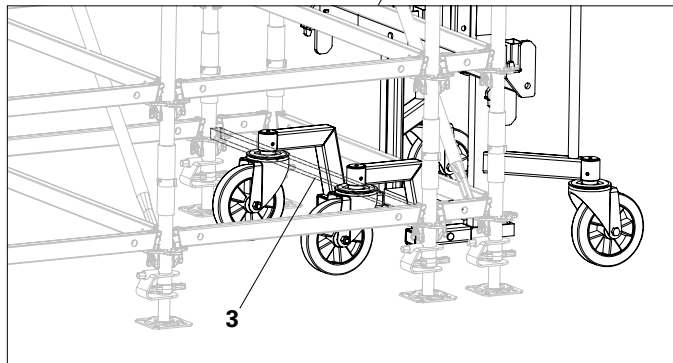

Fig. B1.07

Trolley with Winch on PERI UP Flex Shoring Tower Plus

Assembly

1. Mount the top connector of the Trolley with Winch at the respective top (18.3) and middle (18.1) holes. The bottom hole (18.2) remains free. (Fig. B1.08 – B1.08c)

Additional assembly: see Section Trolley with Winch on PERI UP Flex Shoring Tower.

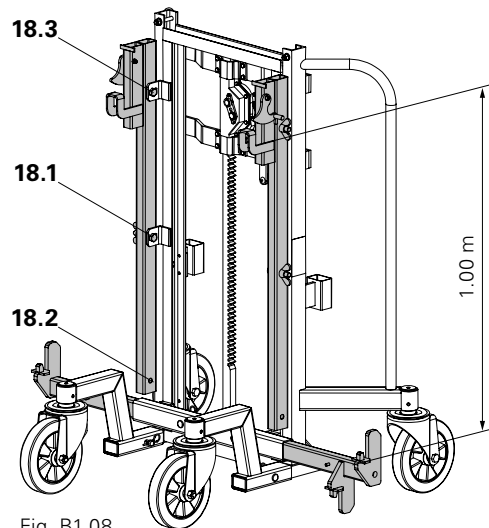

Fig. B1.08

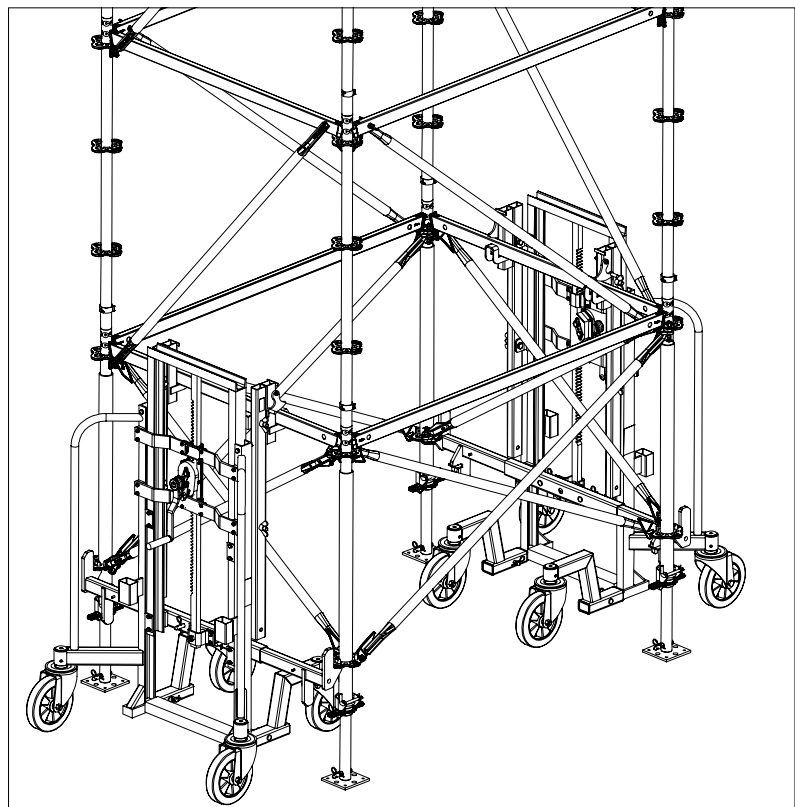

Fig. B1.08a

Inclined erection areas, inclined slab decks

The PERI UP Flex Shoring Tower can be adjusted to accommodate inclined erection areas or inclined slab decks.

The longer side of the shoring tower must point in the direction of the inclination.



Risk of collapse!

- All occurring horizontal forces must be safely transferred.
- Separate static proof is required for use on inclined erection areas or under inclined slabs.



The pegging holes to be used on the Connector MP/SRU are determined by the angle of inclination.

Components

- 53 Spindle Head SRU
- 54 Connector MP/SRU
- 55 Fitting Pin $\varnothing 21 \times 120$
- 56 Cotter Pin 6/1
- 57 Swivel Coupling DK 38/48
- 58 Swivel Coupling DK 48/48

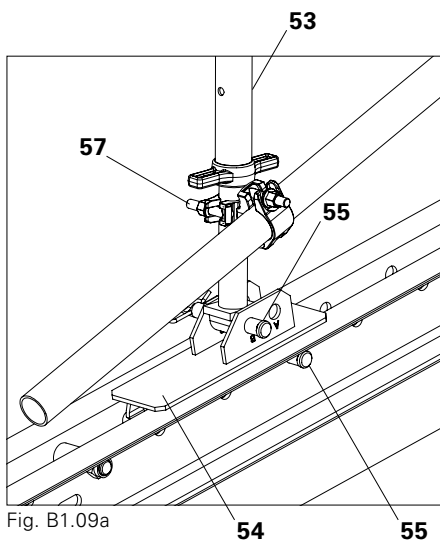

Fig. B1.09a

Assembly on inclined erection areas

1. Align the Steel Waler SRU to accommodate the slope. Secure the Steel waler to prevent slipping, e.g. by anchoring into the ground.
2. Mount Connector MP/SRU (54) on the Steel Waler SRU using Fitting Pins (55). Secure Fitting Pins with Cotter Pins (56).
3. As Adjustable Base Plates, mount Spindle Head SRU (53) to the Connector MP/SRU using Fitting Pins (55) and Cotter Pins (56).
4. Insert Spindle Head SRU (53) in the Base Standard (2) and secure by means of the Spindle Locking UJS (6).
5. Set up Standards (4) which have been adapted to accommodate the inclination and brace with Ledgers (3) at the first level of rosettes.
6. Horizontally align the assembly.
7. Diagonally brace the longer Standards with scaffold tubes between the Spindle Head SRU and Standard UVR. For this, mount a Swivel Coupling DK 38/48 (57) on the Spindle Head, as close as possible to the Connector MP/SRU. Mount a Swivel Coupling DK 48/48 (58) on the Standard directly above the first rosette.
8. Erection of the shoring tower continues in accordance with Section A1. (Fig. B1.09 – B1.09a)

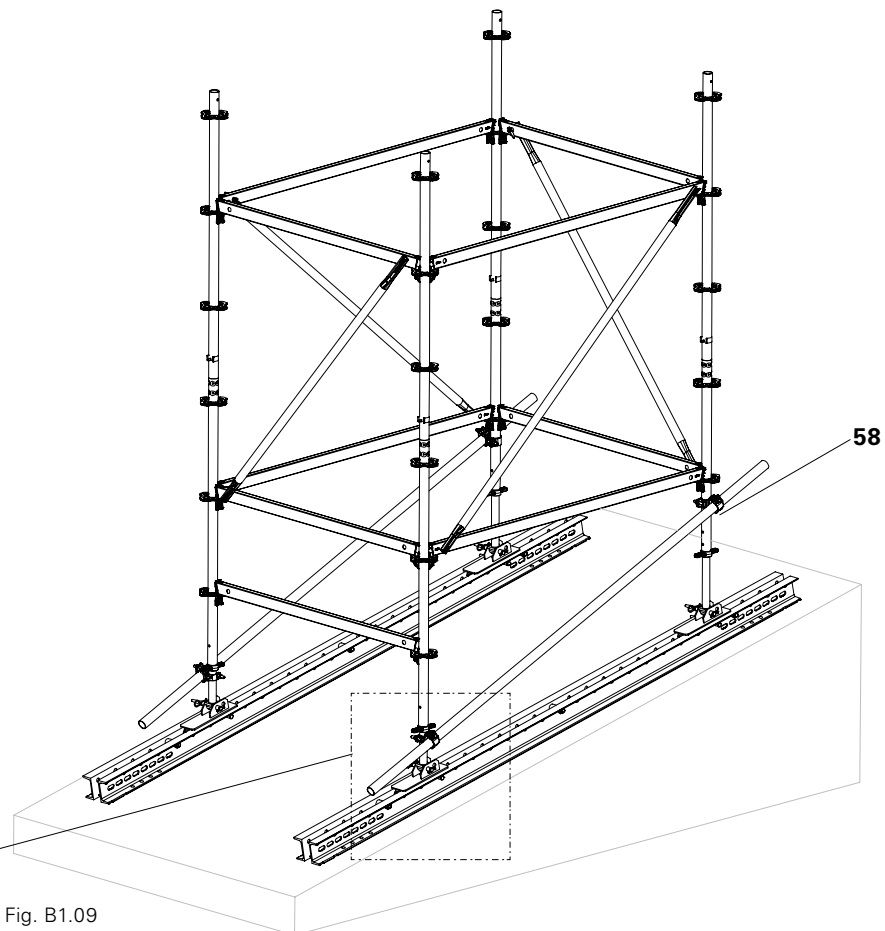

Fig. B1.09

Assembly under inclined slab decks

1. Assemble the shoring tower up to the head section according to Section A1.
2. Set up Top Standards (4a) which have been adapted to accommodate the inclination and brace with Ledgers (3) at the top level of rosettes.
3. As Head Spindles, insert Spindle Head SRU (53) in the Top Standards and secure using the Spindle Locking UJS (6).
4. Diagonally brace the longer Standards with scaffold tubes between the Spindle Head SRU and Standard UVR (4). For this, mount a Swivel Coupling DK 38/48 (57) on the Spindle Head, as close as possible to the Connector MP/SRU. Mount a Swivel Coupling DK 48/48 (58) on the Standard directly under the first rosette.
5. Mount Connector MP/SRU (54) on the Spindle Head SRU using Fitting Pins (55) and Cotter Pins (56).
6. Mount Connector MP/SRU on the Steel Waler SRU using Fitting Pins. Secure Fitting Pins with Cotter Pins (56).
7. Safely transfer horizontal loads as directly as possible, e.g. via the bracing on the Steel Waler SRU.

(Fig. B1.10 – B1.10a)

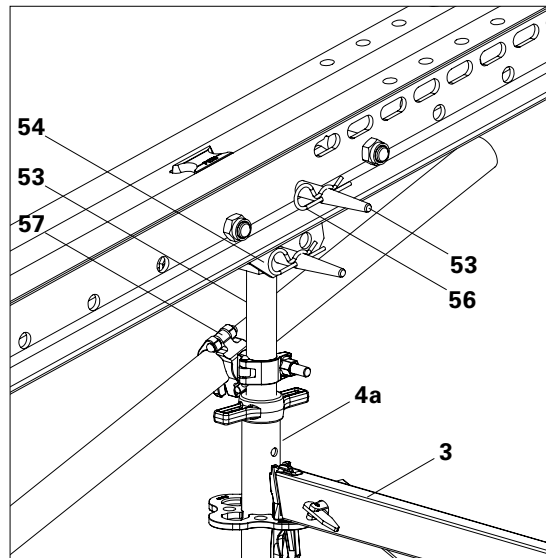

Fig. B1.10a

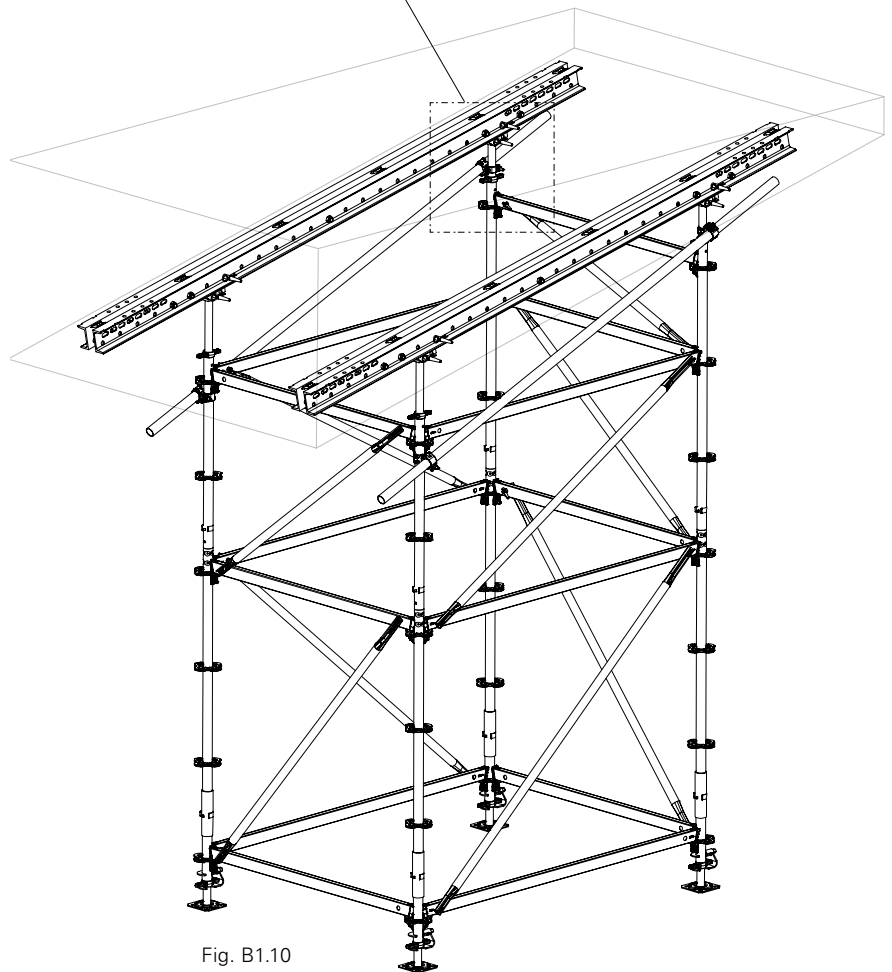

Fig. B1.10



- **Instructions for Use for PERI pallets and stacking devices must be followed at all times!**
- **Pallets and stacked items are to be protected against the effects of the weather!**
- **Always attach the 4-sling lifting gear using the four load-bearing points!**

Transport

PERI pallets and stacking devices are suitable for lifting by crane or forklift. They can also be moved with the PERI Pallet Lifting Trolley. All pallets and stacking devices can be lifted using both the longitudinal and front sides. The illustrations show examples.

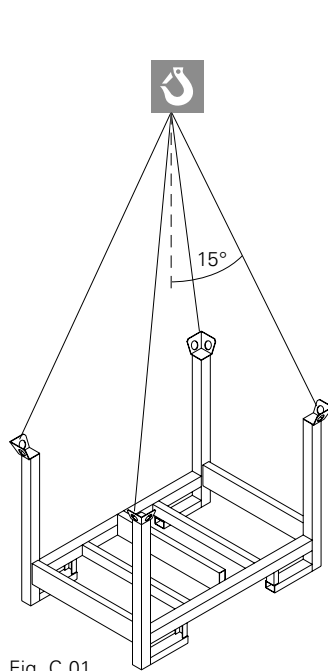

Fig. C.01

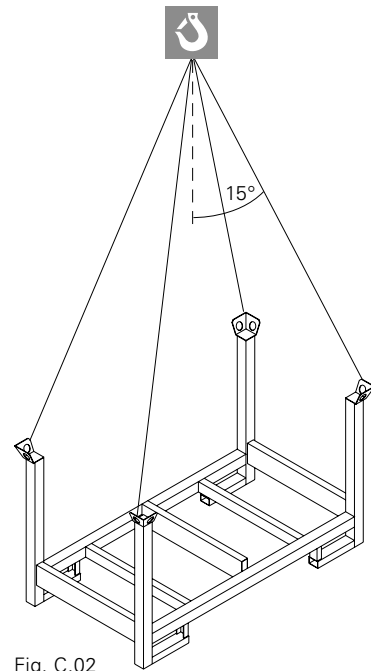

Fig. C.02

Pallet RP-2 80 x 120

(Fig. C.01)

Pallet RP-2 80 x 150

(Fig. C.02)

Load-bearing capacity = 1.5 t.
Crane sling angle $\leq 15^\circ$ from the vertical.
Stacking height: 4 pallets on top of each other.

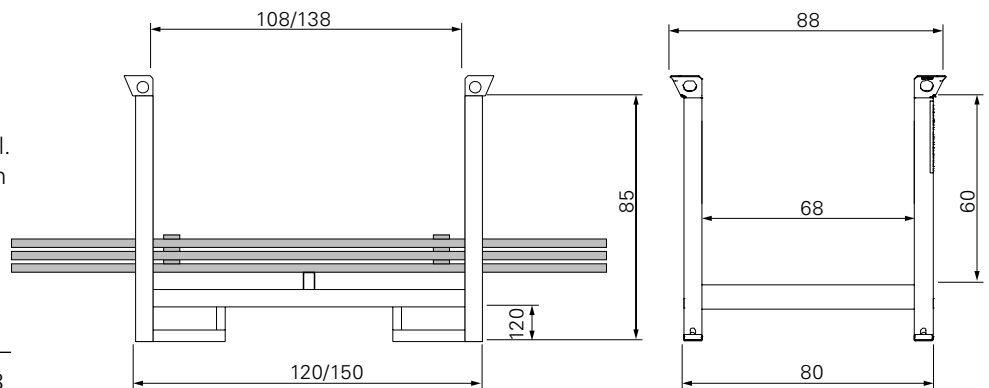

Fig. C.02a

Storage examples

Pallet RP-2 80 x 120

| | | |
|-----------|----------------------------|-----|
| 3 | Ledger UH Plus | 108 |
| 5c | Ledger Brace UBL 150/100 | 225 |
| 25 | Base Standard UVB 135 Plus | 48 |
| 28 | Top Standard UVH 165 Plus | 48 |

(Fig. C.03)

Pallet RP-2 80 x 150

| | | |
|-----------|---------------------------|-----|
| 4 | Standard UVR 200 | 56 |
| 10 | H-Braces UBH Flex 200/150 | 104 |
| 3a | Ledger UH Plus 200 | 48 |
| 5b | Ledger Brace UBL 200/100 | 48 |

(Fig. C.04)

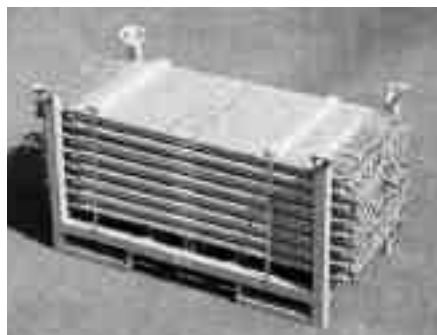

Fig. C.03



Fig. C.04



- Always attach the 4-sling lifting gear using the four load-bearing points!
- Before transporting, close and lock the flap and, if necessary, secure the cover!

Pallet Cage 80 x 120

(Fig. C.05 + C.05a)

Load-bearing capacity = 1.5 t.

Crane sling angle $\leq 15^\circ$.

Stacking height: 3 pallet cages on top of each other.

Storage examples

Pallet RP-2 80 x 120

| | | |
|-----------|------------------------------------|-----|
| 1 | Cross Forkhead TR 38-70/50 | 40 |
| 5a | Adjustable Base Plate UJB 38-50/30 | 200 |

(Fig. C.06)



For better loading and unloading, the flap (52) can be pivoted downwards.

For securing the load against theft, the crate pallet can be optionally fitted with a cover.

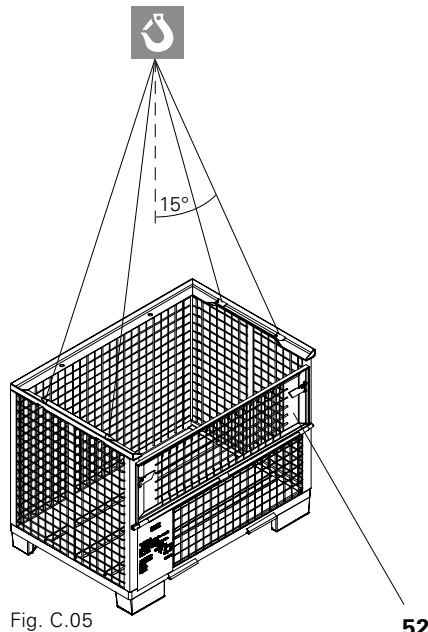

Fig. C.05

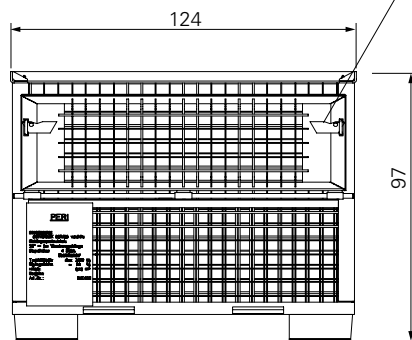

Fig. C.05a

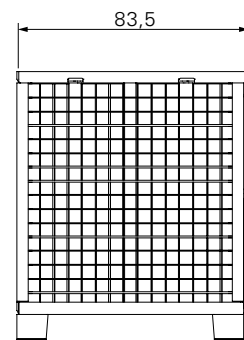

Fig. C.06

PERI UP Rosett Shoring Tower

Restrained at the top, $h \leq 21.89$ m

Application conditions

- Restrained at the top
- Without additional ledgers in top and bottom sections
- Horizontal cross strut min. every 9 m
- Head Spindle or Cross Forkhead
- $h \leq 21.89$ m

Ground plan

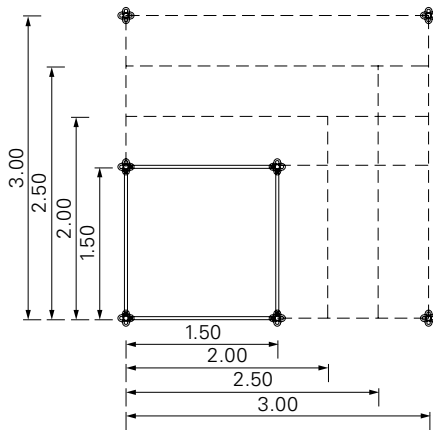

Head Spindle or
Cross Forkhead
TR 38 – 70 / 50

Adj. Base Plate
UJB 38 – 50 / 30

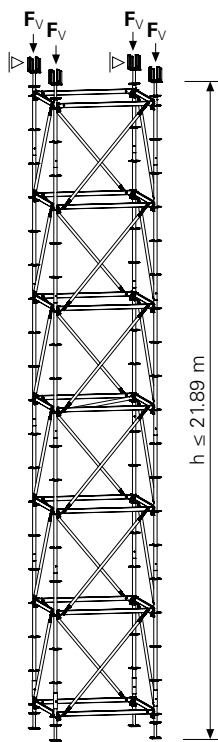

Perm. leg load

| h [m] | F _V [kN] | | | | | | | | | |
|----------------|---------------------|------|------|-------|------|------|-------|------|-------|------|
| | Ground plan [m] | | | | | | | | | |
| | 1.5 x | | | 2.0 x | | | 2.5 x | | 3.0 x | |
| | 1.5 | 2.0 | 2.5 | 3.0 | 2.0 | 2.5 | 3.0 | 2.5 | 3.0 | 3.0 |
| q = 0.5 | | | | | | | | | | |
| 1.83 - 8.39 | 34.4 | | | | | | | | | |
| 8.33 - 8.89 | 33.9 | 33.1 | 32.4 | 31.6 | 33.7 | 33.1 | 32.4 | 33.8 | 33.2 | 34.0 |
| 8.83 - 9.39 | 33.6 | 32.8 | 32.0 | 31.2 | 33.4 | 32.7 | 32.0 | 33.3 | 32.8 | 33.5 |
| 9.33 - 9.89 | 33.2 | 32.4 | 31.6 | 30.7 | 33.0 | 32.2 | 31.5 | 32.9 | 32.3 | 33.1 |
| 9.83 - 10.39 | 32.9 | 32.0 | 31.1 | 30.3 | 32.6 | 31.8 | 31.0 | 32.5 | 31.8 | 32.6 |
| 10.33 - 10.89 | 32.6 | 31.7 | 30.7 | 29.8 | 32.2 | 31.4 | 30.6 | 32.1 | 31.3 | 32.1 |
| 10.83 - 11.39 | 32.3 | 31.3 | 30.3 | 29.3 | 31.9 | 31.0 | 30.1 | 31.6 | 30.9 | 31.6 |
| 11.33 - 11.89 | 32.0 | 30.9 | 29.9 | 28.9 | 31.5 | 30.6 | 29.6 | 31.2 | 30.4 | 31.1 |
| 11.83 - 12.39 | 31.6 | 30.6 | 29.5 | 28.4 | 31.1 | 30.1 | 29.2 | 30.8 | 29.9 | 30.7 |
| 12.33 - 12.89 | 31.3 | 30.2 | 29.1 | 28.0 | 30.7 | 29.7 | 28.7 | 30.4 | 29.4 | 30.2 |
| 12.83 - 13.39 | 31.0 | 29.8 | 28.7 | 27.5 | 30.4 | 29.3 | 28.2 | 29.9 | 29.0 | 29.7 |
| 13.33 - 13.89 | 30.7 | 29.5 | 28.3 | 27.0 | 30.0 | 28.9 | 27.8 | 29.5 | 28.5 | 29.2 |
| 13.83 - 14.39 | 30.4 | 29.1 | 27.8 | 26.6 | 29.6 | 28.5 | 27.3 | 29.1 | 28.0 | 28.7 |
| 14.33 - 14.89 | 30.0 | 28.7 | 27.4 | 26.1 | 29.2 | 28.0 | 26.8 | 28.7 | 27.5 | 28.3 |
| 14.83 - 15.39 | 29.7 | 28.4 | 27.0 | 25.7 | 28.9 | 27.6 | 26.4 | 28.2 | 27.1 | 27.8 |
| 15.33 - 15.89 | 29.4 | 28.0 | 26.6 | 25.2 | 28.5 | 27.2 | 25.9 | 27.8 | 26.6 | 27.3 |
| 15.83 - 16.39 | 29.2 | | | | | | | | | |
| 16.33 - 16.89 | 28.9 | | | | | | | | | |
| 16.83 - 17.39 | 28.7 | | | | | | | | | |
| 17.33 - 17.89 | 28.4 | | | | | | | | | |
| 17.83 - 18.39 | 28.2 | | | | | | | | | |
| 18.33 - 18.89 | 27.9 | | | | | | | | | |
| 18.83 - 19.39 | 27.7 | | | | | | | | | |
| 19.33 - 19.89 | 27.4 | | | | | | | | | |
| 19.83 - 20.39 | 27.2 | | | | | | | | | |
| 20.33 - 20.89 | 27.0 | | | | | | | | | |
| 20.83 - 21.39 | 26.7 | | | | | | | | | |
| 21.33 - 21.89 | 26.5 | | | | | | | | | |

Dynamic pressure [kN/m²] q = 0.8

For this area, please refer to Appendices T1 + T2 of the type test.

| F _V [kN] |
|---------------------|
| all ground plans |
| 38.0 |
| 37.9 |
| 37.8 |
| 37.7 |
| 37.6 |
| 37.5 |
| 37.4 |
| 37.3 |
| 37.2 |
| 37.1 |
| 37.0 |
| 36.9 |
| 36.8 |
| 36.7 |
| 36.6 |
| 36.5 |
| 36.5 |
| 36.4 |
| 36.4 |
| 36.4 |
| 36.3 |
| 36.3 |
| 36.3 |
| 36.2 |
| 36.2 |
| 36.2 |
| 36.1 |
| 36.1 |

without wind, q = 0

PERI UP Rosett Shoring Tower

Restrained at the top, $h \leq 21.89$ m, with additional ledger



Application conditions

- Restrained at the top
- With additional ledgers in top and bottom sections
- Horizontal cross strut min. every 9 m
- Head Spindle or Cross Forkhead
- $h \leq 21.89$ m

Ground plan

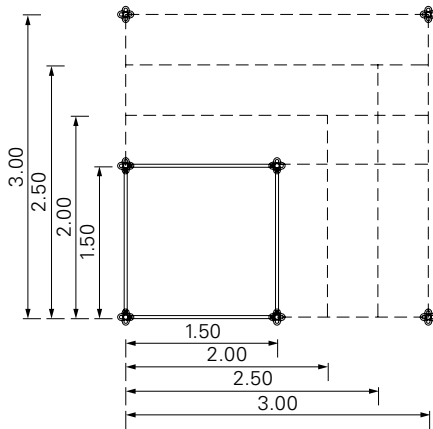

Head Spindle or
Cross Forkhead
TR 38 – 70 / 50

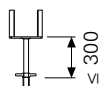

Adj. Base Plate
UJB 38 – 50 / 30

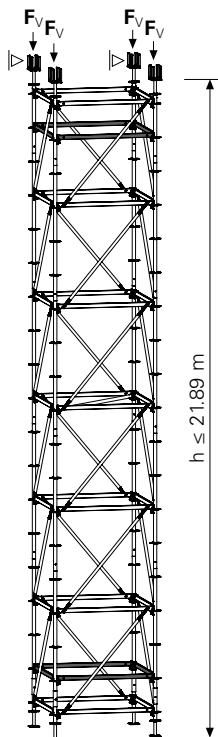

Perm. leg load

| h [m] | F_V [kN] | | | | | | | | | | | |
|--|-----------------|------|--|-------|------|------|-------|------|-------|------|------|--|
| | Ground plan [m] | | | | | | | | | | | |
| | 1.5 x | | | 2.0 x | | | 2.5 x | | 3.0 x | | | |
| | 1.5 | 2.0 | 2.5 | 3.0 | 2.0 | 2.5 | 3.0 | 2.5 | 3.0 | 3.0 | | |
| q = 0.5 | 1.83 - 8.39 | 39.9 | | | | | | | | | | |
| | 8.33 - 8.89 | 38.5 | 37.7 | 37.0 | 36.2 | 37.9 | 37.3 | 36.6 | 37.6 | 37.1 | 37.5 | |
| Dynamic pressure [kN/m²] q = 0.8 | 8.83 - 9.39 | 38.1 | 37.3 | 36.5 | 35.7 | 37.5 | 36.9 | 36.2 | 37.2 | 36.6 | 37.0 | |
| | 9.33 - 9.89 | 37.8 | 36.9 | 36.1 | 35.3 | 37.2 | 36.4 | 35.7 | 36.8 | 36.2 | 36.6 | |
| | 9.83 - 10.39 | 37.4 | 36.6 | 35.7 | 34.8 | 36.8 | 36.0 | 35.2 | 36.4 | 35.7 | 36.2 | |
| | 10.33 - 10.89 | 37.1 | 36.2 | 35.2 | 34.3 | 36.4 | 35.6 | 34.8 | 36.0 | 35.3 | 35.7 | |
| | 10.83 - 11.39 | 36.8 | 35.8 | 34.8 | 33.8 | 36.0 | 35.2 | 34.3 | 35.6 | 34.8 | 35.3 | |
| | 11.33 - 11.89 | 36.4 | 35.4 | 34.4 | 33.3 | 35.6 | 34.8 | 33.8 | 35.2 | 34.4 | 34.9 | |
| | 11.83 - 12.39 | 36.1 | 35.0 | 33.9 | 32.9 | 35.3 | 34.3 | 33.4 | 34.7 | 33.9 | 34.4 | |
| | 12.33 - 12.89 | 35.7 | 34.6 | 33.5 | 32.4 | 34.9 | 33.9 | 32.9 | 34.3 | 33.5 | 34.0 | |
| | 12.83 - 13.39 | 35.4 | 34.2 | 33.1 | 31.9 | 34.5 | 33.5 | 32.4 | 33.9 | 33.0 | 33.6 | |
| | 13.33 - 13.89 | 35.1 | 33.8 | 32.6 | 31.4 | 34.1 | 33.1 | 32.0 | 33.5 | 32.6 | 33.1 | |
| | 13.83 - 14.39 | 34.7 | 33.5 | 32.2 | 30.9 | 33.7 | 32.7 | 31.5 | 33.1 | 32.1 | 32.7 | |
| | 14.33 - 14.89 | 34.4 | 33.1 | 31.8 | 30.5 | 33.4 | 32.2 | 31.0 | 32.7 | 31.7 | 32.3 | |
| | 14.83 - 15.39 | 34.0 | 32.7 | 31.3 | 30.0 | 33.0 | 31.8 | 30.6 | 32.3 | 31.2 | 31.8 | |
| | 15.33 - 15.89 | 33.7 | 32.3 | 30.9 | 29.5 | 32.6 | 31.4 | 30.1 | 31.9 | 30.8 | 31.4 | |
| | 15.83 - 16.39 | 33.4 | For this area, please refer to Appendices T3 + T4 of the type test. | | | | | | | | | |
| | 16.33 - 16.89 | 33.2 | | | | | | | | | | |
| | 16.83 - 17.39 | 32.9 | | | | | | | | | | |
| | 17.33 - 17.89 | 32.6 | | | | | | | | | | |
| | 17.83 - 18.39 | 32.4 | | | | | | | | | | |
| | 18.33 - 18.89 | 32.1 | | | | | | | | | | |
| 18.83 - 19.39 | 31.8 | | | | | | | | | | | |
| 19.33 - 19.89 | 31.6 | | | | | | | | | | | |
| 19.83 - 20.39 | 31.3 | | | | | | | | | | | |
| 20.33 - 20.89 | 31.0 | | | | | | | | | | | |
| 20.83 - 21.39 | 30.8 | | | | | | | | | | | |
| 21.33 - 21.89 | 30.5 | | | | | | | | | | | |

| F_V [kN] |
|------------------|
| all ground plans |
| 41.6 |
| 41.5 |
| 41.4 |
| 41.3 |
| 41.2 |
| 41.1 |
| 41.0 |
| 40.9 |
| 40.8 |
| 40.7 |
| 40.6 |
| 40.5 |
| 40.4 |
| 40.3 |
| 40.2 |
| 40.1 |
| 40.1 |
| 40.1 |
| 40.1 |
| 40.0 |
| 40.0 |
| 40.0 |
| 40.0 |
| 40.0 |
| 39.9 |
| 39.9 |
| 39.9 |
| 39.8 |
| 39.8 |

without wind, q = 0

PERI UP Rosett Shoring Tower

Free standing, 1.5 m x 1.5 m, $h \leq 8.39$ m, with additional ledger



Application conditions

- Free standing
- With wind
- With additional ledgers in top and bottom sections
- Head Spindle or Cross Forkhead
- height $h \leq 8.39$ m

Perm. leg load

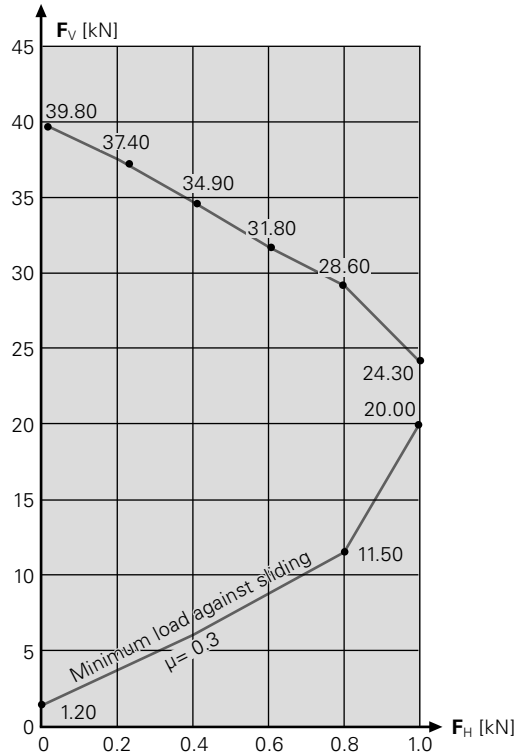

Cross Forkhead
TR 38 - 70 / 50

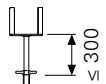

Adj. Base Plate
UJB 38 - 50 / 30

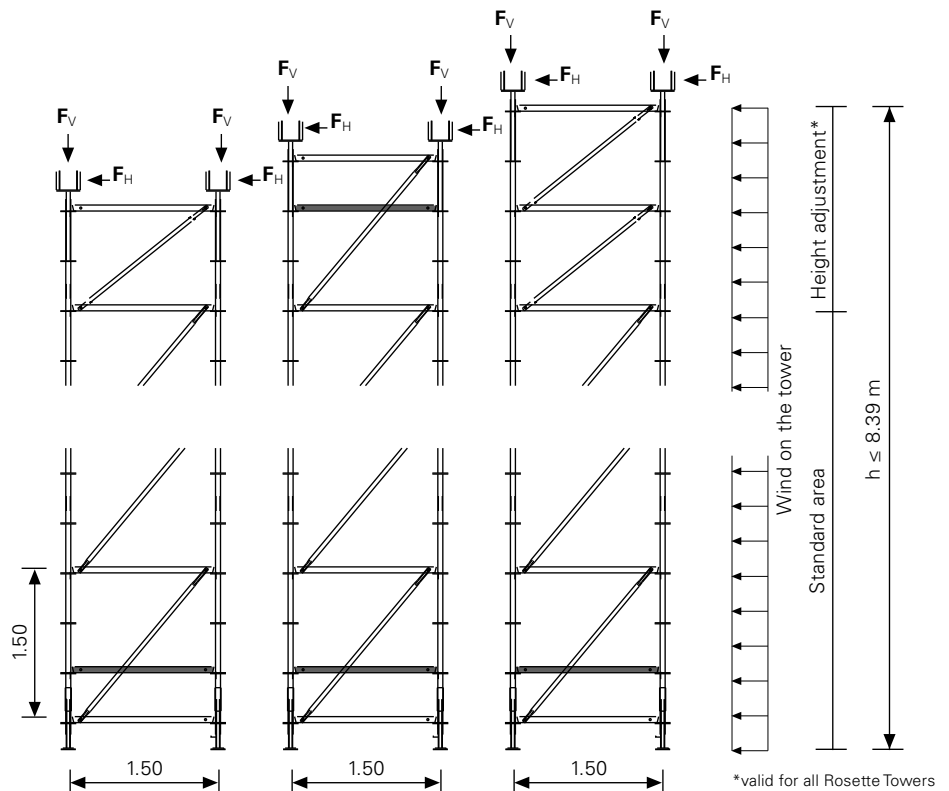
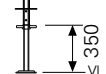

PERI UP Flex Shoring Tower

Instructions for Assembly and Use – Standard Configuration

PERI UP Flex Shoring Tower Plus

Permissible loads with TR 48 / TR 48



Load-bearing capacity per leg for shoring towers with Spindles TR 48 with a maximum supporting height of up to 16.26 m (restrained at the top).

Ground plan 150 x 150 cm

| Height of tower [m] | Spindle extensions [cm] | | Permissible loads [kN / leg] | |
|---------------------|-------------------------|-----------------|---------------------------------------|------------------------------------|
| | Base $L_{Sp,F}$ | Head $L_{Sp,K}$ | without wind (0.0 kN/m ²) | with wind (0.5 kN/m ²) |
| 15.15 | 35 | 30 | 52.37 | 50.05 |
| 10.65 | 35 | 30 | 53.99 | 51.99 |
| 7.65 | 35 | 30 | 56.43 | 55.03 |
| 15.58 | 20 | 88 | 30.45 | 24.40 |
| 11.08 | 20 | 88 | 37.05 | 32.73 |
| 8.08 | 20 | 88 | 44.47 | 42.04 |
| 15.58 | 88 | 20 | 43.14 | 31.02 |
| 11.08 | 88 | 20 | 48.07 | 41.53 |
| 8.08 | 88 | 20 | 50.36 | 48.76 |
| 15.78 | 88 | 40 | 40.32 | 27.85 |
| 11.28 | 88 | 40 | 42.68 | 36.31 |
| 8.28 | 88 | 40 | 42.73 | 38.27 |
| 16.26 | 88 | 88 | 25.50 | 16.98 |
| 11.76 | 88 | 88 | 25.96 | 19.72 |
| 8.76 | 88 | 88 | 26.27 | 21.71 |

Ground plan 150 x 250 cm

| Height of tower [m] | Spindle extensions [cm] | | Permissible loads [kN / leg] | |
|---------------------|-------------------------|-----------------|---------------------------------------|------------------------------------|
| | Base $L_{Sp,F}$ | Head $L_{Sp,K}$ | without wind (0.0 kN/m ²) | with wind (0.5 kN/m ²) |
| 15.15 | 35 | 30 | 52.37 | 48.02 |
| 10.65 | 35 | 30 | 53.99 | 50.97 |
| 7.65 | 35 | 30 | 56.43 | 54.13 |
| 15.58 | 20 | 88 | 30.45 | 22.24 |
| 11.08 | 20 | 88 | 37.05 | 31.07 |
| 8.08 | 20 | 88 | 44.47 | 41.16 |
| 15.58 | 88 | 20 | 43.14 | 26.08 |
| 11.08 | 88 | 20 | 48.07 | 38.39 |
| 8.08 | 88 | 20 | 50.36 | 47.48 |
| 15.78 | 88 | 40 | 40.32 | 23.07 |
| 11.28 | 88 | 40 | 42.68 | 33.25 |
| 8.28 | 88 | 40 | 42.73 | 36.73 |
| 16.26 | 88 | 88 | 25.50 | 13.64 |
| 11.76 | 88 | 88 | 25.96 | 17.55 |
| 8.76 | 88 | 88 | 26.27 | 19.97 |

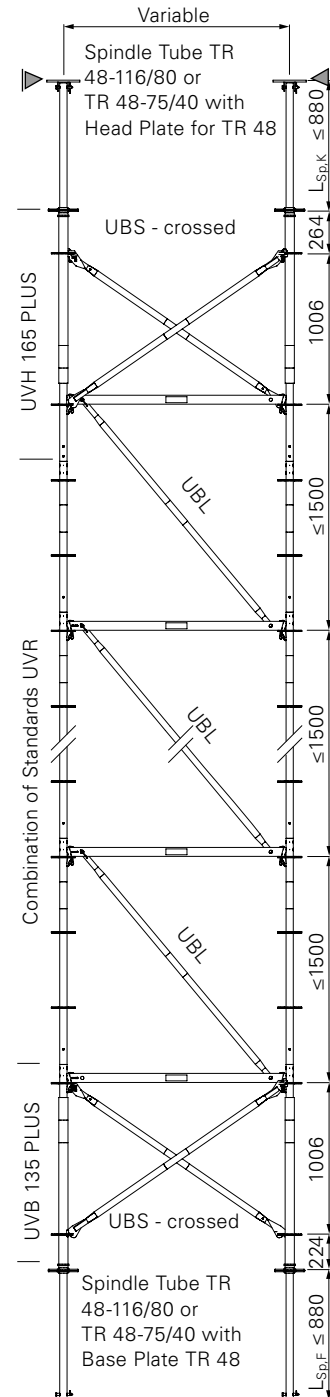

The values given also apply to lower system heights.
Length of the standards, ledgers and diagonals in accordance with geometrical requirements.

The standard joints must be at the same height of the ledgers.

PERI UP Flex Shoring Tower Plus

Permissible loads with TR 48 / TR 48



Load-bearing capacity per leg for shoring towers with Spindles TR 48 with a maximum supporting height of up to 16.26 m (restrained at the top).

Ground plan 100 x 150 cm

| Height of tower [m] | Spindle extensions [cm] | | Permissible loads [kN / leg] | |
|---------------------|-------------------------|-----------------|---------------------------------------|------------------------------------|
| | Base $L_{Sp,F}$ | Head $L_{Sp,K}$ | without wind (0.0 kN/m ²) | with wind (0.5 kN/m ²) |
| 15.15 | 35 | 30 | 50.72 | 45.55 |
| 10.65 | 35 | 30 | 51.20 | 47.75 |
| 7.65 | 35 | 30 | 55.04 | 52.88 |
| 15.58 | 20 | 88 | 26.23 | 20.29 |
| 11.08 | 20 | 88 | 30.31 | 25.98 |
| 8.08 | 20 | 88 | 36.24 | 33.04 |
| 15.58 | 88 | 20 | 38.49 | 25.28 |
| 11.08 | 88 | 20 | 42.74 | 34.77 |
| 8.08 | 88 | 20 | 47.14 | 42.56 |
| 15.78 | 88 | 40 | 37.40 | 24.00 |
| 11.28 | 88 | 40 | 40.13 | 31.77 |
| 8.28 | 88 | 40 | 42.29 | 37.57 |
| 16.26 | 88 | 88 | 24.30 | 16.50 |
| 11.76 | 88 | 88 | 25.45 | 19.19 |
| 8.76 | 88 | 88 | 25.94 | 21.30 |

Ground plan 100 x 250 cm

| Height of tower [m] | Spindle extensions [cm] | | Permissible loads [kN / leg] | |
|---------------------|-------------------------|-----------------|---------------------------------------|------------------------------------|
| | Base $L_{Sp,F}$ | Head $L_{Sp,K}$ | without wind (0.0 kN/m ²) | with wind (0.5 kN/m ²) |
| 15.15 | 35 | 30 | 50.72 | 43.39 |
| 10.65 | 35 | 30 | 51.20 | 46.50 |
| 7.65 | 35 | 30 | 55.04 | 51.80 |
| 15.58 | 20 | 88 | 26.23 | 18.00 |
| 11.08 | 20 | 88 | 30.31 | 24.27 |
| 8.08 | 20 | 88 | 36.24 | 31.73 |
| 15.58 | 88 | 20 | 38.49 | 20.61 |
| 11.08 | 88 | 20 | 42.74 | 31.56 |
| 8.08 | 88 | 20 | 47.14 | 40.37 |
| 15.78 | 88 | 40 | 37.40 | 19.43 |
| 11.28 | 88 | 40 | 40.13 | 28.43 |
| 8.28 | 88 | 40 | 42.29 | 35.56 |
| 16.26 | 88 | 88 | 24.30 | 13.00 |
| 11.76 | 88 | 88 | 25.45 | 17.02 |
| 8.76 | 88 | 88 | 25.94 | 19.62 |

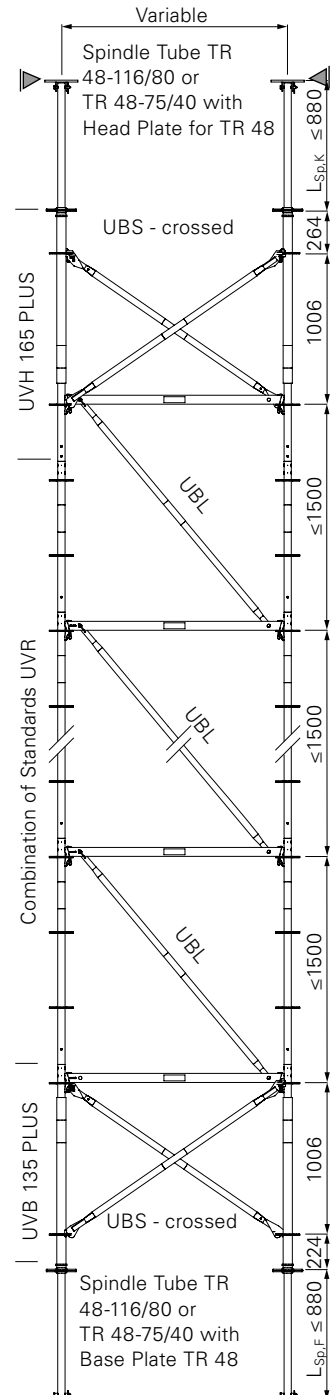

The values given also apply to lower system heights.

Length of the standards, ledgers and diagonals in accordance with geometrical requirements.

The standard joints must be at the same height of the ledgers.

PERI UP Flex Shoring Tower

Instructions for Assembly and Use – Standard Configuration

PERI UP Flex Shoring Tower Plus

Permissible loads with TR 48 / TR 48



Load-bearing capacity per leg for shoring towers with Spindle TR 48 at Base or Head with a maximum supporting height of up to 15.58 m (restrained at the top).

Ground plan 150 x 150 cm

| Height of tower [m] | Spindle extensions [cm] | | Permissible loads [kN / leg] | |
|---------------------|-------------------------|------------------------|---------------------------------------|------------------------------------|
| | Base L _{Sp,F} | Head L _{Sp,K} | without wind (0.0 kN/m ²) | with wind (0.5 kN/m ²) |
| 15,58 | 88 | 20 | 42,47 | 28,76 |
| 11,08 | 88 | 20 | 46,02 | 39,19 |
| 8,08 | 88 | 20 | 46,35 | 41,95 |

| Height of tower [m] | Spindle extensions [cm] | | Permissible loads [kN / leg] | |
|---------------------|-------------------------|------------------------|---------------------------------------|------------------------------------|
| | Base L _{Sp,F} | Head L _{Sp,K} | without wind (0.0 kN/m ²) | with wind (0.5 kN/m ²) |
| 15,58 | 88 | 20 | 42,47 | 26,60 |
| 11,08 | 88 | 20 | 46,02 | 37,98 |
| 8,08 | 88 | 20 | 46,35 | 41,46 |

Ground plan 150 x 250 cm

| Height of tower [m] | Spindle extensions [cm] | | Permissible loads [kN / leg] | |
|---------------------|-------------------------|------------------------|---------------------------------------|------------------------------------|
| | Base L _{Sp,F} | Head L _{Sp,K} | without wind (0.0 kN/m ²) | with wind (0.5 kN/m ²) |
| 15,58 | 88 | 20 | 42,47 | 24,43 |
| 11,08 | 88 | 20 | 46,02 | 36,47 |
| 8,08 | 88 | 20 | 46,35 | 40,51 |

Ground plan 100 x 150 cm

| Height of tower [m] | Spindle extensions [cm] | | Permissible loads [kN / leg] | |
|---------------------|-------------------------|------------------------|---------------------------------------|------------------------------------|
| | Base L _{Sp,F} | Head L _{Sp,K} | without wind (0.0 kN/m ²) | with wind (0.5 kN/m ²) |
| 15,58 | 88 | 20 | 37,60 | 23,72 |
| 11,08 | 88 | 20 | 41,27 | 32,83 |
| 8,08 | 88 | 20 | 44,90 | 39,40 |

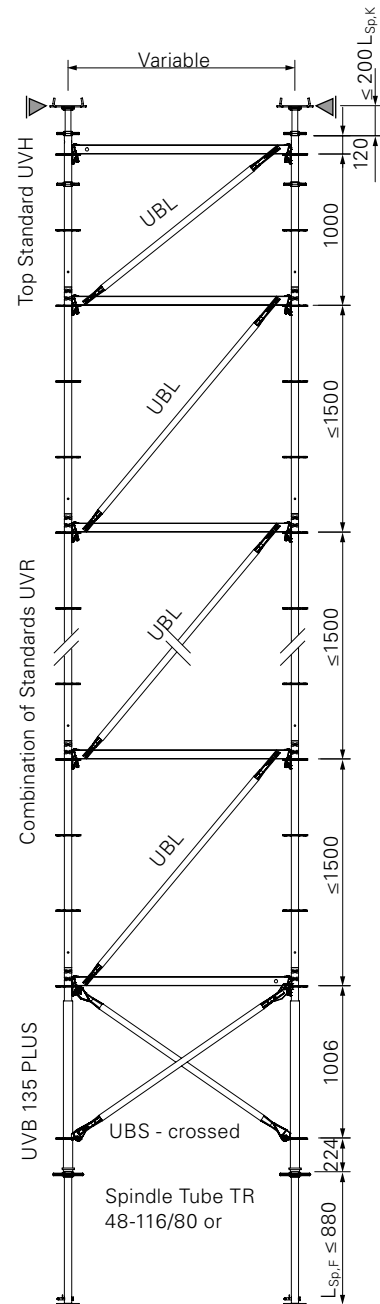

The values given also apply to lower system heights.

Length of the standards, ledgers and diagonals in accordance with geometrical requirements.

The standard joints must be at the same height of the ledgers.

| Item no. | Weight kg |
|----------|-----------|
| 100244 | 1.200 |

Base Plate UJP
Without height adjustment.

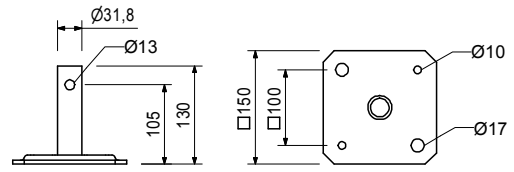
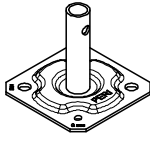

| | |
|--------|-------|
| 100411 | 3.390 |
|--------|-------|

Adj. Base Plate UJB 38-50/30

Note
With captive red Quick Jack Nut.

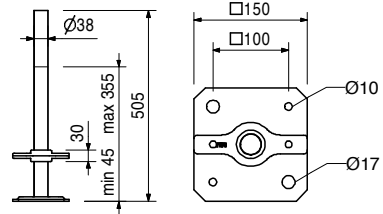

| | |
|--------|-------|
| 100242 | 4.570 |
|--------|-------|

Adj. Base Plate UJB 38-80/55

Note
With captive yellow Quick Jack Nut.

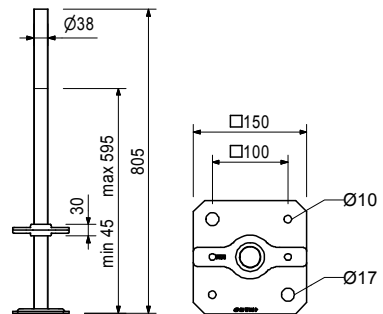
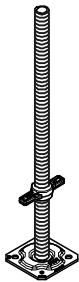

| | |
|--------|-------|
| 019780 | 5.250 |
|--------|-------|

Base Spindle TR 38-70/50
For heavily loaded shoring.

Note
With captive silver Quick Jack Nut.

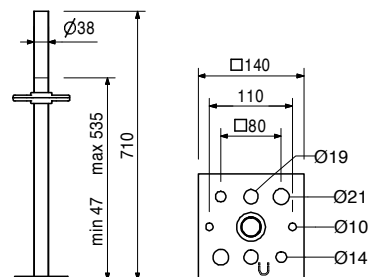
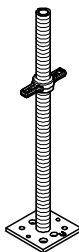

PERI UP Flex Shoring Tower



| Item no. | Weight kg |
|----------|-----------|
| 019950 | 7.770 |

Cross Forkhead TR 38-70/50

Tilt-resistant head spindle for holding one or two GT 24 or VT 20 Girders.

Note

With captive Quick Jack Nut.

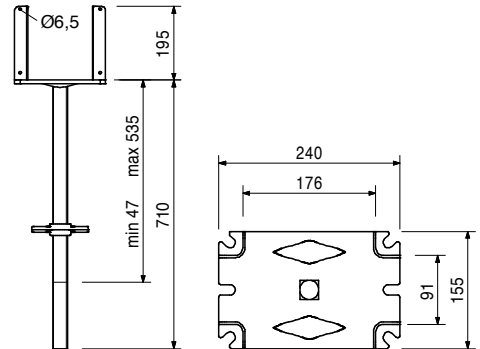
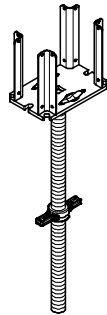

Accessories

| | |
|--------|-------|
| 028590 | 0.568 |
|--------|-------|

Tension Strap 16-25, galv.

| | |
|--------|-------|
| 319790 | 6.460 |
|--------|-------|

Head Spindle TR 38-70/50, galv.

Maximum inclination of the head plate on all sides 4.4°.

Note

With captive Quick Jack Nut.

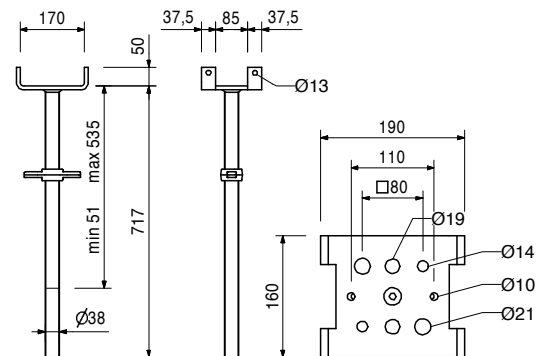
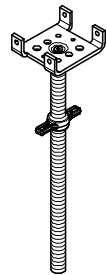

| | |
|--------|-------|
| 116081 | 7.040 |
|--------|-------|

Head Spindle-2 TR 38-70/50

Maximum inclination of the head plate on all sides 4.4°.

Note

With locking device and captive Quick Jack Nut.

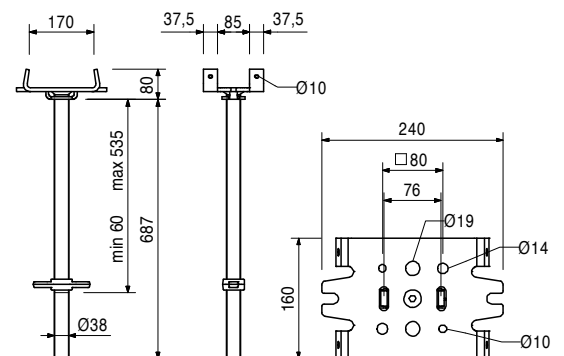
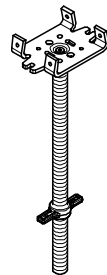

Accessories

| | |
|--------|-------|
| 028590 | 0.568 |
| 018300 | 0.564 |

Tension Strap 16-25, galv.

Cross Strap, galv.

| Item no. | Weight kg |
|----------|-----------|
| 028590 | 0.568 |

Tension Strap 16-25, galv.

For mounting 2 GT 24 or VT 20 Girders on the Cross Forkhead and Head Spindle TR 38 and on the Crosshead 20/24 or 20/24S.

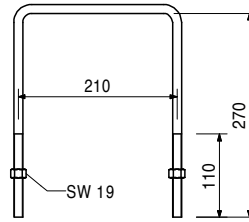
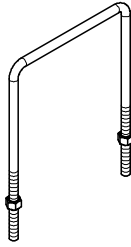

| | |
|--------|-------|
| 018300 | 0.564 |
|--------|-------|

Cross Strap, galv.

For fixing Steel Walers SRZ and SRU on the Head Spindle TR 38.

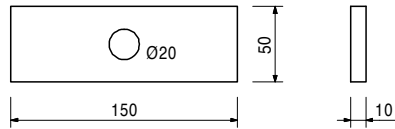
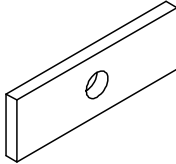

| | |
|--------|-------|
| 018350 | 0.310 |
|--------|-------|

Accessories

Bolt ISO 4016 M16 x 160-4.6 MU, galv.

| | |
|--------|-------|
| 109630 | 4.240 |
|--------|-------|

Spindle Head SRU

For connecting the Steel Walers SRU and SRZ to the shoring.

Note

With captive Quick Jack Nut.

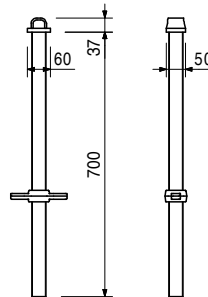
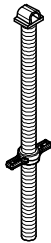

| | |
|--------|-------|
| 104031 | 0.462 |
| 018060 | 0.030 |

Accessories

Fitting Pin Ø 21 x 120

Cotter Pin 4/1, galv.

| Item no. | Weight kg |
|----------|-----------|
| 111072 | 6.300 |

Section Spindle UJK 38-110/41

For erection of shoring with tower units.

Note

With captive Quick Jack Nut.

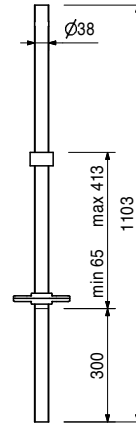
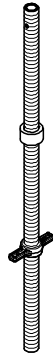

| | |
|--------|-------|
| 100863 | 1.020 |
|--------|-------|

Spindle Locking UJS

Secures the Adjustable Base Plates and Section Spindles Ø 38 mm in the leg while moving.

Technical Data

Permissible load 1.5 kN.

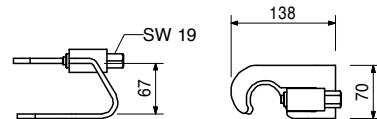

| | |
|--------|-------|
| 109563 | 1.460 |
|--------|-------|

Head Spindle Locking UJH

Connects Head Spindle and Section Spindle with Ledger UH when moving.

Complete with

1 pc. 018060 Cotter Pin 4/1, galv.

Technical Data

Permissible load 2.1 kN.

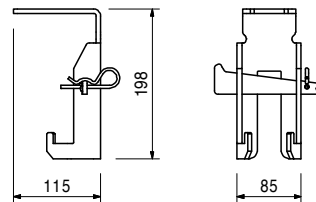
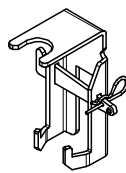

| | |
|--------|-------|
| 100014 | 2.470 |
|--------|-------|

Base Standard UVB 24

For assembly directly on the base spindle.

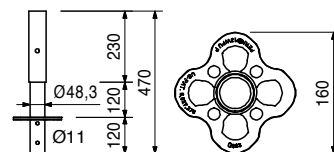
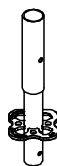

| Item no. | Weight kg |
|----------|-----------|
| 117194 | 3.980 |

Base Standard UVB 49

For assembly directly on the base spindle.
Reduces necessary spindle extension lengths
through distance between rosettes of 25 cm.

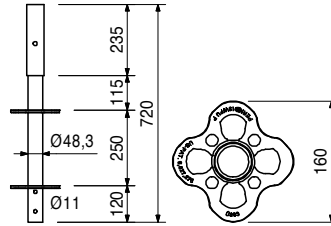

| | | Standards UVR | L |
|--------|--------|------------------|------|
| 102859 | 3.080 | Standard UVR 50 | 500 |
| 101306 | 5.380 | Standard UVR 100 | 1000 |
| 102860 | 7.690 | Standard UVR 150 | 1500 |
| 100009 | 10.000 | Standard UVR 200 | 2000 |
| 100012 | 14.700 | Standard UVR 300 | 3000 |
| 100013 | 19.200 | Standard UVR 400 | 4000 |

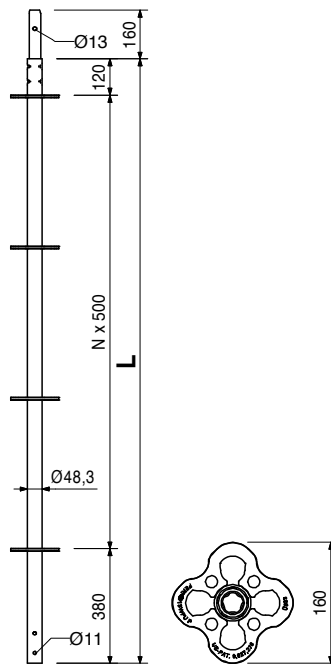
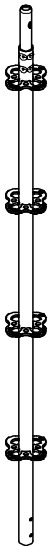

PERI UP Flex Shoring Tower



| Item no. | Weight kg |
|----------|-----------|
| 100000 | 4.610 |
| 100003 | 6.920 |
| 100005 | 9.240 |
| 100007 | 11.500 |

Top Standards UVH
Top Standard UVH 100
Top Standard UVH 150
Top Standard UVH 200
Top Standard UVH 250

| L |
|------|
| 1000 |
| 1500 |
| 2000 |
| 2500 |

Without spigot for supporting head spindles.

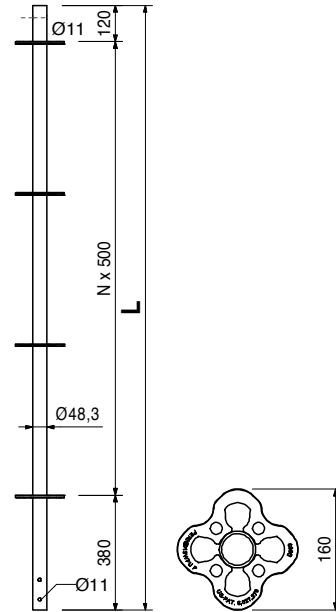

| Item no. | Weight kg | Product Name |
|----------|-----------|---------------------------|
| 114613 | 1.420 | Ledgers UH Plus |
| 114595 | 2.070 | Ledger UH 25 Plus |
| 114629 | 2.730 | Ledger UH 50 Plus |
| 114632 | 4.460 | Ledger UH 75 Plus |
| 114638 | 5.430 | Ledger UH 100 Plus |
| 114641 | 4.710 | Ledger UH 125 Plus |
| 117032 | 5.380 | Ledger UH 150 Plus |
| 114645 | 6.040 | Ledger UH 175 Plus |
| 116356 | 6.700 | Ledger UH 200 Plus |
| 114648 | 7.360 | Ledger UH 225 Plus |
| 114651 | 8.680 | Ledger UH 250 Plus |
| | | Ledger UH 300 Plus |

| L | X | Sticker |
|------|------|---------|
| 204 | 250 | |
| 454 | 500 | |
| 704 | 750 | White |
| 954 | 1000 | White |
| 1204 | 1250 | |
| 1454 | 1500 | |
| 1704 | 1750 | |
| 1954 | 2000 | |
| 2204 | 2250 | |
| 2454 | 2500 | |
| 2954 | 3000 | |

Note

Longitudinally-stamped and with coloured label for easier identification.

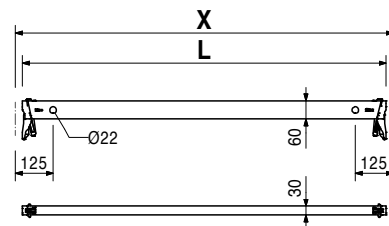
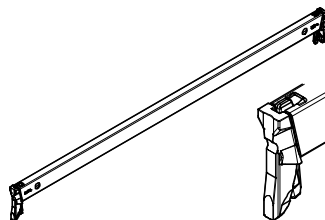

| Item no. | Weight kg | | L | X | Sticker |
|----------|-----------|----------------------|------|------|---------|
| | | Ledgers UH | | | |
| 404780 | 1.390 | Ledger UH 25 | 204 | 250 | |
| 404779 | 2.040 | Ledger UH 50 | 454 | 500 | |
| 400017 | 2.710 | Ledger UH 75 | 704 | 750 | White |
| 401159 | 3.370 | Ledger UH 100 | 954 | 1000 | White |
| 410347 | 4.020 | Ledger UH 125 | 1204 | 1250 | |
| 400021 | 4.690 | Ledger UH 150 | 1454 | 1500 | |
| 400023 | 6.020 | Ledger UH 200 | 1954 | 2000 | White |
| 400025 | 7.340 | Ledger UH 250 | 2454 | 2500 | Red |
| 400027 | 8.670 | Ledger UH 300 | 2954 | 3000 | Black |

Note

Longitudinally-stamped and with coloured label for easier identification.

Ledgers UH can be replaced by Ledgers UH Plus.

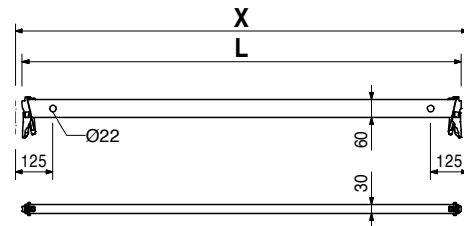
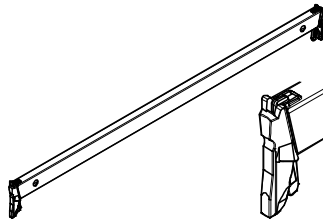

| | | |
|--------|-------|---|
| 019940 | 2.270 | Diagonal Strut ST 100, galv. Diagonals for Stacking Tower ST 100. Number required depends on the static system. |
|--------|-------|---|

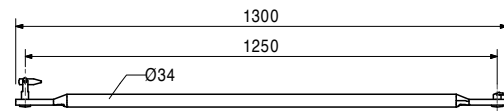
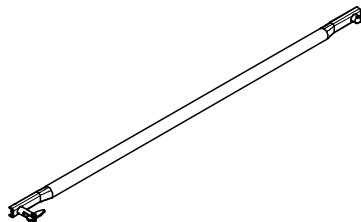

| Item no. | Weight kg | | L | X | Y | Sticker |
|----------|-----------|---------------------------------|------|------|------|---------|
| | | Ledger Braces UBL | | | | |
| 115156 | 2.660 | Ledger Brace UBL 100/50 | 901 | 1000 | 500 | |
| 115513 | 4.640 | Ledger Brace UBL 100/150 | 1677 | 1000 | 1500 | |
| 115157 | 5.810 | Ledger Brace UBL 100/200 | 2136 | 1000 | 2000 | |
| 107867 | 3.790 | Ledger Brace UBL 150/50 | 1347 | 1500 | 500 | |
| 100055 | 4.440 | Ledger Brace UBL 150/100 | 1601 | 1500 | 1000 | |
| 102846 | 5.340 | Ledger Brace UBL 150/150 | 1953 | 1500 | 1500 | |
| 100057 | 6.380 | Ledger Brace UBL 150/200 | 2358 | 1500 | 2000 | |
| 109034 | 6.740 | Ledger Brace UBL 175/200 | 2500 | 1750 | 2000 | |
| 104391 | 5.000 | Ledger Brace UBL 200/50 | 1820 | 2000 | 500 | |
| 100059 | 5.500 | Ledger Brace UBL 200/100 | 2016 | 2000 | 1000 | |
| 102862 | 6.240 | Ledger Brace UBL 200/150 | 2305 | 2000 | 1500 | |
| 100061 | 7.160 | Ledger Brace UBL 200/200 | 2658 | 2000 | 2000 | White |
| 130282 | 5.620 | Ledger Brace UBL 225/50 | 2062 | 2250 | 500 | |
| 130283 | 6.070 | Ledger Brace UBL 225/100 | 2236 | 2250 | 1000 | |
| 117689 | 7.580 | Ledger Brace UBL 225/200 | 2829 | 2250 | 2000 | |
| 100063 | 6.640 | Ledger Brace UBL 250/100 | 2462 | 2500 | 1000 | |
| 102861 | 7.260 | Ledger Brace UBL 250/150 | 2705 | 2500 | 1500 | |
| 100065 | 8.050 | Ledger Brace UBL 250/200 | 3010 | 2500 | 2000 | Red |
| 104762 | 7.490 | Ledger Brace UBL 300/50 | 2795 | 3000 | 500 | |
| 100067 | 7.830 | Ledger Brace UBL 300/100 | 2926 | 3000 | 1000 | |
| 104766 | 8.360 | Ledger Brace UBL 300/150 | 3133 | 3000 | 1500 | |
| 100069 | 9.050 | Ledger Brace UBL 300/200 | 3400 | 3000 | 2000 | Black |

Mounted in the holes of the ledger.

Note

Longitudinally-stamped and with coloured label for easier identification.

UBL 150/250 identical to UBL 300/50,

UBL 225/150 identical to UBL 175/200,

UBL 250/50 identical to UBL 200/150.

UBL 75/200 identical to UBL 225/50.

UBL 100/100 identical to Diagonal Strut ST 100 (Item no. 019940).

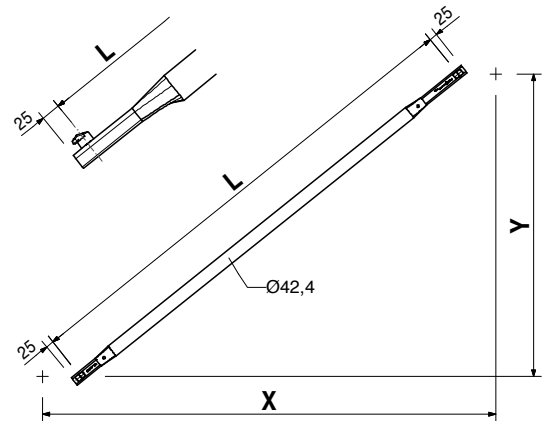
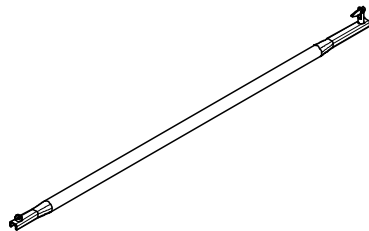

PERI UP Flex Shoring Tower



| Item no. | Weight kg | | L | X | Y |
|----------|-----------|-------------------------------------|------|------|------|
| | | Horizontal Braces UBH | | | |
| 400042 | 7.350 | Horizontal Brace UBH 150/150 | 2042 | 1500 | 1500 |
| 407815 | 8.700 | Horizontal Brace UBH 200/150 | 2422 | 2000 | 1500 |
| 400047 | 9.870 | Horizontal Brace UBH 200/200 | 2749 | 2000 | 2000 |
| 406931 | 10.200 | Horizontal Brace UBH 250/150 | 2838 | 2500 | 1500 |
| 404356 | 11.300 | Horizontal Brace UBH 250/200 | 3123 | 2500 | 2000 |
| 400049 | 12.400 | Horizontal Brace UBH 250/250 | 3456 | 2500 | 2500 |
| 400051 | 11.800 | Horizontal Brace UBH 300/150 | 3279 | 3000 | 1500 |
| 423483 | 12.700 | Horizontal Brace UBH 300/200 | 3528 | 3000 | 2000 |
| 402617 | 13.800 | Horizontal Brace UBH 300/250 | 3826 | 3000 | 2500 |
| 400053 | 15.000 | Horizontal Brace UBH 300/300 | 4164 | 3000 | 3000 |

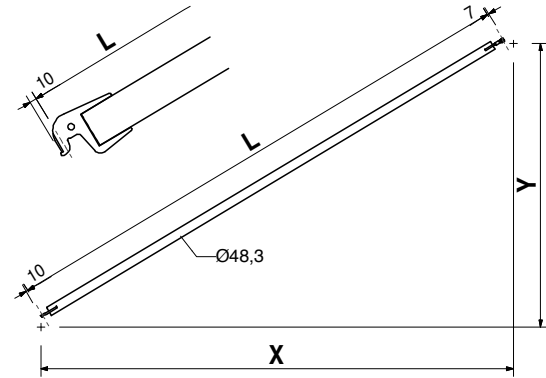
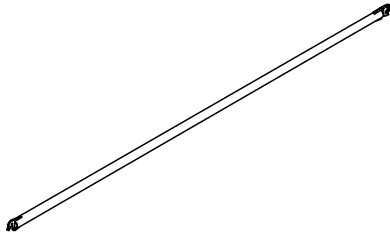

| | | H-Braces UBH Flex | L | X | Y |
|--------|--------|---------------------------------|------|------|------|
| 114818 | 4.580 | H-Brace UBH Flex 100/100 | 1335 | 1000 | 1000 |
| 114821 | 5.720 | H-Brace UBH Flex 150/100 | 1725 | 1500 | 1000 |
| 114912 | 6.650 | H-Brace UBH Flex 150/150 | 2042 | 1500 | 1500 |
| 114820 | 7.000 | H-Brace UBH Flex 200/100 | 2161 | 2000 | 1000 |
| 114916 | 8.730 | H-Brace UBH Flex 200/200 | 2749 | 2000 | 2000 |
| 114819 | 8.350 | H-Brace UBH Flex 250/100 | 2620 | 2500 | 1000 |
| 114996 | 8.640 | H-Brace UBH Flex 250/125 | 2720 | 2500 | 1250 |
| 124101 | 8.990 | H-Brace UBH Flex 250/150 | 2838 | 2500 | 1500 |
| 114920 | 9.830 | H-Brace UBH Flex 250/200 | 3123 | 2500 | 2000 |
| 114928 | 10.800 | H-Brace UBH Flex 250/250 | 3456 | 2500 | 2500 |
| 114892 | 9.730 | H-Brace UBH Flex 300/100 | 3092 | 3000 | 1000 |
| 114924 | 11.000 | H-Brace UBH Flex 300/200 | 3528 | 3000 | 2000 |
| 114932 | 11.900 | H-Brace UBH Flex 300/250 | 3826 | 3000 | 2500 |
| 114936 | 12.900 | H-Brace UBH Flex 300/300 | 4163 | 3000 | 3000 |

For horizontal bracing of towers. Also useable underneath deckings UDI and UDG.

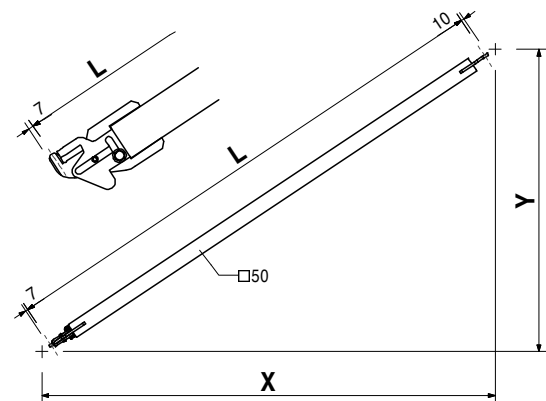
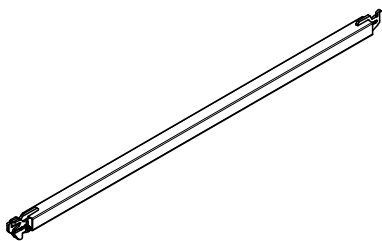

PERI UP Flex Shoring Tower



Item no. Weight kg

| Item no. | Weight kg | Shoring Braces UBS |
|----------|-----------|---------------------------|
| 128936 | 4.250 | Shoring Brace UBS 100/100 |
| 129354 | 5.300 | Shoring Brace UBS 100/150 |
| 107801 | 5.260 | Shoring Brace UBS 150/100 |
| 107810 | 6.050 | Shoring Brace UBS 150/150 |
| 115504 | 6.360 | Shoring Brace UBS 200/100 |
| 115291 | 7.050 | Shoring Brace UBS 200/150 |
| 123592 | 7.630 | Shoring Brace UBS 250/100 |
| 123588 | 8.090 | Shoring Brace UBS 250/150 |
| 123584 | 8.820 | Shoring Brace UBS 300/100 |
| 123580 | 9.360 | Shoring Brace UBS 300/150 |

Standard diagonal for shoring frames.

| L | X | Y |
|------|------|------|
| 1413 | 1000 | 1000 |
| 1771 | 1000 | 1500 |
| 1792 | 1500 | 1000 |
| 2122 | 1500 | 1500 |
| 2219 | 2000 | 1000 |
| 2492 | 2000 | 1500 |
| 2672 | 2500 | 1000 |
| 2902 | 2500 | 1500 |
| 3139 | 3000 | 1000 |
| 3337 | 3000 | 1500 |

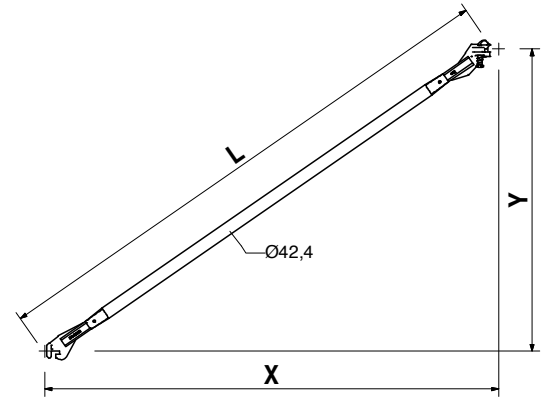
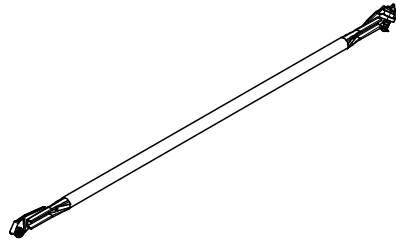

| Item no. | Weight kg | Industrial Decks Steel UDI 25 |
|----------|-----------|-------------------------------|
| 404029 | 4.090 | Industrial Deck UDI 25 x 50 |
| 405925 | 5.520 | Industrial Deck UDI 25 x 75 |
| 406092 | 6.950 | Industrial Deck UDI 25 x 100 |
| 406880 | 8.380 | Industrial Deck UDI 25 x 125 |
| 407002 | 9.790 | Industrial Deck UDI 25 x 150 |
| 408380 | 12.700 | Industrial Deck UDI 25 x 200 |
| 408540 | 15.500 | Industrial Deck UDI 25 x 250 |
| 408689 | 18.400 | Industrial Deck UDI 25 x 300 |

Mounted on Ledgers UH.

| X | perm. p [kN/m ²] | max. p [kN/m ²] |
|------|------------------------------|-----------------------------|
| 500 | 6.0 | 40.0 |
| 750 | 6.0 | 40.0 |
| 1000 | 6.0 | 40.0 |
| 1250 | 6.0 | 28.4 |
| 1500 | 6.0 | 19.6 |
| 2000 | 6.0 | 10.9 |
| 2500 | 4.5 | 6.9 |
| 3000 | 3.0 | 4.7 |

Note

perm. p according to DIN EN 12811-1.
max. p = maximum possible load without deflection limitation.

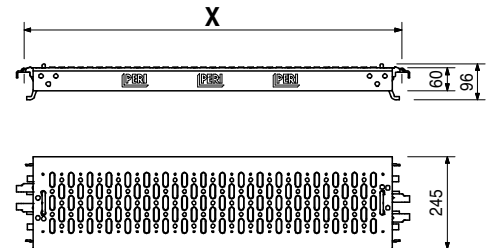
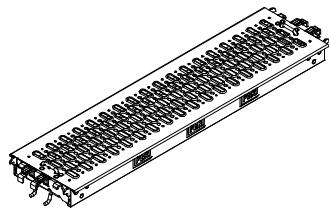

PERI UP Flex Shoring Tower



Item no. Weight kg

| Item no. | Weight kg | Steel Decks UDG |
|----------|-----------|-------------------------|
| 124124 | 3.880 | Steel Deck UDG 25 x 50 |
| 124121 | 5.260 | Steel Deck UDG 25 x 75 |
| 124118 | 6.630 | Steel Deck UDG 25 x 100 |
| 124115 | 8.010 | Steel Deck UDG 25 x 125 |
| 124112 | 9.410 | Steel Deck UDG 25 x 150 |
| 124109 | 12.200 | Steel Deck UDG 25 x 200 |
| 123771 | 14.900 | Steel Deck UDG 25 x 250 |
| 124915 | 17.700 | Steel Deck UDG 25 x 300 |

Mounted on Ledgers UH.

| X | perm. p [kN/m ²] | max. p [kN/m ²] |
|------|------------------------------|-----------------------------|
| 500 | 6.0 | 40.0 |
| 750 | 6.0 | 40.0 |
| 1000 | 6.0 | 40.0 |
| 1250 | 6.0 | 28.4 |
| 1500 | 6.0 | 19.6 |
| 2000 | 6.0 | 10.9 |
| 2500 | 4.5 | 6.9 |
| 3000 | 3.0 | 4.7 |

Note

Perm. p according to DIN EN 12811-1.
max. p = maximum possible load without deflection limitation.

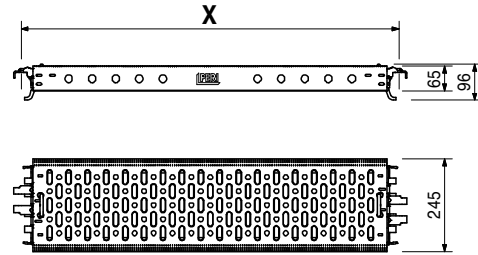
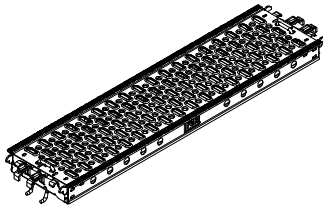

109755 15.700

Hatch UAF 75 x 100

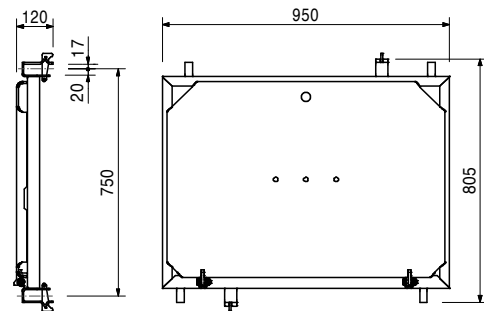
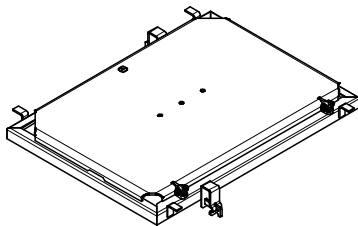

Accessories

109879 3.820

Ladder UAF 200, Alu

109879 3.820

Ladder UAF 200, Alu

For mounting to Hatch UAF.

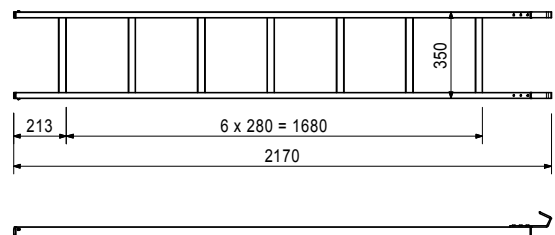
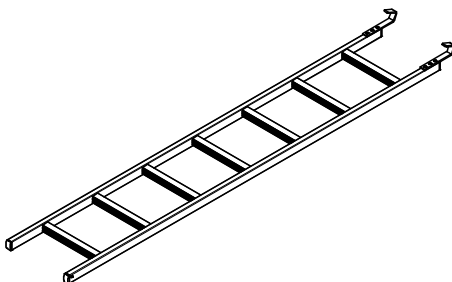

| Item no. | Weight kg |
|----------|-----------|
| 126393 | 15.600 |
| 126392 | 19.600 |
| 126314 | 23.500 |

Access Decks UAL-3
Access Deck UAL-3, 75 x 150/3
Access Deck UAL-3, 75 x 200/3
Access Deck UAL-3, 75 x 250/3

L
 1500
 2000
 2500

Technical Data
 Load Class 3, 2.0 kN/m².

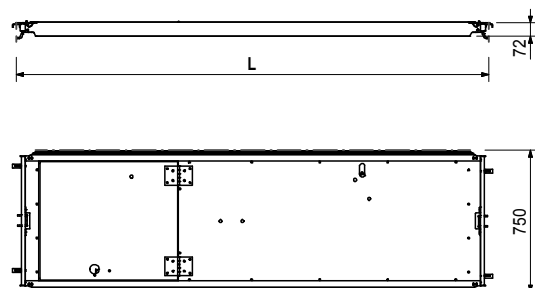
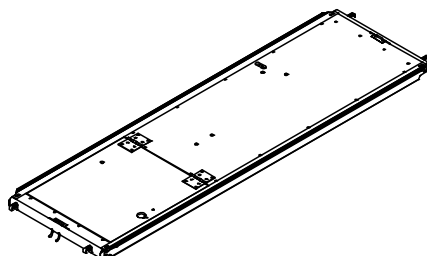

Accessories

| | |
|--------|-------|
| 126318 | 3.750 |
|--------|-------|

Ladder Flex UEL with hook

| | |
|--------|-------|
| 126318 | 3.750 |
|--------|-------|

Ladder Flex UEL with hook

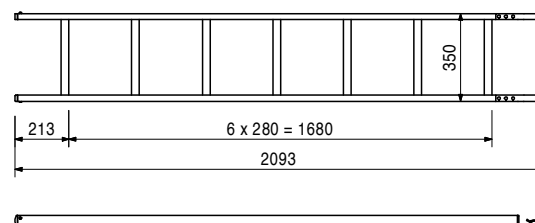
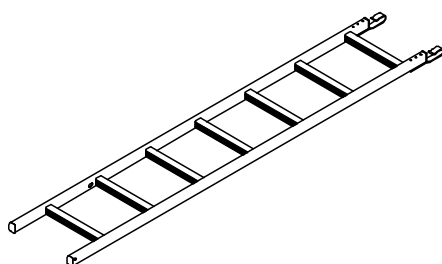

| | |
|--------|-------|
| 117196 | 9.930 |
|--------|-------|

Base Standard UVB 135 Plus

Use of Spindle Tube TR 48 in the base area through the transition of standard \varnothing 48 mm on a standard with \varnothing 60 mm.

Note

For horizontal bracing by Shoring Braces UBS (crossed)

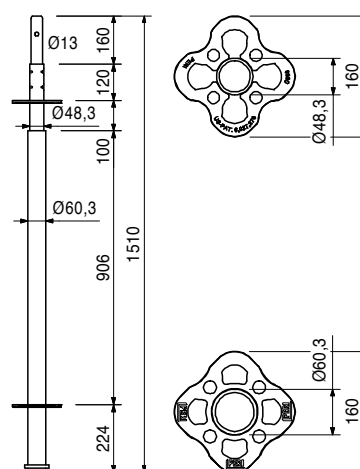
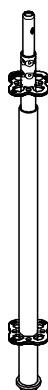

| Item no. | Weight kg |
|----------|-----------|
| 117197 | 10.400 |

Top Standard UVH 165 Plus

Use of Spindle Tube TR 48 and Cross Forkhead TR 48 in the top area through the transition of standards $\varnothing 48$ mm on a standard with $\varnothing 60$ mm.

Note

For horizontal bracing by Shoring Braces UBS (crossed)

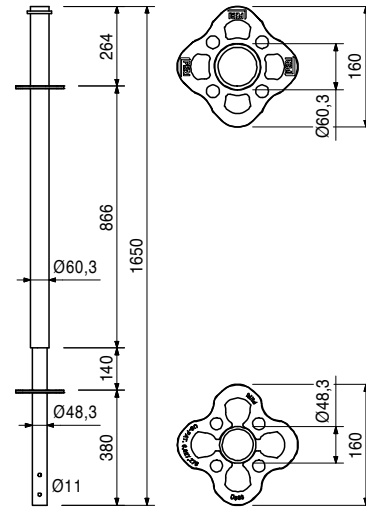
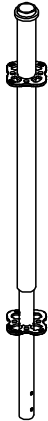

| | |
|--------|-------|
| 018630 | 9.500 |
|--------|-------|

Cross Head Spindle TR 48-75/47, galv.

Head spindle for PD 8 Slab Table and Flex Plus Shoring.

Complete with

1 pc. 018270 Quick Jack Nut TR 48, galv.

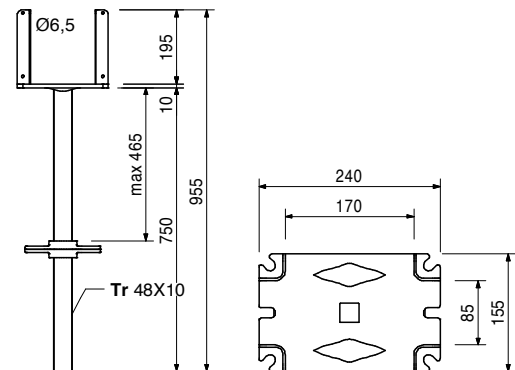
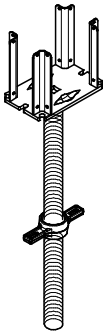

| | |
|--------|-------|
| 028590 | 0.568 |
|--------|-------|

Accessories

Tension Strap 16-25, galv.

Item no. Weight kg

| | |
|--------|-------|
| 018120 | 4.400 |
| 018030 | 6.820 |

Spindle Tubes TR 48, galv.

Spindle Tube TR 48-75/40, galv.

Spindle Tube TR 48-116/80, galv.

For use as head and base spindle for the PD 8 Systems and Flex Plus Shoring.

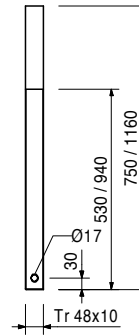

Accessories

| | |
|--------|-------|
| 127604 | 1.270 |
|--------|-------|

Quick Jack Nut TR 48-2, galv.

| | |
|--------|-------|
| 318270 | 0.800 |
|--------|-------|

Quick Jack Nut TR 48, galv.

For spindles Ø 48 mm.

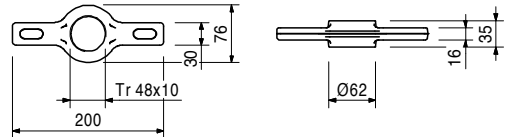
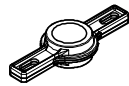

| | |
|--------|-------|
| 127604 | 1.270 |
|--------|-------|

Quick Jack Nut TR 48-2, galv.

For spindles Ø 48 mm; with additional groove.

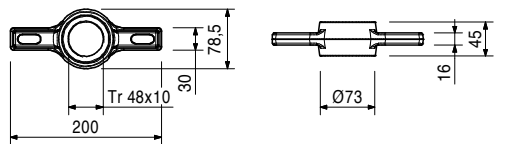
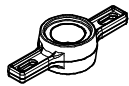

| | |
|--------|-------|
| 117743 | 0.798 |
|--------|-------|

Handle Lock UJS Plus

Secures Head- and Base Spindles Ø 48 mm in the Standard Plus during moving.

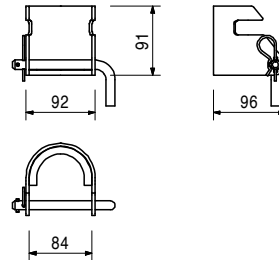

| Item no. | Weight kg |
|----------|-----------|
| 018070 | 1.770 |

Base Plate for Spindle Tube TR 48

Base plate for Spindle Tubes and Foot Tube FR 80.

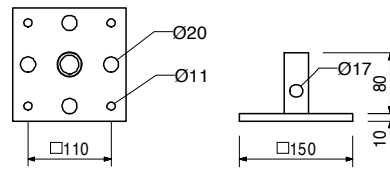
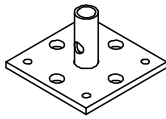

Accessories

| | |
|--------|-------|
| 018050 | 0.171 |
| 018060 | 0.030 |

Pin Ø 16 x 65/86, galv.
Cotter Pin 4/1, galv.

| | |
|--------|-------|
| 018040 | 3.770 |
|--------|-------|

Head Plate for Spindle Tube TR 48

Note

Can be pivoted by 2.1 % in combination with Cap Piece.

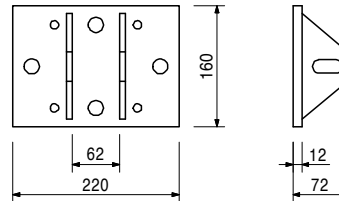

Accessories

| | |
|--------|-------|
| 018050 | 0.171 |
| 018060 | 0.030 |
| 019660 | 0.288 |

Pin Ø 16 x 65/86, galv.
Cotter Pin 4/1, galv.
Cap Piece, galv.

| | |
|--------|-------|
| 019660 | 0.288 |
|--------|-------|

Cap Piece, galv.

For centric load application. Allows 2.1% inclination of the head plate.

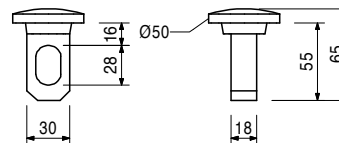
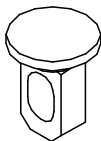

| | |
|--------|-------|
| 107160 | 3.960 |
|--------|-------|

Connector MP-SRU

As compensation element between the Prop Head MP/SRU and inclined positioned Steel Waler SRU.

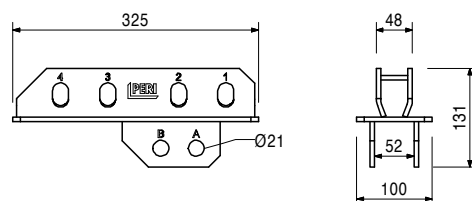
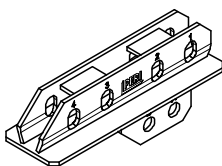

Accessories

| | |
|--------|-------|
| 104031 | 0.462 |
| 018060 | 0.030 |

Fitting Pin Ø 21 x 120
Cotter Pin 4/1, galv.

| Item no. | Weight kg |
|----------|-----------|
| 104031 | 0.462 |

Fitting Pin Ø 21 x 120
For different connections.

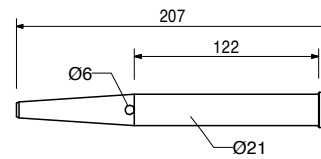
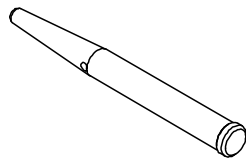

| | |
|--------|-------|
| 018060 | 0.030 |
|--------|-------|

Accessories
Cotter Pin 4/1, galv.

| | |
|--------|-------|
| 018050 | 0.171 |
|--------|-------|

Pin Ø 16 x 65/86, galv.
For different connections.

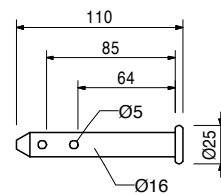
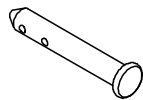

| | |
|--------|-------|
| 018060 | 0.030 |
|--------|-------|

Accessories
Cotter Pin 4/1, galv.

| | |
|--------|-------|
| 018060 | 0.030 |
|--------|-------|

Cotter Pin 4/1, galv.



| | |
|--------|-------|
| 100301 | 1.020 |
|--------|-------|

Spigot ULT 32
Lose pin for connecting Scaffold Tubes
Ø 48.3 x 3.2 mm, e.g. top standards, lattice girders.

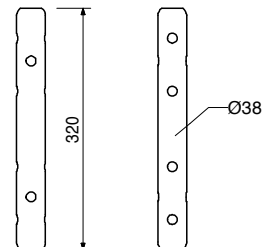

| | |
|--------|-------|
| 111053 | 0.059 |
| 100719 | 0.060 |

Accessories
Locking Pin Ø 48/57
Bolt ISO 4014 M10 x 70-8.8 MU

| Item no. | Weight kg | |
|----------|-----------|--|
|----------|-----------|--|

111053 0.059

Locking Pin Ø 48/57

As tension-proof connection of standards with a diameter of 48 up to 57 mm.

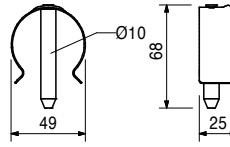

100719 0.060

Bolt ISO 4014 M10 x 70-8.8 MU

As tension-proof connection of standards for suspended scaffolds or lattice girders.

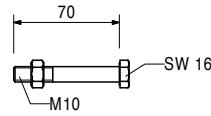
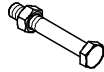

116306 1.700

Rosett Coupler UEV 180°

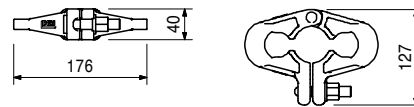
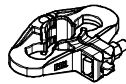

126453 1.630

Rosett Coupler UEV 90°

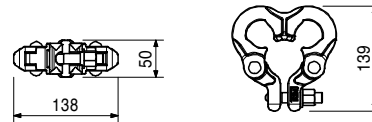
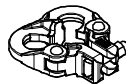

| Item no. | Weight kg |
|----------|-----------|
| 116176 | 15.000 |

Transportation Wheel UEW

For inserting in Connection Transportation Wheel UER (for Rosett) and Transportation Wheel ST 100.

Technical Data

Permissible load-bearing capacity 3.5 kN per wheel with spindle extension of Shoring Tower up to 30 cm.

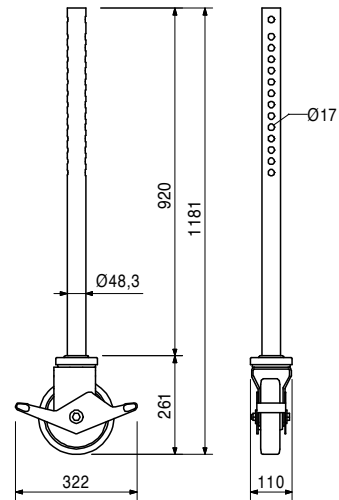
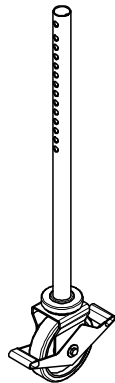

Accessories

| | |
|--------|-------|
| 116193 | 5.150 |
|--------|-------|

Connection Transportation Wheel UER

| | |
|--------|-------|
| 116193 | 5.150 |
|--------|-------|

Connection Transportation Wheel UER

Mounted on Standards UVR. Allows moving of complete frameworks.

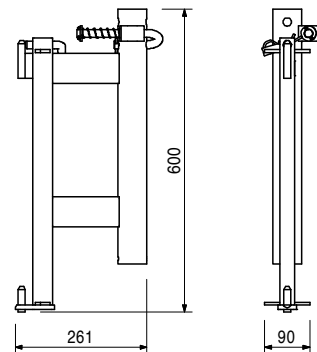
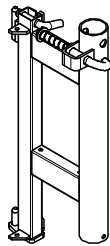

Accessories

| | |
|--------|--------|
| 116176 | 15.000 |
|--------|--------|

Transportation Wheel UEW

PERI UP Flex Shoring Tower



| Item no. | Weight kg |
|----------|-----------|
| 019200 | 162.000 |

Trolley with Winch

For moving towers and tables with MULTIPROP, Flex, Flex Plus and PD 8 with appropriate support for the system.

Note

Follow Instructions for Use!

Technical Data

Permissible load-bearing capacity 1.0 t.

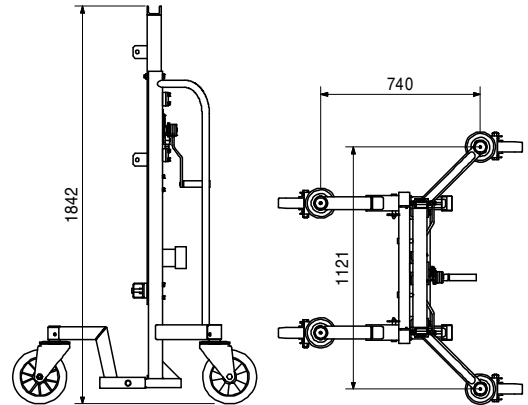
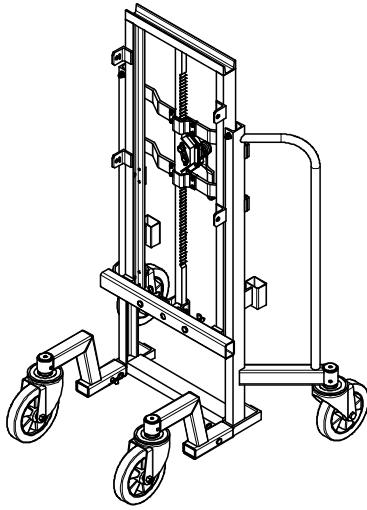

Accessories

| | |
|--------|--------|
| 118114 | 14.200 |
| 118115 | 11.000 |
| 130501 | 27.600 |

Connector MP – Trolley

Connector PD 8 – Trolley

Connector PERI UP – Trolley

| | |
|--------|--------|
| 130501 | 27.600 |
|--------|--------|

Connector PERI UP – Trolley

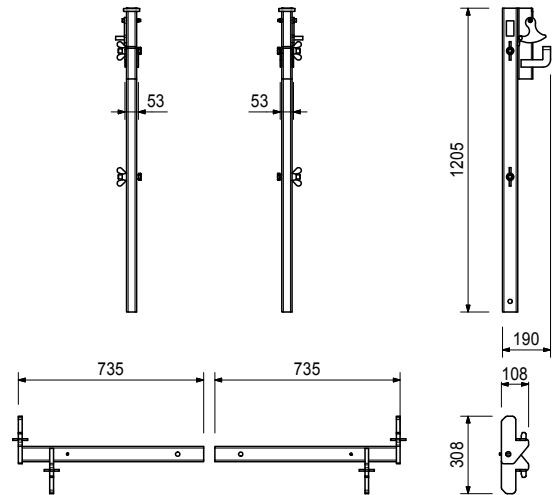
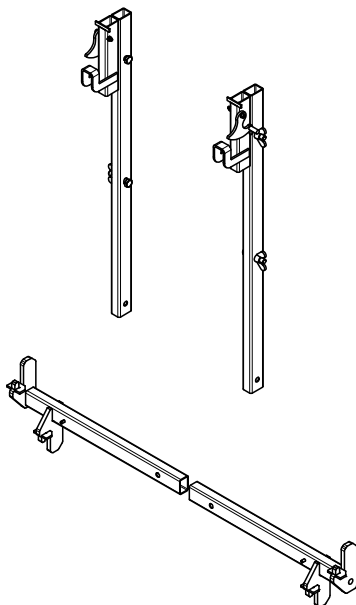

Comparison of components

As part of ongoing product optimisation, the following components have been replaced by 2nd generation components.

The following comparison tables describe the visible features of 1st and 2nd generation.



1st and 2nd generation components can be combined.

- The previous components
 - Standard UVR,
 - Steel Deck UDG
 are no longer available as new components.
- The optimised components
 - Standard UVR-2,
 - Steel Deck UDG-2
 are available under new article numbers.

Standard UVR

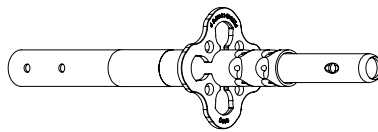

Standard UVR-2

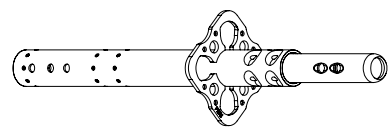

| | | |
|---|--|--|
| Tube | RO 48.3 mm x 3.2 mm | RO 48.3 mm x 2.7 mm , embossed points result in slight play on the joint. |
| Spigot tube connection | 2 rows, with 5 pinch points each | 2 rows, with 4 pinch points each |
| Rosette | 160 mm x 130 mm x 8 mm | 152 mm x 120 mm x 6 mm |
| Hole for suspended scaffold for fixing with screws and bolts M10 | 1 hole perm. F = 20 kN when fixed 1x | 2 holes perm. F = 15 kN when fixed 1x perm. F = 30 kN when fixed 2x |
| Marking | none | striped band at the top and bottom |
| Compatibility | Can be mixed based on geometric and static* compatibility. * Only applies when combined with UH Plus and UHV Plus horizontal ledgers. * The load tables shown in the Instructions for Assembly and Use for the Flex Heavy-Duty Prop HD and Shoring Tower Plus systems do not apply to use of the Standard UVR-2. Check the statics beforehand! | |

Steel Deck UDG

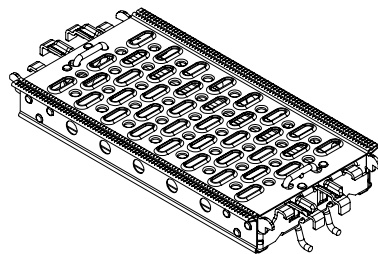

Steel Deck UDG-2

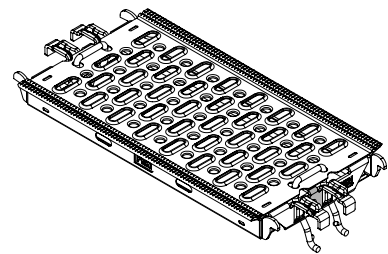

| | | |
|-----------------------|--|---|
| Deck assembly | riveted and welded | welded |
| Profile height | 65 mm, uniform | L 50 – 150: 45 mm L 200 – 250: 60 mm L 300: 70 mm |
| Marking | without | yellow clip on the front side |
| Compatibility | Can be mixed based on geometric and static* compatibility. Take *Load Class (perm. p) into account. | |

- The previous components
 - Top Standard UVH
 - Horizontal Ledger UH Plus
 are replaced by the optimised version and are no longer available in their previous form.
- The optimised components are available under their previous article number.

Top Standard UVH

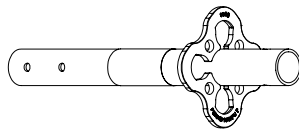

Top Standard UVH (2nd generation)

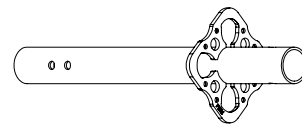

| | | |
|---|---|---|
| Tube | RO 48.3 mm x 3.2 mm | RO 48.3 mm x 3.2 mm |
| Rosette | 160 mm x 130 mm x 8 mm | 152 mm x 120 mm x 6 mm |
| Hole for suspended scaffold for fixing with screws and bolts M10 | 1 hole perm. F = 20 kN when fixed 1x | 2 holes perm. F = 15 kN when fixed 1x perm. F = 30 kN when fixed 2x |
| Compatibility | Can be mixed based on geometric and static compatibility. | |

Horizontal Ledger UH Plus

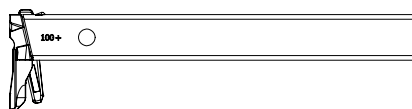

Horizontal Ledger UH Plus (2nd generation)

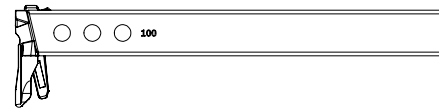

| | | |
|----------------------------|--|--|
| UBL assembly points | 2 x 1, for assembly of a Ledger Brace UBL | 2 x 3, for assembly of up to three Ledger Braces UBL When installing only one ledger brace preferably use the middle assembly point. UBL ledger braces can be mounted at very flat installation angles using the middle assembly point only. Check the geometry beforehand! |
| Compatibility | Can be mixed based on geometric and static compatibility | |

| Art. no. | Weight kg |
|----------|-----------|
| 133499 | 2.270 |

Base Standard UVB 25

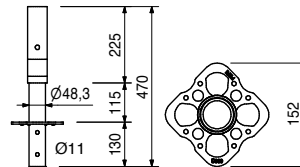

| | |
|--------|-------|
| 135187 | 3.590 |
|--------|-------|

Base Standard UVB 50

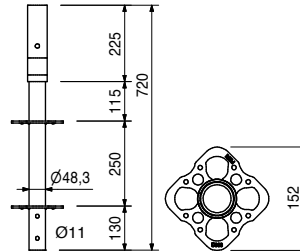

| | |
|--------|--------|
| 132219 | 2.480 |
| 132224 | 4.340 |
| 132229 | 6.180 |
| 132234 | 8.030 |
| 132239 | 11.700 |

Standards UVR-2

- Standard UVR-2 50
- Standard UVR-2 100
- Standard UVR-2 150
- Standard UVR-2 200
- Standard UVR-2 300

L

- 500
- 1000
- 1500
- 2000
- 3000

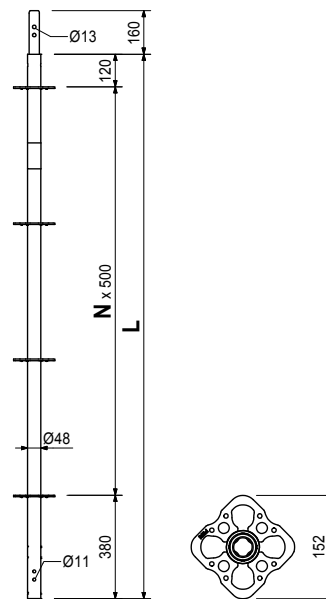
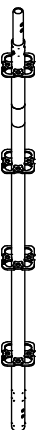

| | |
|--------|--------|
| 132479 | 3.330 |
| 132488 | 4.460 |
| 132492 | 5.580 |
| 132502 | 6.720 |
| 132505 | 7.860 |
| 132508 | 10.500 |
| 132511 | 12.900 |
| 132515 | 15.800 |

Steel Decks UDG-2 25

- Steel Deck UDG-2 25 x 50
- Steel Deck UDG-2 25 x 75
- Steel Deck UDG-2 25 x 100
- Steel Deck UDG-2 25 x 125
- Steel Deck UDG-2 25 x 150
- Steel Deck UDG-2 25 x 200
- Steel Deck UDG-2 25 x 250
- Steel Deck UDG-2 25 x 300

| X | perm. p [kN/m ²] | H |
|------|------------------------------|----|
| 500 | 6.0 | 45 |
| 750 | 6.0 | 45 |
| 1000 | 6.0 | 45 |
| 1250 | 6.0 | 45 |
| 1500 | 6.0 | 45 |
| 2000 | 6.0 | 60 |
| 2500 | 3.0 / 4.5* | 60 |
| 3000 | 3.0 | 70 |

Note

Values correspond with EN 12811-1

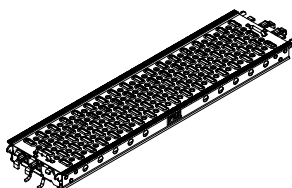
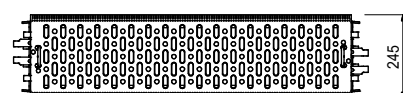
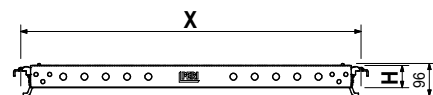

* Current Load Class 4, with extension of approval in 2020 Load Class 5.

| Art. no. | Weight kg |
|----------|-----------|
| 101309 | 2.090 |
| 100000 | 4.210 |
| 100003 | 6.310 |
| 100005 | 8.420 |
| 100007 | 10.500 |

Top Standards UVH (2nd generation)

Top Standard UVH 50

Top Standard UVH 100

Top Standard UVH 150

Top Standard UVH 200

Top Standard UVH 250

Without spigot for supporting head spindles.



| L |
|------|
| 500 |
| 1000 |
| 1500 |
| 2000 |
| 2500 |

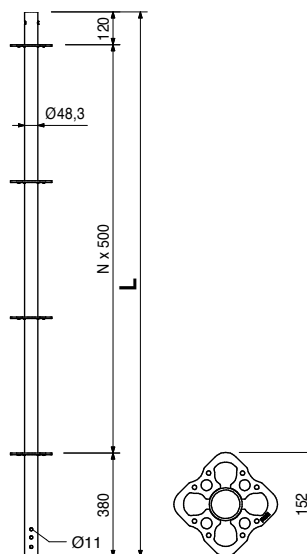

| | |
|--------|-------|
| 117195 | 6.060 |
|--------|-------|

Top Standard 125 (2nd generation)

Without spigot for supporting head spindles.

Reduces necessary spindle adjustments with

25 cm rosette spacing.

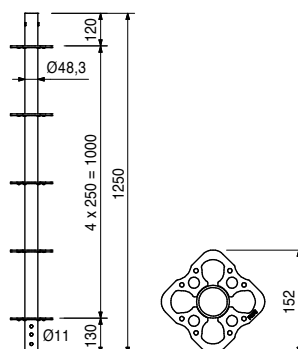
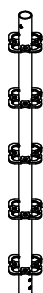

| | |
|--------|-------|
| 114613 | 1.410 |
| 114595 | 2.030 |
| 114629 | 2.690 |
| 114632 | 3.740 |
| 114638 | 4.510 |
| 114641 | 4.680 |
| 117032 | 5.340 |
| 114645 | 6.000 |
| 116356 | 6.660 |
| 114648 | 7.320 |
| 114651 | 8.650 |

Horizontal Ledgers UH Plus (2nd generation)

Horizontal Ledger UH 25 Plus

Horizontal Ledger UH 50 Plus

Horizontal Ledger UH 75 Plus

Horizontal Ledger UH 100 Plus

Horizontal Ledger UH 125 Plus

Horizontal Ledger UH 150 Plus

Horizontal Ledger UH 175 Plus

Horizontal Ledger UH 200 Plus

Horizontal Ledger UH 225 Plus

Horizontal Ledger UH 250 Plus

Horizontal Ledger UH 300 Plus

| L | X |
|------|------|
| 204 | 250 |
| 454 | 500 |
| 704 | 750 |
| 954 | 1000 |
| 1204 | 1250 |
| 1454 | 1500 |
| 1704 | 1750 |
| 1954 | 2000 |
| 2204 | 2250 |
| 2454 | 2500 |
| 2954 | 3000 |

Note

With length marking for easier identification.

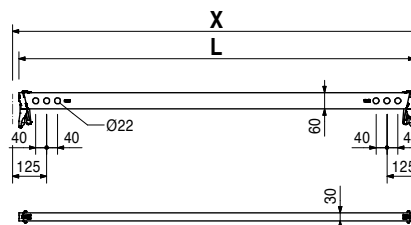
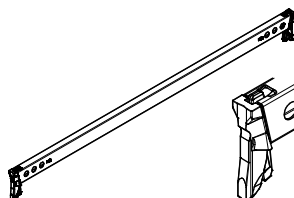

**The optimal System
for every Project and
every Requirement**



Wall Formwork



Column Formwork



Slab Formwork



Climbing Systems



Bridge Formwork



Tunnel Formwork



Shoring Systems



Construction Scaffold



Facade Scaffold



Industrial Scaffold



Access



Protection Scaffold



Safety Systems



System-Independent Accessories



Services



PERI GmbH
Formwork Scaffolding Engineering
 Rudolf-Diesel-Strasse 19
 89264 Weissenhorn
 Germany
 Tel. +49 (0)7309.950-0
 Fax +49 (0)7309.951-0
 info@peri.com
 www.peri.com