

# RS and RSS Push-Pull Props

Instructions for Assembly and Use – Standard Configuration

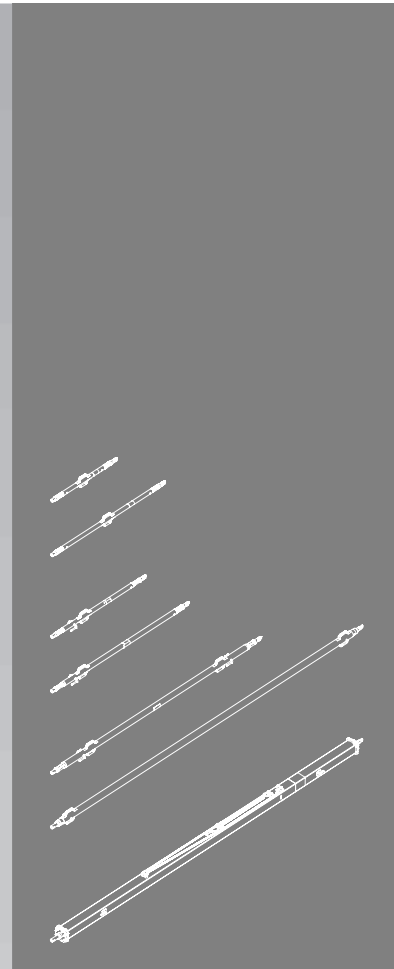

## Overview

RS main parts	1
RSS and AV main parts	2
Classification of push-pull prop connections	2
Key	3
Presentational reference	3

## Introduction

Target groups	4
Additional technical documentation	4
Intended use	5
Instructions for Use	5
Care and maintenance instructions	6

## Safety instructions

Cross-system	7
System-specific	7

## Standard configuration

A1	Storage and transportation	
	– Pallets	8
	– RS Push-Pull Props	9
	– RSS Push-Pull Props	11
	– Kickers AV	11
A2	Push-Pull Props RS 210 to RS 1000	
	– RS 210 and RS 260	12
	– RS 300 and RS 450	12
	– RS 650 and RS 1000	13
A3	Push-Pull Prop RS 1400	
	– Untighten the chain	14
	– Fixing the chain	15
	– Moving the push-pull prop	15
	– Adjusting the length	16
	– Erecting the push-pull prop	17
A4	Push-Pull Props RSS	
	– RSS Push-Pull Props	18
	– Kickers AV	18
A5	Base plates	
	– Base Plate RS	20
	– Base Plate RSS	21
A6	Wall connections	
	– MAXIMO and TRIO	22
	– DOMINO	22
	– LIWA	23
	– VARIO GT 24	23
	– DUO	24
	– UNO	24
A7	Column connections	
	– RAPID	25
	– QUATTRO	25
	– LICO	25
	– SRS	26
	– RUNDFLEX Plus-2	26
A8	Other connections	
	– MULTIPROP	27
	– Tubes	27
	– Steel Waler SRZ/SRU	27

## A9 Prefabricated concrete elements

– Quick Connector Head RS	28
– Adapter for Quick Connector Head RS	28
– Mounting the push-pull prop	29
– Dismantling	29

## Tables

B1	Load-bearing capacities	
	– RS Push-Pull Props	30
	– RSS Push-Pull Props and Kickers AV	31
B2	Base plate loads	
	– RS Push-Pull Prop on the base plate	32
B3	Prefabricated concrete element loads	
	– Quick Connector Head RS-2	34
	– Base Plate-3 RS 210-1400	34
	– Base Plate-2 RS 210-1400	34

## Components

RS and RSS Push-Pull Props	36
----------------------------	----

## RS main components

### RS 210

L = 1.30 – 2.10 m

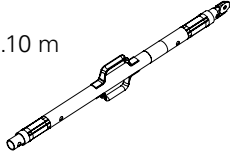

### RS 260

L = 2.30 – 2.60 m

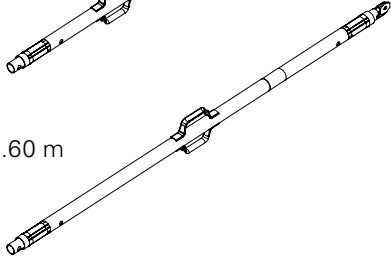

### RS 300

L = 1.90 – 3.00 m

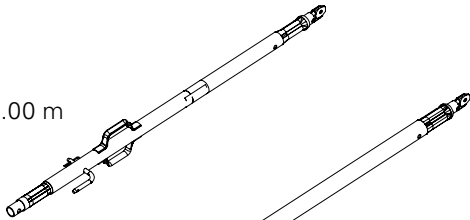

### RS 450

L = 2.80 – 4.50 m

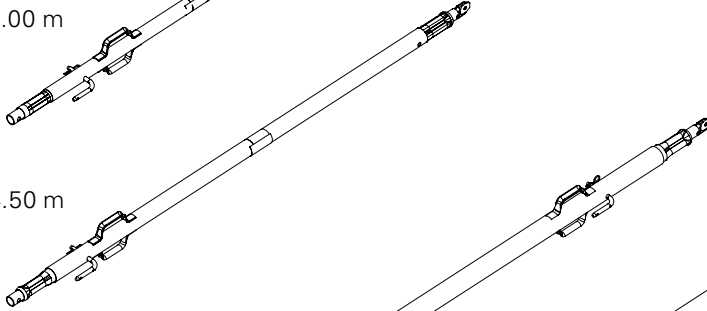

### RS 650

L = 4.30 – 6.50 m

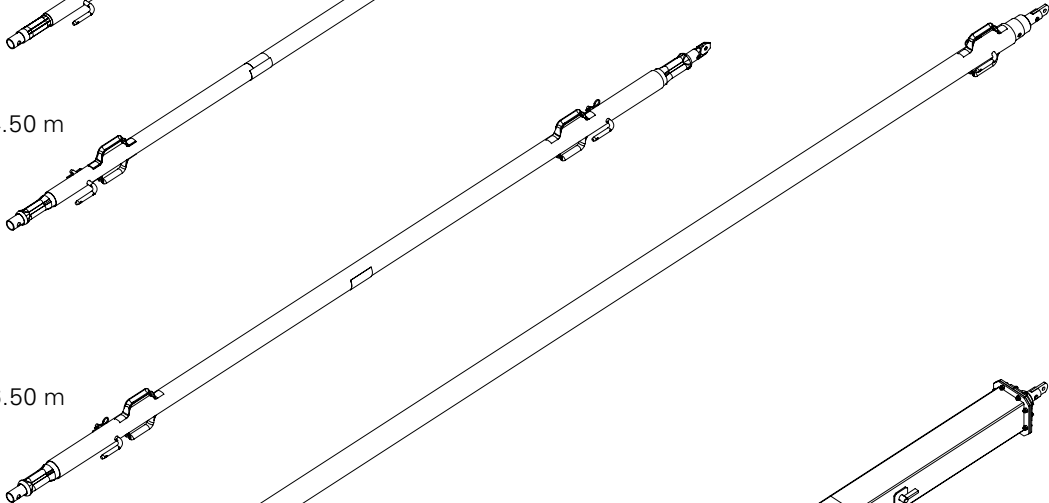

### RS 1000

L = 6.40 – 10.00 m

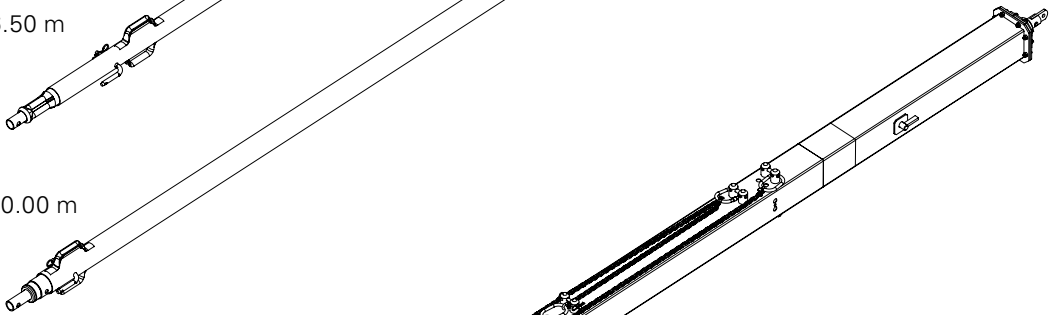

### RS 1400

L = 6.40 – 14.00 m

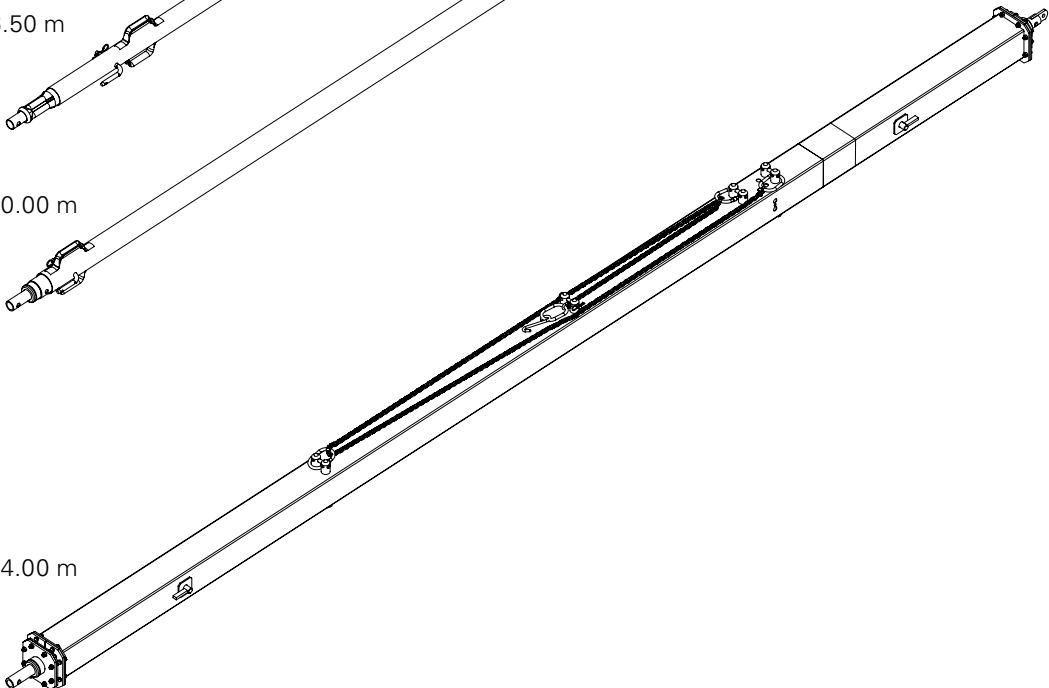

## RSS and AV main components

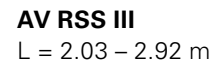
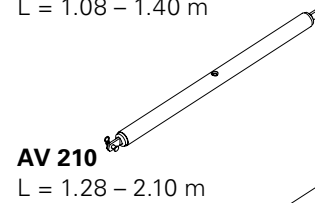
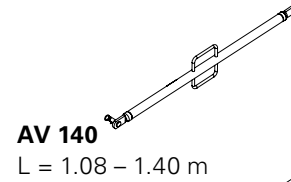
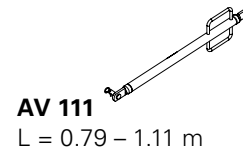
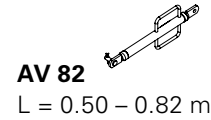
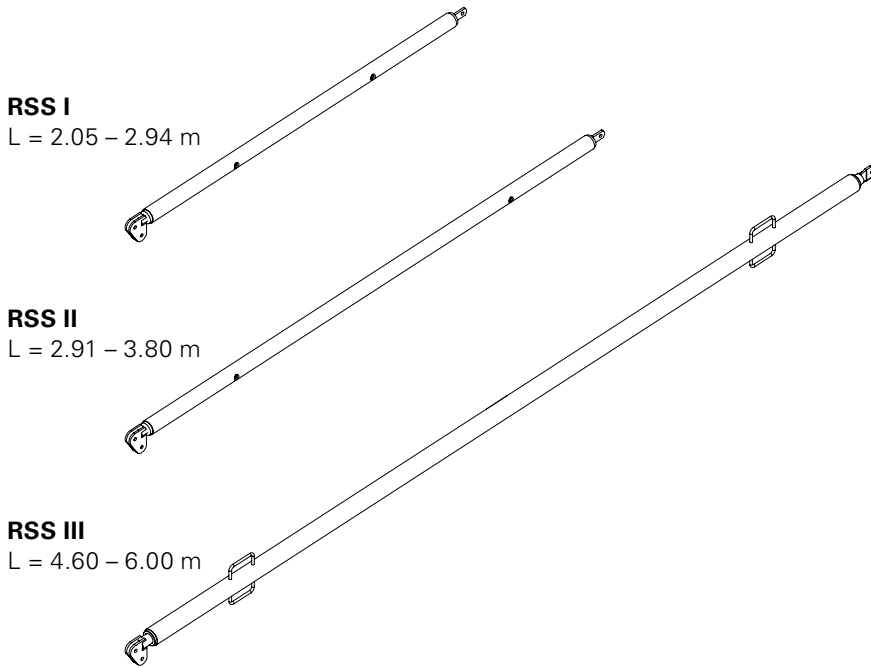

## Classification of push-pull prop connections

System	Wall	Column	Push-pull prop connections		
			in the system	on the ground	
			Item no.	RS Item no.	RSS Item no.
MAXIMO	x		023660	126666	106000
TRIO	x	x	023660		
DOMINO	x		127628		
LIWA	x		125329		
	x		117169		
GT 24/RUNDFLEX	x	x	028050		
	x	x	028070		
DUO	x		128294		
UNO	x	x	123559		
RAPID		x	037190		
QUATTRO		x	037530		
LICO		x	037530		
SRS		x	–		
RUNDFLEX Plus-2		x	–		
MULTIPROP	Slab Prop MP		129565		
	Alu Beam MPB 24		108213		
Tubes	Main Beam HDT		028080		
	HDR		022016		
GT 24/ VARIOKIT	Steel Waler SRZ/ SRU		028060		

## Key

### Pictogram | Definition

 Safety instructions

 Note

 Load-bearing point

 Visual check

 Tip

 Misapplication

 Correct application

### Units

Dimensions are usually given in cm. Other units of measure, e.g. m, are shown in the illustrations.

Exception: dimensions in the components overview are usually given in mm.

Load details are usually given in kg.

Other measurement units, e.g. t, are specified in the illustrations.

### Conventions

- Instructions are numbered with:  
1. .... , 2. .... , 3. ....
- The result of an instruction is shown by: →
- Position numbers are clearly provided for the individual components and are given in the drawing, e.g. **1**, in the text in brackets, for example (1).
- Multiple position numbers, i.e. alternative components, are represented with a slash, e.g. **1 / 2**.

### Arrows in the illustrations

- ➔ Arrow representing an action
- ➔ Forces

---

## Presentational reference

The illustration on the front cover of these instructions is understood to be a system representation only. The assembly steps presented in these Instructions for Assembly and Use are shown in the form of examples with only one component size. They are valid accordingly for all component sizes contained in the standard configuration.

For a better understanding, detailed illustrations are partly incomplete. The safety installations which have possibly not been featured in these detailed drawings must nevertheless still be available.

## Target groups

### Contractors

These Instructions for Assembly and Use are designed for contractors who use the formwork systems for

- assembling, modifying and dismantling operations, or use,
- them e.g. for concreting or,
- who have them used, e.g. for forming operations.

### Construction site coordinator

The Safety and Health Protection Coordinator\*

- is appointed by the client,
- must identify potential hazards during the planning phase,
- determines measures that provide protection against risks,
- creates a safety and health plan,
- coordinates the protective measures for the contractor and site personnel so that they do not endanger each other,
- monitors compliance with the protective measures.

### Competent persons

Due to the specialist knowledge gained from professional training, work experience and recent professional activity, the competent person has a reliable understanding of safety-related issues and can correctly carry out inspections. Depending on the complexity of the test to be undertaken, e.g. scope of testing, type of testing or the use of a certain measuring device, a range of specialist knowledge is necessary.

### Qualified persons

Formwork systems may only be assembled, modified or dismantled by personnel who are suitably qualified to do so. For the work to be carried out, the qualified persons must have received instructions\*\* which contain at least the following points:

- Explanation of the plan for the assembly, modification or dismantling of the formwork in an understandable form and language.
- Description of measures in order to safely assemble, modify or dismantle the scaffolding.
- Designation of the preventive measures to avoid the risk of persons and objects falling.

- Designation of the safety precautions in the event of changing weather conditions which could adversely affect the safety of the formwork system as well as the personnel concerned.
- Details regarding the permissible loads.
- Description of any other risks that are associated with the assembly, modification or dismantling procedures.



- **In other countries, ensure that the relevant national guidelines and regulations in the respective current version are complied with!**
- **If no country-specific regulations are available, it is recommended to proceed according to German rules and regulations.**

\* Valid in Germany: Regulations for Occupational Health and Safety on Construction Sites 30 (RAB 30).

\*\* Instructions are given by the contractor himself or a competent person selected by him.

## Additional technical documentation

- Instructions for Assembly and Use
  - Wall formwork
    - MAXIMO
    - TRIO
    - DOMINO
    - LIWA
    - VARIO GT 24
    - DUO
    - UNO
  - Column formwork
    - TRIO
    - VARIO GT 24
    - RAPID
    - QUATTRO
    - LICO
    - SRS
    - RUNDFLEX Plus-2
  - Other systems
    - MULTIPROP
    - PERI UP
    - HD 200 Heavy-Duty Prop
    - VARIOKIT VGK Cantilevered Parapet Bracket
- Instructions for Use
  - Pallets and Stacking Devices
  - Lifting Hook MAXIMO 1.5 t
  - Lifting Gear Combi MX
  - Lifting Gear MX
  - Concrete Cones
  - PERI Bio Clean
- Data Sheet: Anchor Bolt PERI 14/20 x 130
- PERI Design Tables – Formwork and Shoring
- Brochure: RS Push-Pull Props

## Intended use

PERI products have been designed for exclusive use in the industrial and commercial sectors by qualified users only.

These Instructions for Assembly and Use are based on the approval, type test and static calculation.

### Product Description – Push-Pull Props

- vertically support formwork systems, scaffolding systems and prefabricated concrete elements, and thus prevent them from falling over.
- transfer tension and compression forces.
- transfer wind loads.

These Instructions for Assembly and Use describe the standard configuration of the Push-Pull Props RS and the alternative Push-Pull Props RSS with Kickers AV.

With the RS Push-Pull Prop system, the Push-Pull Props RS are also mounted as kickers.

With the RSS Push-Pull Prop system, the Kickers AV are mounted as kickers.

### Features

- Safe and fast handling.
- Extendable – rough adjustment of the push-pull props in 10 cm increments. Exception: RS 1400 extendable in 20 cm increments.

- Fine adjustments – by means of the thread on the outer tube of the push-pull prop.
- Very long service life due to the hard-wearing corrosion protection.
- Low maintenance costs.
- Push-Pull Props RS can also be used as kickers.

### Standard configuration

- RS 210 L = 1.30 – 2.10 m
- RS 260 L = 2.30 – 2.60 m
- RS 300 L = 1.90 – 3.00 m
- RS 450 L = 2.80 – 4.50 m
- RS 650 L = 4.30 – 6.50 m
- RS 1000 L = 6.40 – 10.00 m
- RS 1400 L = 6.40 – 14.00 m

The following are shown:

- RS 210, RS 450, RS 650 in Section A2,
- RS 1400 in Section A3.

### Alternative Push-Pull Props

- RSS I L = 2.05 – 2.94 m
  - RSS II L = 2.91 – 3.80 m
  - RSS III L = 4.60 – 6.00 m
- RSS II is shown in Section A4.

### Kickers AV

- AV 82, AV 111, AV 140
  - AV 210
  - AV RSS III
- AV 140 is shown in Section A4.

### Product description – Quick Connector Head

With the Quick Connector Head RS and Adapter RS, push-pull props can be fixed to prefabricated concrete elements.

The Adapter RS tightly connects (friction-locked) the Quick Connector Head RS and the push-pull prop.

Fix corresponding fastener, e.g. screw-in sleeves, bolts or pigtail anchors, to horizontal prefabricated elements. Position and quantity of fasteners are calculated according to project specifications. Do not use the Quick Connector Head RS with the Push-Pull Prop RSS.

Connecting part

- for the formwork is the respective Quick Connector Head.
- for the push-pull prop is the Adapter for the Quick Connector Head RS.

---

## Instructions for Use

The use in a way not intended, deviating from the standard configuration or the intended use according to the Instructions for Assembly and Use, represents a misapplication with a potential safety risk, e.g. risk of falling.

Only PERI original components may be used. The use of other products and spare parts is not allowed.

Changes to PERI components are not permitted.

## Care and maintenance instructions

In order to maintain the value and operational readiness over the long term, clean the push-pull props after every use.

Some repair work may also be inevitable due to the tough working conditions. The following points should help to keep care and maintenance costs as low as possible.

Spray the push-pull props with water immediately after concreting; this avoids any time-consuming and costly cleaning operations.

Never use steel brushes or hard metal scrapers to clean powder-coated or galvanised components, e.g. elements and accessories.

Mechanical components, e.g. spindles or gear mechanisms, must be cleaned of dirt or concrete residue before and after use, and then greased with a suitable lubricant.

Provide suitable support for the components during cleaning so that no unintentional change in their position is possible.

Do not clean components when suspended on a crane.



## Cross-system

### General

The contractor must ensure that the Instructions for Assembly and Use supplied by PERI are available at all times and are understood by the site personnel.

These Instructions for Assembly and Use can be used as the basis for creating a risk assessment. The risk assessment is compiled by the contractor. These Instructions for Assembly and Use do not replace the risk assessment!

Always take into consideration and comply with the safety instructions and permissible loads.

For the application and inspection of PERI products, the current safety regulations and guidelines must be observed in the respective countries where they are being used.

Materials and working areas are to be inspected on a regular basis especially before each use and assembly for:

- signs of damage,
- stability and
- functionality.

Damaged components must be exchanged immediately on site and may no longer be used.

Safety components are to be removed only when they are no longer required.

Components provided by the contractor must conform with the characteristics required in these Instructions for Assembly and Use as well as all valid construction guidelines and standards. Unless otherwise indicated, this applies in particular to:

- Timber components: Strength Class C24 for Solid Wood according to EN 338.
- Scaffold tubes: galvanised steel tubes with minimum dimensions of  $\varnothing 48.3 \times 3.2$  mm according to EN 12811-1:2003 4.2.1.2.
- Scaffold tube couplings according to EN 74.

Deviations from the standard configuration are only permitted after a further risk assessment has been carried out by the contractor.

On the basis of this risk assessment, appropriate measures for working and operational safety as well as stability are to be determined.

Corresponding proof of stability can be provided by PERI on request if the risk assessment and resulting measures to be implemented are available.

Before and after exceptional occurrences that may have had an adverse effect regarding the safety of the formwork system, the contractor must immediately

- create another risk assessment, with appropriate measures for ensuring the stability of the formwork system being carried out based on the results,
- and arrange for an extraordinary inspection by a competent person. The aim of this inspection is to identify and rectify any damage in good time in order to guarantee the safe use of the formwork system.

Exceptional occurrences can include:

- accidents,
- longer periods of non-use,
- natural events, e.g. heavy rainfall, icing, heavy snowfall, storms or earthquakes.

### Assembly, modification and dismantling work

Assembly, modification or dismantling of formwork systems may only be carried out by qualified persons under the supervision of a competent person. The qualified persons must have received appropriate training for the work to be carried out with regard to specific risks and dangers.

On the basis of the risk assessment and Instructions for Assembly and Use, the contractor must create installation instructions in order to ensure safe assembly, modification and dismantling of the formwork system.

The contractor must ensure that the personal protective equipment required for the assembly, modification or dismantling of the system, e.g.

- safety helmet,
  - safety shoes,
  - safety gloves,
  - safety glasses,
- is available and used as intended.

If personal protective equipment against falling (PPE) is required or specified in local regulations, the contractor must determine appropriate attachment points on the basis of the risk assessment.

The personal protective equipment against falling to be used is determined by the contractor.

The contractor must

- provide safe working areas for site personnel which are to be reached through the provision of safe access ways. Areas of risk must be cordoned off and clearly marked.
- ensure the stability during all stages of construction, in particular during assembly, modification and dismantling of the formwork.
- ensure and prove that all loads are safely transferred.

### Utilisation

Every contractor who uses or allows formwork systems or sections of the formwork to be used, has the responsibility for ensuring that the equipment is in good condition.

If the formwork system is used successively or at the same time by several contractors, the health and safety coordinator must point out any possible mutual hazards and all work must be then coordinated.

### System-specific

Retract components only when the concrete has sufficiently hardened and the person in charge has given the go-ahead for striking to take place.

Base plates can only be loaded if the anchorage has sufficient concrete strength.

Secure all bolts with cotter pins.



- Store and transport components ensuring that no unintentional change in their position is possible.
- Use PERI lifting accessories and slings as well as only those lifting points provided on the component.
- Detach lifting accessories and slings from the lowered components only if they are in a stable position and no unintentional change is possible.
- Do not drop the components.
- During the moving procedure
  - ensure that components are picked up and set down so that unintentional falling over, falling apart, sliding, falling down or rolling is avoided.
  - no persons are allowed to remain under the suspended load.
- The access areas on the jobsite must be free of obstacles and tripping hazards as well as being slip-resistant.
- For transportation, the surface must have sufficient load-bearing capacity.
- Use original PERI storage and transport systems, e.g. crate pallets, pallets or stacking devices.

## Pallets

Pallets are one possibility for storing and transporting push-pull props. (Fig. A1.01)



- Use combi lifting gear or 4-sling lifting gear. On each pallet, attach a hook (12a) to one load-bearing point (1a).
  - Four load-bearing points per pallet. (Fig. A1.01)
- Follow Instructions for Use for pallet and stacking devices.

The pallets are available in two different sizes:

Pos.	Pallet	Item no.
1.1	RP-2 80 x 120	103434
1.2	RP-2 80 x 150	103429



All pallets (1.1/1.2) can be lifted using the longitudinal as well as front sides. (Fig. A1.01)

### Perm. load-bearing capacity of the pallets

- RP-2 80 x 120: 1.5 t
- RP-2 80 x 150: 1.5 t

### Crane sling angle $\leq 15^\circ$

4-sling lifting gear: length L = 3.0 m.



Push-pull props of the same type and size can also be placed one above the other between timbers and secured by means of steel bands.

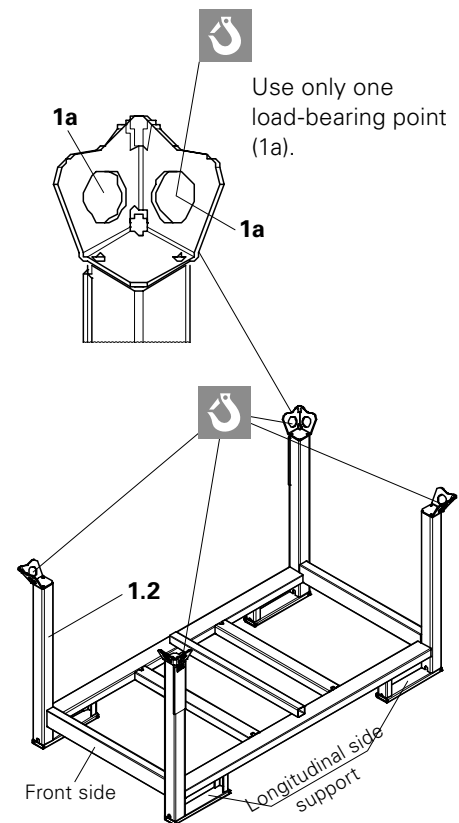

Fig. A1.01

## RS Push-Pull Props

In the following table, RS Push-Pull Props with the respective loading equipment and the number of push-pull props per loading equipment are defined taking into account the permissible load-bearing capacity of the pallets.

Push-pull prop	Item no.	Loading equipment	max. pieces/ pallet = width x height	Aids
<b>RS 210</b>	117466	RP-2 80 x 120	55 = 11 x 5	Timber, steel band
<b>RS 260</b>	118238	RP-2 80 x 150	55 = 11 x 5	Timber, steel band Layers stacked offset
<b>RS 300</b>	117467	RP-2 80 x 150	50 = 10 x 5	Timber, steel band
<b>RS 450</b>	117468	RP-2 80 x 150	45 = 9 x 5	Timber, steel band Levels stacked offset (Fig. A1.02)
<b>RS 650</b>	117469	RP-2 80 x 150	24 = 6 x 4	Timber, steel band
<b>RS 1000</b>	028990	RP-2 80 x 150	12 = 6 x 2	3x timbers per layer, (mount 1x centre and 2x outside of the pallet), Steel band
<b>RS 1400</b>	103800	RP-2 80 x 150	5 = 5 x 1	3x timber per layer, (mount 1x centre and 2x outside of the pallet), Steel band (Fig. A1.03 + A1.03a)

### RS 450

Stacked push-pull props in one pallet.  
(Fig. A1.02)

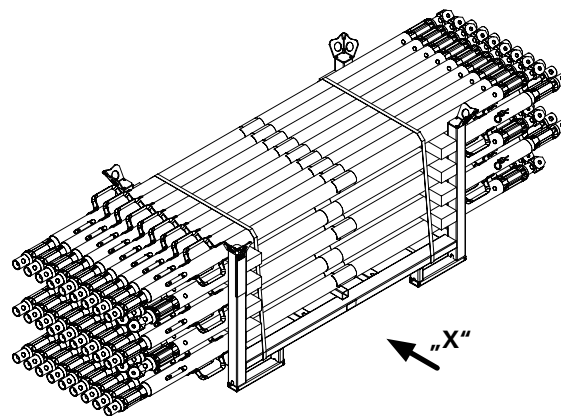

Fig. A1.02



Attention: with the Push-Pull Prop RS 450, the protrusion of the push-pull props is uneven due to the handle. As a result, the centre of gravity is not in the middle. Therefore, ensure that the layers are stacked in an offset arrangement. (Fig. A1.02a)

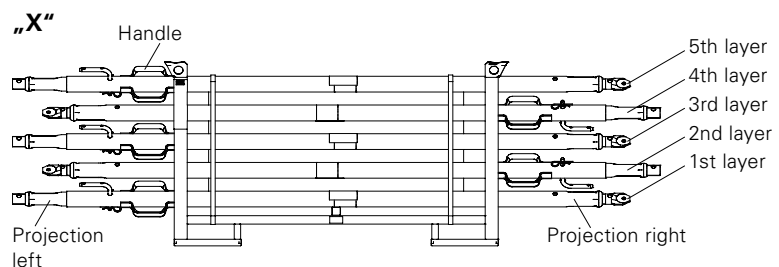

Fig. A1.02a

### RS and RSS Push-Pull Props

Instructions for Assembly and Use – Standard Configuration

## RS 1400

Stacked push-pull props in one pallet.  
(Fig. A1.03 + A1.03a)



Moving individual push-pull props, see  
Section A3.

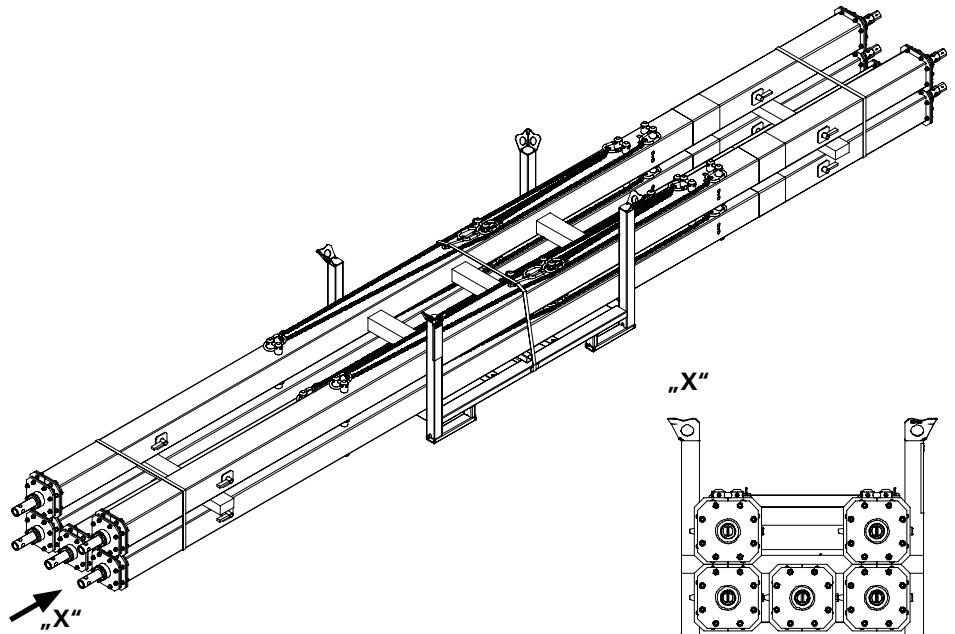

Fig. A1.03

Fig. A1.03a

## RSS Push-Pull Props

Push-pull prop	Item no.	Loading equipment	max. pieces/pallet = width x height	Aids
<b>RSS I</b>	028010	RP-2 80 x 150	54 = 9 x 6	Place timbers between every position and secure with steel bands.
<b>RSS II</b>	028020	RP-2 80 x 150	54 = 9 x 6	
<b>RSS III</b>	028030	RP-2 80 x 150	38 = 8 x 4 + 6 (Fig. A1.04)	

### RSS III

Stacked push-pull props in one pallet.  
(Fig. A1.04)

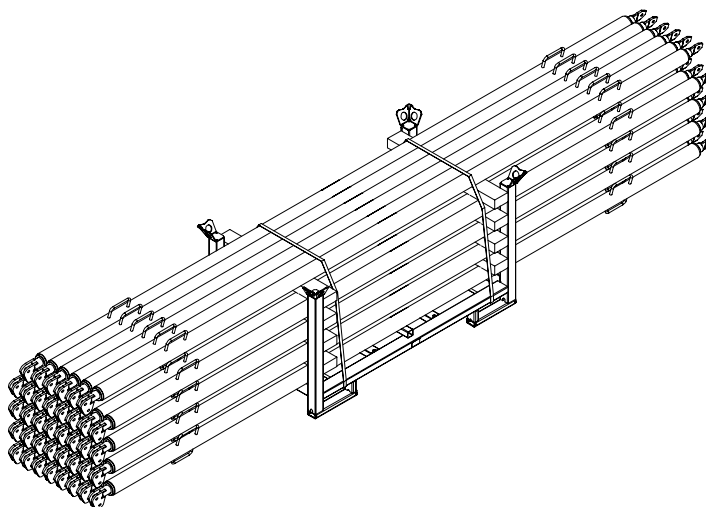

Fig. A1.04

## Kickers AV

Kickers	Item no.	Loading equipment	max. pieces/pallet = width x height	Aids
<b>AV 82</b>	123846	Crate Pallet K	200	
<b>AV 111</b>	123847	Crate Pallet K	200	
<b>AV 140</b>	028110	Crate Pallet K	144 - stacked	Cover plate, steel band
<b>AV 210</b>	108135	RP-2 80 x 120	54 = 9 x 6	Place timbers between every layer and secure with steel bands.
<b>AV RSS III</b>	028120	RP-2 80 x 150	54 = 9 x 6	



The size and number of push-pull props depends on the forces to be transferred, and must be product-specifically determined.

For load-bearing capacities, see Section B1.

- Rough adjustment of the length
  - Rough adjustments on Push-Pull Props RS 210 and RS 260 are not possible.
  - Rough adjustments on Push-Pull Props RS 300 and RS 450 are possible on one side.
  - Rough adjustments on Push-Pull Props RS 650 and RS 1000 are possible on both sides.
  - Adjustments should be done as symmetrically as possible.
- Fine adjustment of the length
  - All push-pull props can be adjusted with the spindle handle on the outer tube; in the process, the threaded spindles move simultaneously at the top and bottom.

## Adjusting the length



Hole spacing for the adjustment: 10 cm increments.

1. Rough adjustment at bottom
  - Remove cotter pins (1) and bolts (2).
  - Pull out inner tube until the required length is reached. Ensure that the holes are lying on top of each other.
  - Secure tube with bolts and cotter pins.
2. Rough adjustment at top, length-wise symmetrical to the bottom.
3. Turn the push-pull prop with the spindle handle.
  - Fine adjustment on both sides by means of the thread – top and bottom, simultaneously.



- Screw out the thread of the fine adjustment approx. 50 % which means fine adjustment can take place in both directions.
- The Push-Pull Prop RSS can be used instead of the Push-Pull Prop RS.

## RS 210 and RS 260

- No rough adjustment.
- Fine adjustment by means of the thread using the spindle handle – on both sides.

Push-pull prop	Item no.	Rough adjustment		Fine adjustment		
		Adjusting range [mm]	Length L <sub>1</sub> [m]	Adjusting range [mm]	min. L [m] Fig. A2.01a	max. L [m] Fig. A2.01b
RS 210	117466	–	–	800 = 2x 400	1.3	2.1
RS 260	118238	–	–	300 = 2x 150	2.3	2.6

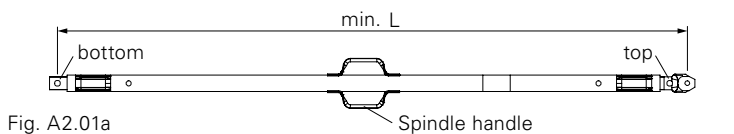

Fig. A2.01a

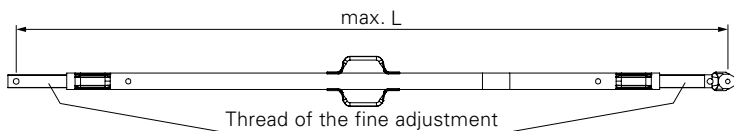
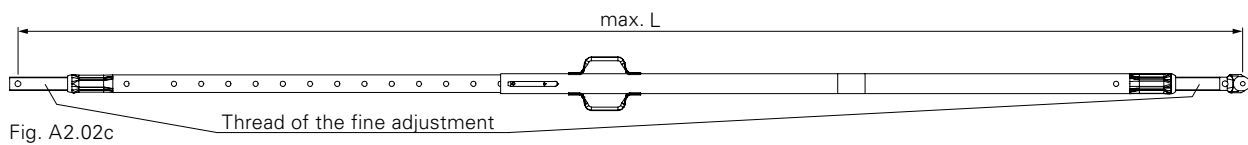
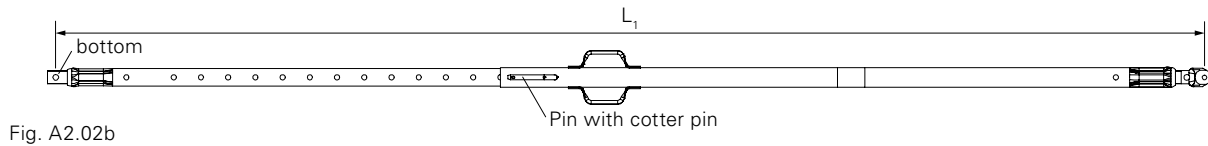
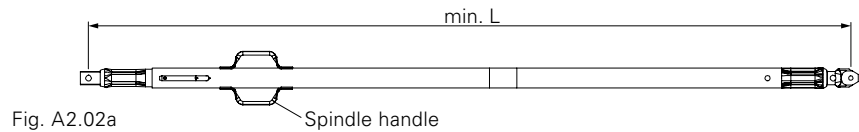

Fig. A2.01b

## RS 300 and RS 450

- Rough adjustment on one side using bolt and cotter pin on the outer and inner tubes – at the bottom.
- Fine adjustment by means of the thread using the spindle handle – on both sides.

Push-pull prop	Item no.	Rough adjustment		Fine adjustment		
		Adjusting range [mm]	Length L <sub>1</sub> [m] Fig. A2.02b	Adjusting range [mm]	min. L [m] Fig. A2.02a	max. L [m] Fig. A2.02c
RS 300	117467	800 = 8x 100	2.7	300 = 2x 150	1.9	3.0
RS 450	117468	1400 = 14x 100	4.2	300 = 2x 150	2.8	4.5



## RS 650 and RS 1000



- Risk of squeezing fingers! Adjust the length of the push-pull prop only in a horizontal position. When extending or retracting the inner tube, only hold the thread spindle not the inner tube.
- Never put a finger in a hole for holding purposes.
- Move the RS 1000 only by crane. Attach crane hooks with asymmetrical 2-sling lifting gear to the spindle handles.

- Rough adjustment on the outer and inner tubes using bolts and cotter pins. Possible on both sides – top and bottom.
- Fine adjustment by means of the thread using the spindle handle – on both sides.

Push-pull prop	Item no.	Rough adjustment		Fine adjustment		
		Adjusting range [mm]	Länge L <sub>1</sub> [m] Fig. A2.03b	Adjusting range [mm]	min. L [m] Fig. A2.03a	max. L [m] Fig. A2.03c
RS 650	147469	2000 = 2x 10x 100	6.3	200 = 2x 100	4.3	6.5
RS 1000	028990	3400 = 2x 10x 170	9.8	200 = 2x 100	6.4	10.0

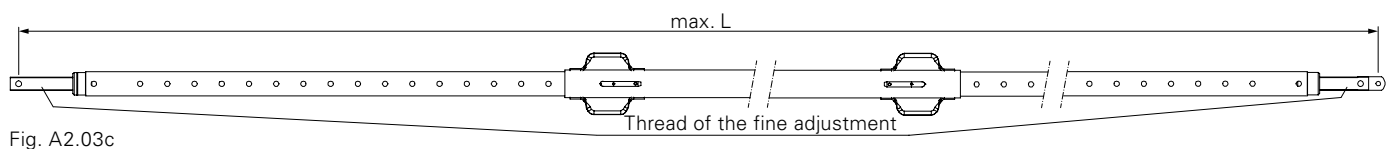
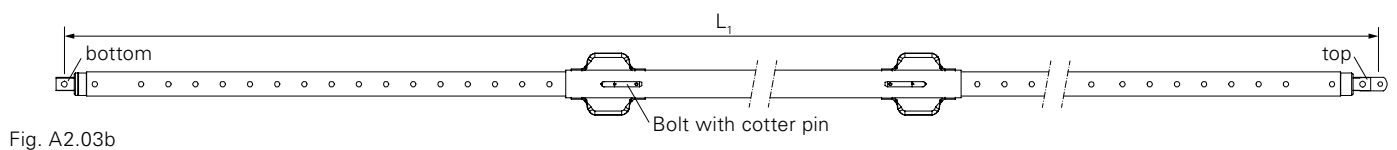
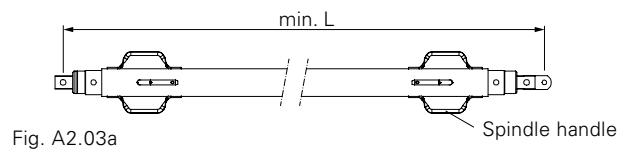

### RS and RSS Push-Pull Props

## Push-Pull Prop RS 1400



- Use personal protective equipment.
- Secure all bolts with cotter pins.
- Fix the loose end of the chain with the hook (10.5). As a result, the end of the chain is prevented from getting caught when the push-pull prop
  - is being unloaded or
  - moved on the jobsite or
  - being fixed to a formwork unit.
- Never suspend the hooks (10.5) in a crane hook.
- Attach Ring 1 (10.1) in the crane hook in order to move the push-pull prop.
- When transporting in a horizontal position, secure both crane hooks using the red rings only (10.2 + 10.3).

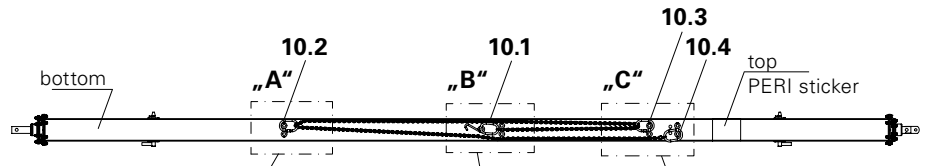

Fig. A3.01

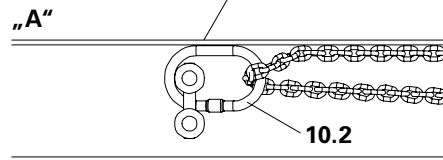

Fig. A3.01a

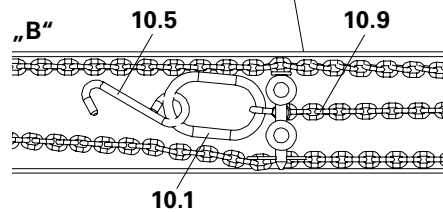

Fig. A3.01b

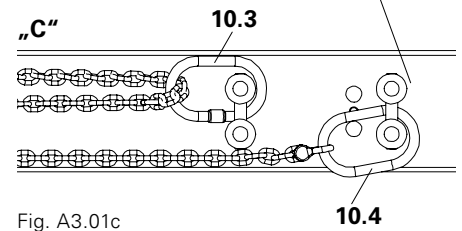

Fig. A3.01c



Is the chain (10.9) fixed as shown in the illustrations Fig. A3.01 + A3.01a/b/c?  
If the chain is not accurately inserted as shown in the illustrations, release the chain and re-attach to the push-pull prop.

Pos.	Component	Item no.
10	Push-Pull Prop RS 1400	103800
10.1	Ring 1 – black, loose, with hook (10.5)	
10.2	Ring 2 – red, fixed	
10.3	Ring 3 – red, fixed	
10.4	Ring 4 – black, fixed	
10.5	Hook – attached to Ring 1	
10.6	Spigot – 2x	
10.7	Bolt Ø 16 x 42	
10.8	Cotter Pin 4/1	
10.9	Chain	

## Untighten the chain

1. Remove cotter pins (10.8) and bolts (10.7) from the spigot (10.6). (Fig. A3.02a)
2. Lift out chain with Ring 1 and hook.
3. Re-attach bolts and cotter pins.
4. Insert Ring 1 (10.1) with hook (10.5) through Ring 3 (10.3) and pull through. (Fig. A3.02b)
5. Pull chain completely tight.
6. Insert Ring 1 (10.1) with hook (10.5) through Ring 2 (10.2) and pull through.
7. Pull chain completely tight.  
→ The chain (10.9) is released and hangs loosely in Ring 4 (10.4) on the push-pull prop. (Fig. A3.03)

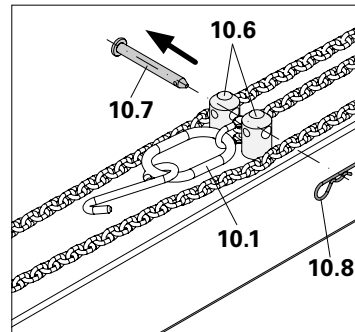

Fig. A3.02a

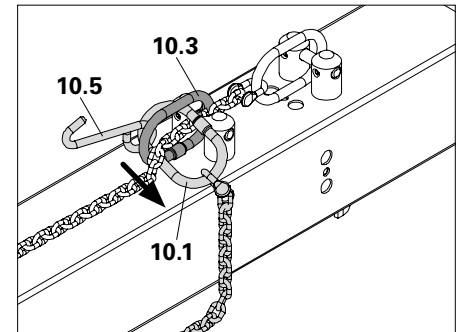

Fig. A3.02b

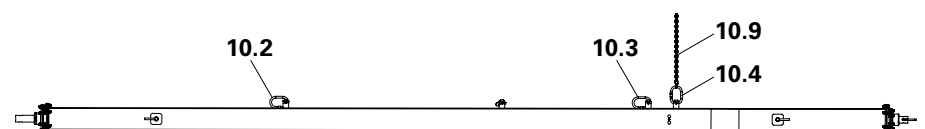

Fig. A3.03



## Fixing the chain

1. Remove bolts (10.7) and cotter pins (10.8).
2. Insert hook (10.5) and Ring 1 (10.1) through Ring 2 (10.2) and pull through. (Fig. A3.01a)
3. Pull chain (10.9) completely tight.
4. Insert hook (10.5) and Ring 1 (10.1) through Ring 3 (10.3) and pull through. (Fig. A3.04)
5. Pull chain completely tight.
6. Place chain between the two spigots (10.6).  
→ Ring 1 (10.1) is positioned in front of both spigots. (Fig. A3.05)
7. Insert bolts (10.7) through the holes of both spigots. (Fig. A3.05)  
→ Chain lies under the bolts.
8. Insert cotter pins (10.8) through the holes in the bolts. (Fig. A3.05)  
→ Chain is tensioned. (Fig. A3.07)

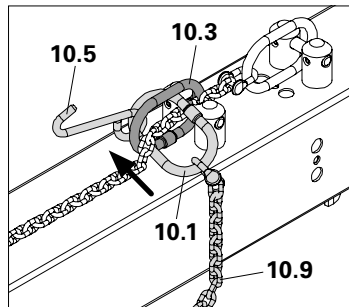

Fig. A3.04

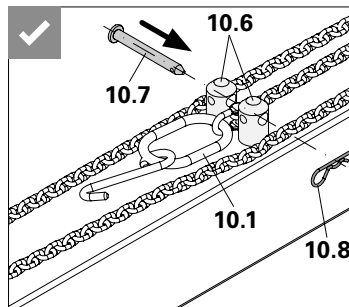

Fig. A3.05

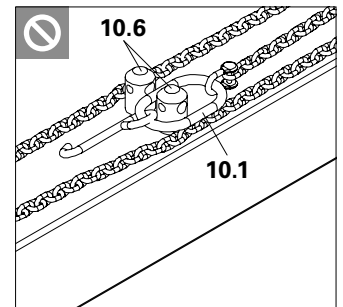

Fig. A3.06



Does the chain (10.9) lie between the two spigots (10.6)? (Fig. A3.05)

Do **not** position Ring 1 (10.1) between the two spigots (10.6). (Fig. A3.06)

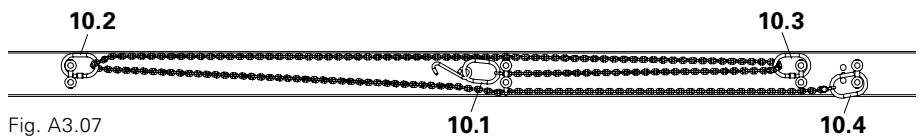

Fig. A3.07

## Moving the push-pull prop



- Crane sling angle on the 2-sling lifting gear  $\leq 30^\circ$ .
- Do not use textile lifting tackle, e.g. round slings, during moving operations.



- Ensure that Push-Pull Props RS 1400 are only moved individually and in a horizontal position on the rings (10.2 + 10.3).
- After being moved, the chain is then secured again.

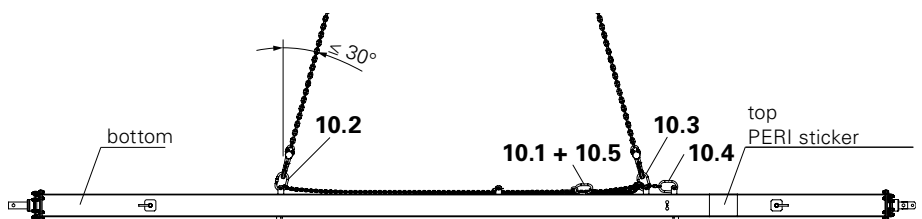

Fig. A3.08

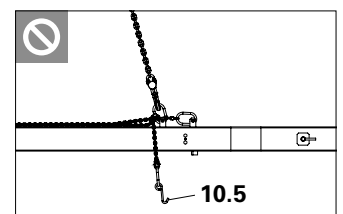

Fig. A3.09

### Preparation

1. Remove cotter pins and bolts.  
→ Ring 1 (10.1) is released.
2. Loosen the chain.
3. Firmly clamp the hook (10.5) in the chain.
4. Re-attach bolts and cotter pins.

### Moving

1. Attach one crane hook of the 2-sling lifting gear to Ring 2 (10.2).
2. The other crane hook is attached to Ring 3 (10.3).
3. Lift push-pull prop with crane. (Fig. A3.08)

Hook (10.5) must **not** hang down. (Fig. A3.09)  
During the moving process, firmly clamp the hook to the chain of the push-pull prop.

## Adjusting the length



- Risk of squeezing fingers! Adjust the length of the push-pull prop only in a horizontal position. When extending or retracting the inner tubes, only hold the thread spindle not the inner tubes.
- Never put a finger in a hole for holding purposes.



- The length of the push-pull prop to be adjusted is to be calculated according to project specifications.
- Ensure even distribution when adjusting the length of the inner tube top and bottom (rough adjustment).
- Unscrew the threaded spindle at the bottom (10.14) by only a few turns so that the push-pull prop can be attached to the base plate.

Pos.	Component	Item no.
10	Push-Pull Prop RS 1400	103800
10.10	Outer tube	
10.11	Inner tube top	
10.12	Inner tube bottom	
10.13	Threaded spindle top	
10.14	Threaded spindle bottom	



Screw out the threaded spindles (10.13 + 10.14) approx. 50 % which means fine adjustment can take place in both directions.

Push-pull prop	Item no.	Rough adjustment		Fine adjustment		
		Adjusting range [mm]	Length $L_1$ [m] Fig. A3.10b	Adjusting range [mm]	min. L [m] Fig. A3.10a	max. L [m] Fig. A3.10c
RS 1400	103800	6800 = 2 x 17 x 200	13.2	800 = 2x 400	6.4	14.0

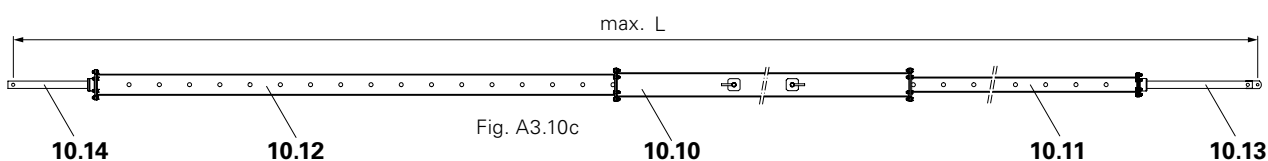
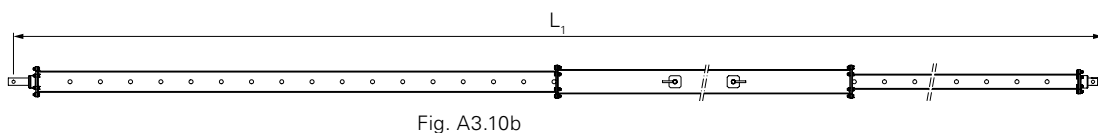
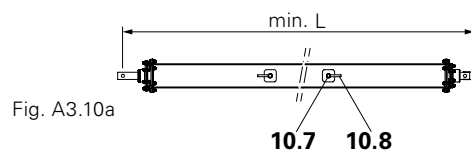

## Rough adjustment on one side



Hole spacing for the adjustment: 20 cm increments.

1. Remove cotter pins (10.8) and bolts (10.7).
  2. Pull out inner tube (10.11) up to the required length.
  3. Insert bolts (10.7) through the congruent holes of the inner and outer tubes (10.10).
  4. Insert cotter pins (10.8) through the holes in the bolts (10.7).
- The length has been adjusted and the inner and outer tubes are secured against moving.

(Fig. A3.10c + A3.11)

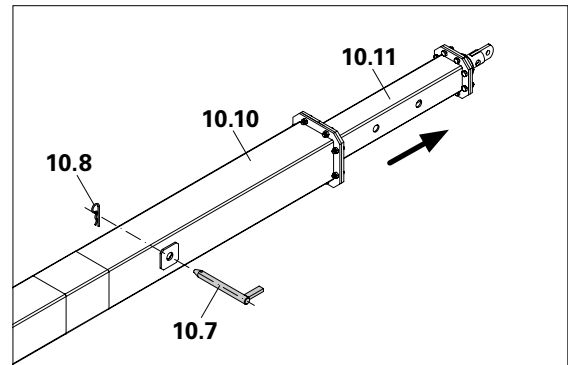

Fig. A3.11

## Fine adjustment



**Not until the push-pull prop has been fixed to the formwork and base plate.**

**Turn the push-pull prop on the outer tube.**

→ Fine adjustment on both sides above the threaded spindle – top and bottom simultaneously.

## Erecting the push-pull prop



**Perm. load-bearing capacity of the chain: 10 kN.**

1. Release the chain (10.9).
2. Attach Ring 1 (10.1) in the crane hook.
3. Fix base plate to the bottom end of the push-pull prop, see Section A5.
4. Attach push-pull prop to crane lifting gear and transport to the formwork element. (Fig. A3.12) One person must hold the push-pull prop from below so that the prop does not slide away.
5. Secure the top part of the push-pull prop to the formwork element using a brace connector of the respective system, see Section A6, A7 and A8.
6. Mount base plate on the ground, e.g. using Anchor Bolt PERI 14/20 x 130.
7. Turn the push-pull prop on the outer tube until the formwork element is in the required position, e.g. perpendicular.
  - Threaded spindles turn simultaneously.

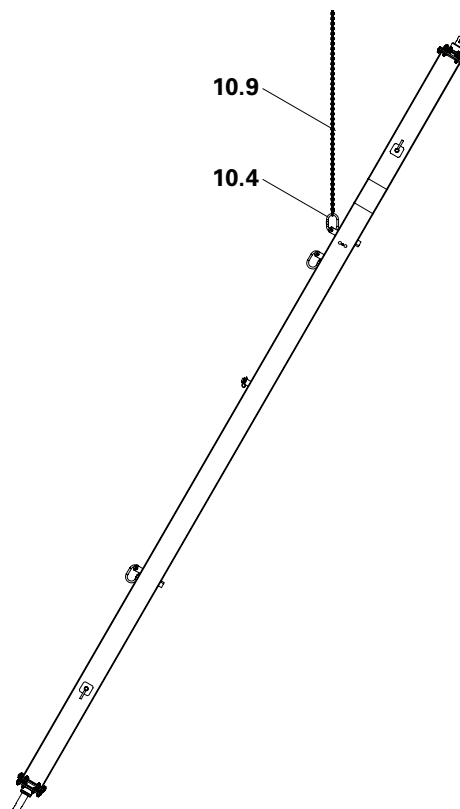

Fig. A3.12

## RSS Push-Pull Props

Push-pull prop	Item no.	Adjusting range [mm]	Fine adjustment	
			min. L [m] Fig. A4.02a	max. L [m] Fig. A4.02b
<b>RSS I *</b>	028010	890 = 2x 445	<b>2.05</b>	<b>2.94</b>
<b>RSS II *</b>	028020	890 = 2x 445	<b>2.91</b>	<b>3.80</b>
<b>RSS III</b>	028030	1400 = 2x 700	<b>4.60</b>	<b>6.00</b>

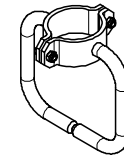

Fig. A4.01

\* Fix Spindle Handle (Item no. 113397 – Fig. A4.01) to push-pull prop.

### Adjusting the length

Symmetrically screw out the threaded spindles at the top and bottom until the required length is reached.

Turn installed push-pull prop with the spindle handle.

→ Threaded spindles turn simultaneously.

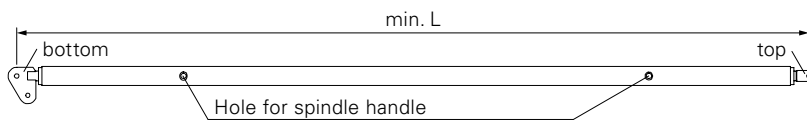

Fig. A4.02a

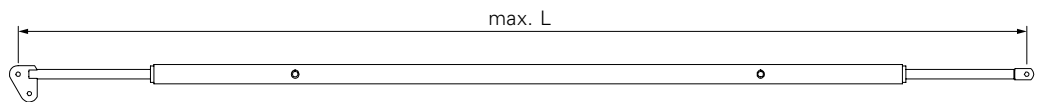

Fig. A4.02b



The Push-Pull Prop RS can also be used instead of the Push-Pull Prop RSS.

## Kickers AV

Push-pull prop	Item no.	Adjusting range [mm]	Fine adjustment	
			min. L [m] Fig. A4.03a	max. L [m] Fig. A4.03b
<b>AV 82</b>	057087	320 = 2x 160	<b>0.50</b>	<b>0.82</b>
<b>AV 111</b>	057088	320 = 2x 160	<b>0.79</b>	<b>1.11</b>
<b>AV 140</b>	028110	320 = 2x 160	<b>1.08</b>	<b>1.40</b>
<b>AV 210 *</b>	028135	820 = 2x 410	<b>1.28</b>	<b>2.10</b>
<b>AV RSS III *</b>	028120	890 = 2x 445	<b>2.03</b>	<b>2.92</b>

\* Fix Spindle Handle (Item no. 113397 – Fig. A4.01) to push-pull prop.

### Adjusting the length

Symmetrically screw out threaded spindles top and bottom until the required length is reached.

→ Threaded spindles turn simultaneously.

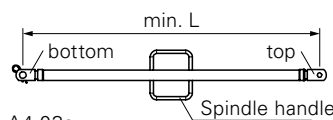

Fig. A4.03a

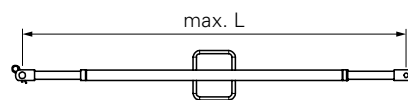

Fig. A4.03b





**Take into consideration data sheet for the anchor bolt.**



- Base plates are push-pull prop specific. There are two versions:
  - Base Plate RS for Push-Pull Props RS 210, RS 260, RS 300, RS 450, RS 650, RS 1000 and RS 1400,
  - Base Plate RSS for Push-Pull Props RSS I, RSS II and RSS III.
- Before the push-pull prop and kicker are attached to the base plate, roughly adjust the length and unscrew the threaded spindle (fine adjustment) using only a few turns.

## Base Plate RS

Pos.	Component	Item no.
40	Base Plate-3 RS	126666
41	Anchor Bolt PERI 14/20 x 130	124777

### Assembly

1. Fix the bottom part of the push-pull prop (RS) – here as kicker – with bolts (40.1) and cotter pins (40.2) to the back of the base plate (40).
2. Fix the bottom part of another push-pull prop – here as push-pull prop – with bolts (40.3) and cotter pins (40.4) to the base plate (40).
3. Fix brace connector to the formwork, see Instructions for Assembly and Use of the system.
4. Fix push-pull prop to the brace connector, see Sections A6, A7 and A8.
5. Mount base plate on a flat and sufficiently load-bearing surface area, e.g. using anchor bolts (41).

(Fig. A5.01)

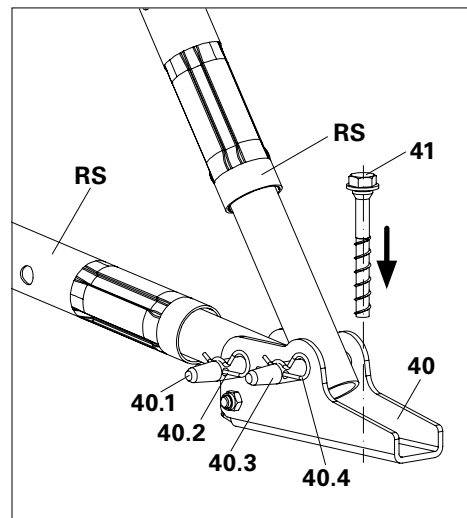

Fig. A5.01



Instead of the Base Plate-3, the RS 210-1400 (Item no. 126666) can also be used.

- Base Plate-2 for RS 1000/1400 (Item no. 102018) or
- Base Plate-2 for RS 210-1400 (Item no. 117343)

## Base Plate RSS

Pos.	Component	Item no.
5	Bolts $\varnothing$ 16 x 42	027170
6	Cotter Pin	018060
41	Anchor Bolt PERI 14/20 x 130	124777
42	Base Plate-2 RSS	106000

### Assembly

1. Fix connection lugs of the Push-Pull Prop RSS to the base plate using bolts (42.1) and cotter pins (42.2).
2. Fix the connection of the kicker to the rear hole of the connection lug using the bolts (5) and cotter pins (6).
3. Mount base plate on a flat and sufficiently load-bearing surface area, e.g. using anchor bolts (41).

(Fig. A5.02)

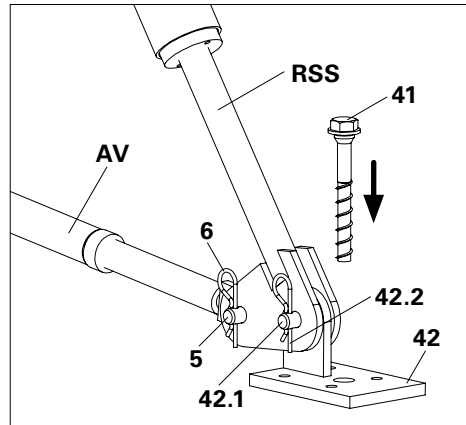

Fig. A5.02



Instead of the Base Plate-2 RSS (Item no. 106000), the Base Plate RSS (Item no. 028090) can also be used.



Wall connections are system-specific.

## MAXIMO and TRIO

Fix Brace Connector TRIO to the formwork element, see Instructions for Assembly and Use for the MAXIMO Panel Formwork and TRIO Panel Formwork systems.

Pos.	Component	Item no.
RS	Push-Pull Prop according to size	
20	Prop Connector-2	023660

- Horizontal assembly of the prop connector: connect Push-Pull Prop (RS) and connection lugs (20.1) with bolts (20.3) and cotter pins (20.4). (Fig. A6.01a)
- Vertical assembly of the prop connector: connect Push-Pull Prop (RS) and connection lugs (20.1) with bolts (20.3) and cotter pins (20.4). (Fig. A6.01b)

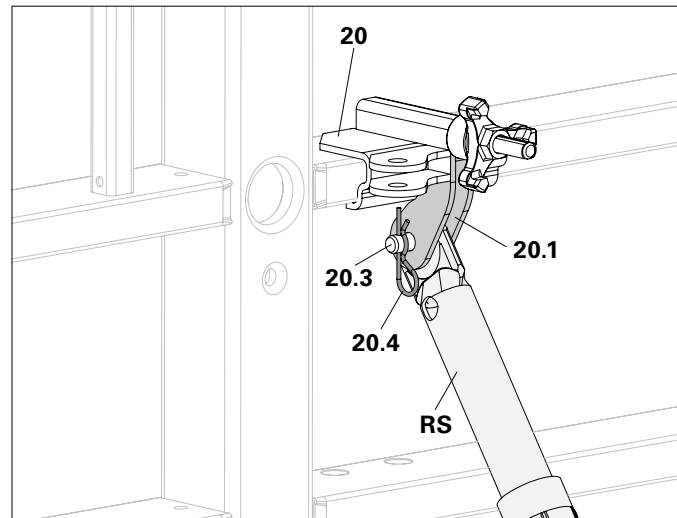

Fig. A6.01a

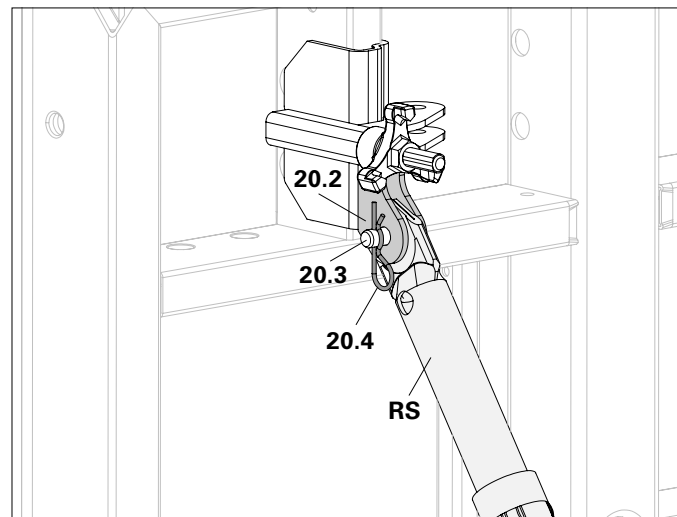

Fig. A6.01b

## DOMINO

Fix Brace Connector DRA to the formwork element, see Instructions for Assembly and Use for the DOMINO Panel Formwork system.

Pos.	Component	Item no.
21	DOMINO Brace Connector DRA-2	127628

Installation of the brace connector is only possible horizontally. Connect Push-Pull Prop (RS) and connection lugs (21.1) with bolts (21.2) and cotter pins (21.3). (Fig. A6.02)

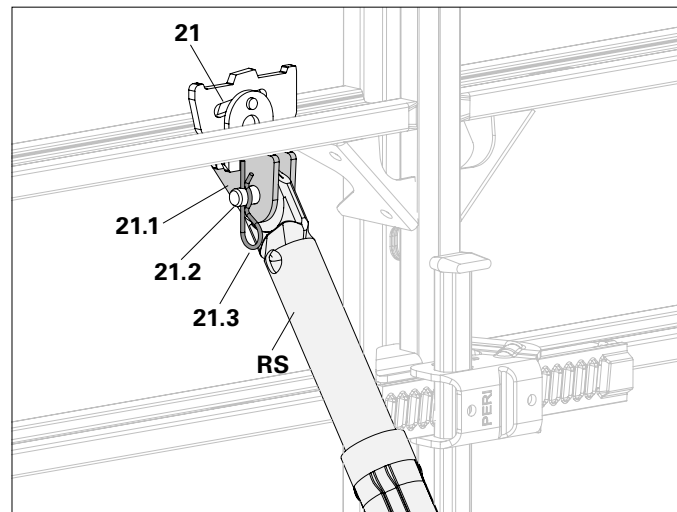

Fig. A6.02



## LIWA

Fix brace connector to the formwork element, see Instructions for Assembly and Use for the LIWA Panel Formwork system.

Pos.	Component	Item no.
22	Brace Connector LIWA-2	125329
23	Brace Connector LIWA	117169

- Horizontal assembly of the brace connector (22/23):
  - Connect Push-Pull Prop (RS) and connection lugs (22.1) with bolts (22.3) and cotter pins (22.4). (Fig. A6.03a)
  - Connect Push-Pull Prop (RS) and connection lugs (23.1) with bolts (23.2) and cotter pins (23.3). (Fig. A6.04)
- Vertical assembly of the Brace Connector LIWA-2 (22):
  - Connect Push-Pull Prop (RS) and connection lugs (22.2) with bolts (22.3) and cotter pins (22.4). (Fig. A6.03b)

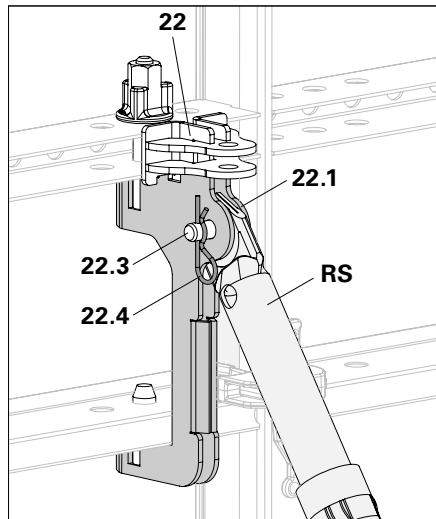

Fig. A6.03a

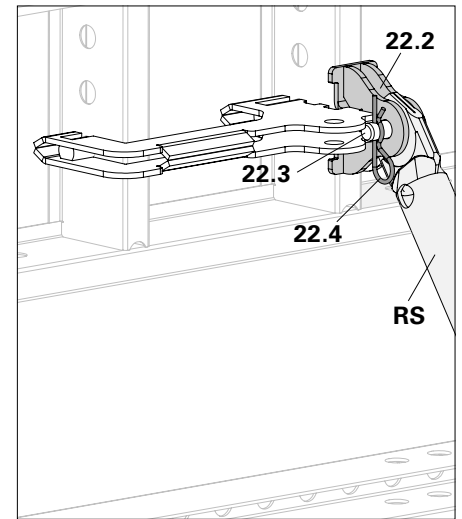

Fig. A6.03b

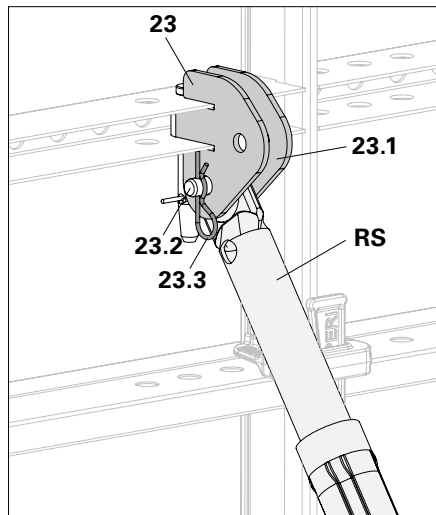

Fig. A6.04

## VARIO GT 24

Fix Girder Headpiece to the girder, see Instructions for Assembly and Use for the VARIO GT 24 Girder Wall Formwork system.

Pos.	Component	Item no.
24	Girder Headpiece 24	028050
25	Girder Headpiece 24/A	028070

Installation of the girder headpiece is only possible vertically.

- Install Girder Headpiece (24) within the girder: connect Push-Pull Prop (RS) to connection lugs (24.1) using bolts (24.2) and cotter pins (24.3). (Fig. A6.05)
- Connect the Girder Headpiece (25) to the extension splices of two girders: connect Push-Pull Prop (RS) to connection lugs (25.1) using bolts (25.2) and cotter pins (25.3). (Fig. A6.06)

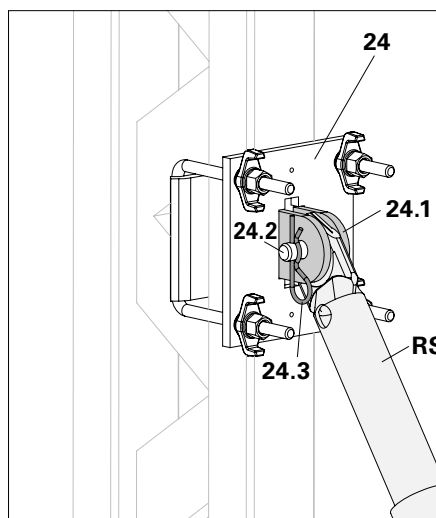

Fig. A6.05

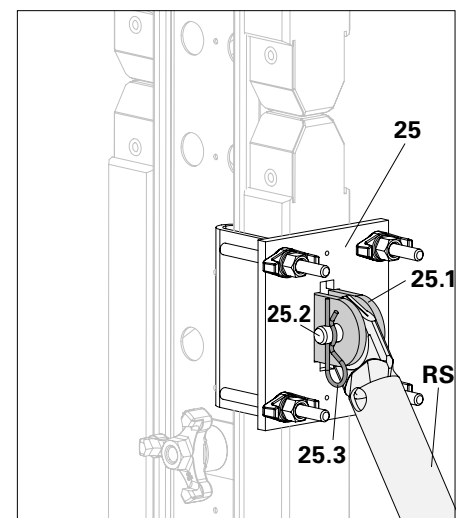

Fig. A6.06

## DUO

Fix Brace Connector DUO to the formwork element, see Instructions for Assembly and Use for the DUO Formwork system.

Pos.	Component	Item no.
26	Brace Connector DUO	128294

Installation of the brace connector (26) simultaneously on the horizontal and vertical struts.

Connect Push-Pull Prop (RS) and connection lugs (26.1) with bolts (26.2) and cotter pins (26.3). (Fig. A6.07)

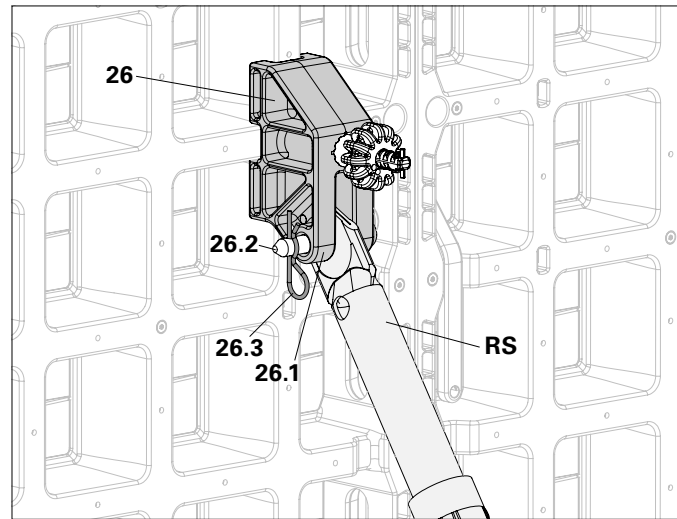

Fig. A6.07

## UNO

Fix Brace Connector UNO to the formwork element, see Instructions for Assembly and Use for the UNO Formwork system.

Pos.	Component	Item no.
27	Brace Connector UNO	123559

Installation of the brace connector (27) is only possible on the vertical struts of the UNO element.

Connect Push-Pull Prop (RS) and connection lugs (27.1) with bolts (27.2) and cotter pins (27.3). (Fig. A6.08)

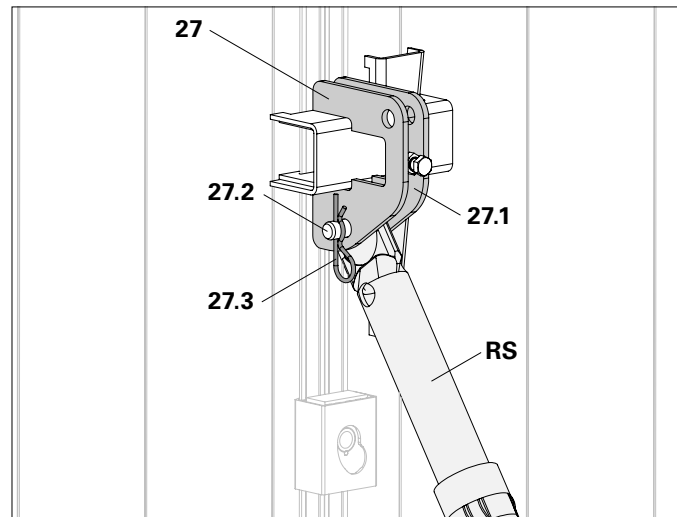

Fig. A6.08

## RAPID

Fix the connection of the brace connector to the formwork element or column, see Instructions for Assembly and Use for the RAPID Column Formwork system.

Pos.	Component	Item no.
28	Brace Connector-3 Rapid	037190

Connect Push-Pull Prop (RS) and connection lugs (28.1) with bolts (28.2) and cotter pins (28.3). (Fig. A7.01)

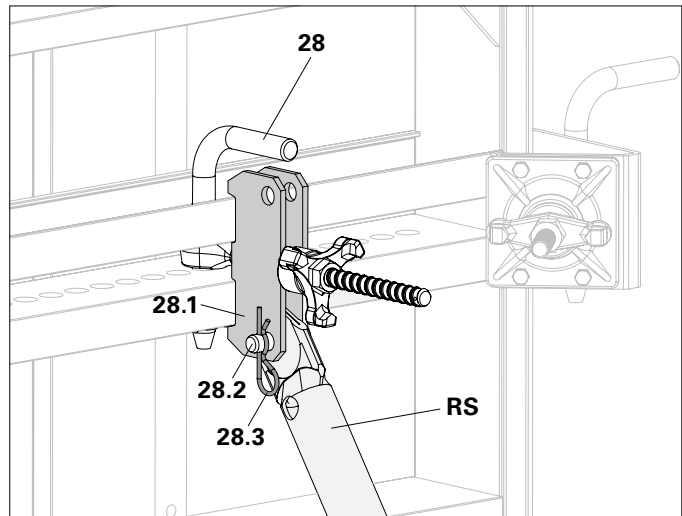

Fig. A7.01

## QUATTRO

Fix brace connector to the formwork element or column, see Instructions for Assembly and Use of the QUATTRO Column Formwork system.

Pos.	Component	Item no.
29	QUATTRO Brace Connector QR	037530

Connect Push-Pull Prop (RS) and connection lugs (29.1) with bolts (29.2) and cotter pins (29.3). (Fig. A7.02)

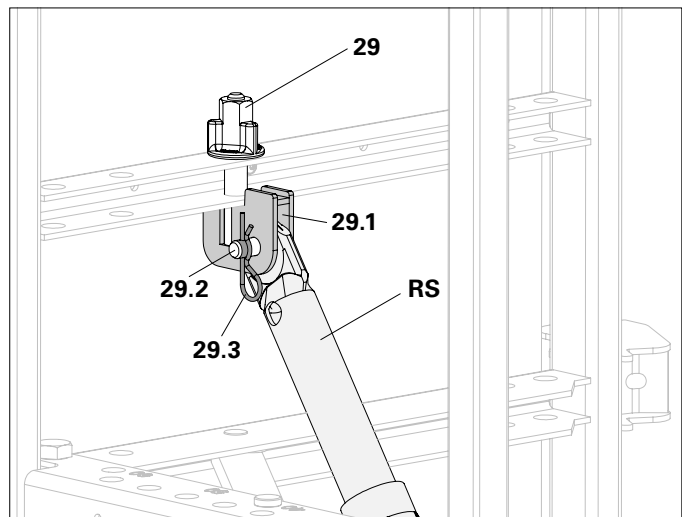

Fig. A7.02

## LICO

Fix brace connector to the formwork element/column, see Instructions for Assembly and Use for the LICO Column Formwork system.

Pos.	Component	Item no.
29	QUATTRO Brace Connector QR	037530

Connect Push-Pull Prop (RS) and connection lugs (29.1) with bolts (29.2) and cotter pins (29.3). (Fig. A7.03)

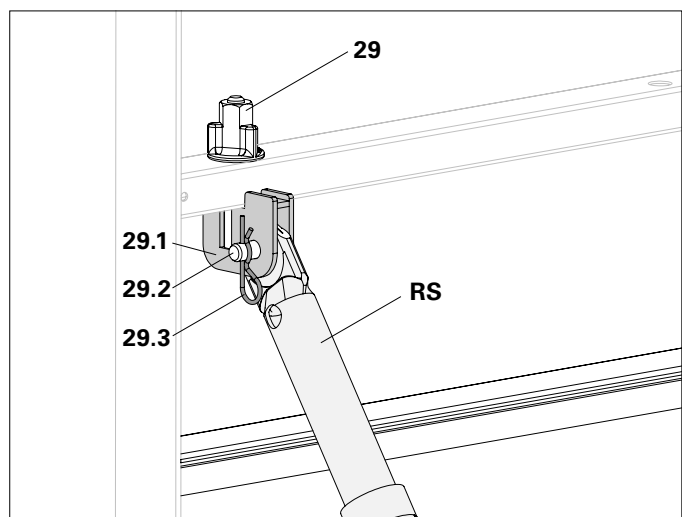

Fig. A7.03

## SRS

Without any additional components as brace connector.

Pos.	Component	Item no.
5	Bolts Ø 16 x 42	027170
6	Cotter Pin 4/1	018060

Fix Push-Pull Prop (RS) between the connection lugs (SRS) of the SRS Circular Column Formwork using bolts (5) and cotter pins (6). (Fig. A7.04)

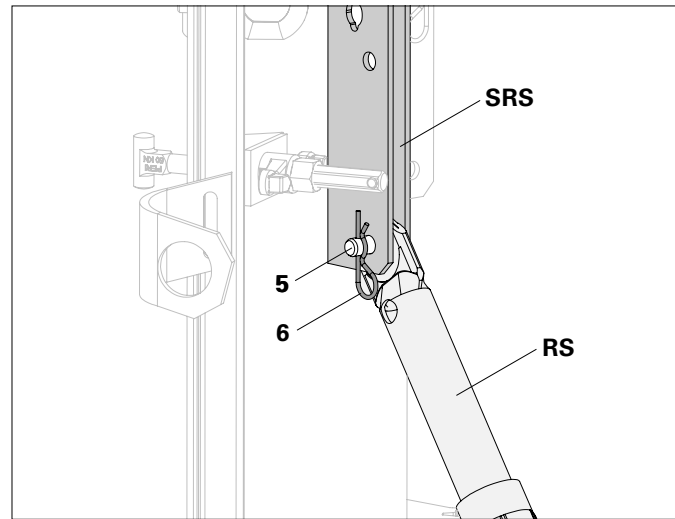

Fig. A7.04

## RUNDFLEX

The connection of the push-pull prop is identical with the VARIO GT 24 Girder Wall Formwork, see Section A6, VARIO GT 24.  
(not shown)

## RUNDFLEX Plus-2

Without any additional components as brace connector.

Pos.	Component	Item no.
5	Bolts Ø 16 x 42	027170
6	Cotter Pin 4/1	018060

Fix Push-Pull Prop (RS) between the connection lugs of the connection of the RUNDFLEX Plus-2 Circular Column Formwork using bolts (5) and cotter pins (6).

See Instructions for Assembly and Use for the RUNDFLEX Plus-2 system.  
(not shown)

## MULTIPROP

Fix the Brace Connector MPR to the element of the Slab Prop MP or Brace Connector MPB 24 on the Alu Beam MPB 24.

See Instructions for Assembly and Use of the MULTIPROP system.

Pos.	Component	Item no.
30	Brace Connector MPR	129565
31	Brace Connector MPB 24	108213

- Connect Push-Pull Prop (RS) and connection lugs (30.1) with bolts (30.2) and cotter pins (30.3). (Fig. A8.01)
- Connect Push-Pull Prop (RS) and connection lugs (31.1) with bolts (31.2) and cotter pins (31.3). (Fig. A8.02)

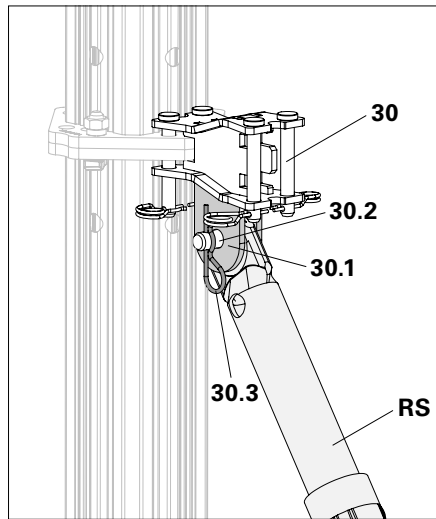

Fig. A8.01

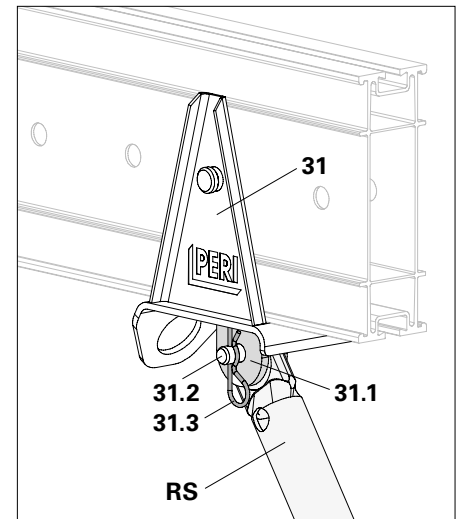

Fig. A8.02

## Main Beam HDT

Fix the connection of the Connector Kicker AV to the bottom chord of the top beam.

Pos.	Component	Item no.
32	Connector Kicker AV	028080

Install Push-Pull Prop (RS) between the connection lugs of the connection of the Connector Kicker AV (32) using bolts and cotter pins.

See Instructions for Assembly and Use of the HD 200 Heavy-Duty Prop system.

(not shown)

## Tubes

Fix Brace Connector HDR to the tubes with  $\varnothing$  48 mm, e.g. of scaffolding or heavy-duty props. See Instructions for Assembly and Use for the HD 200 Heavy-Duty Prop system.

Pos.	Component	Item no.
33	Brace Connector HDR	022016

Connect Push-Pull Prop (RS) and connection lugs (33.1) with bolts (33.2) and cotter pins (33.3). (Fig. A8.03)

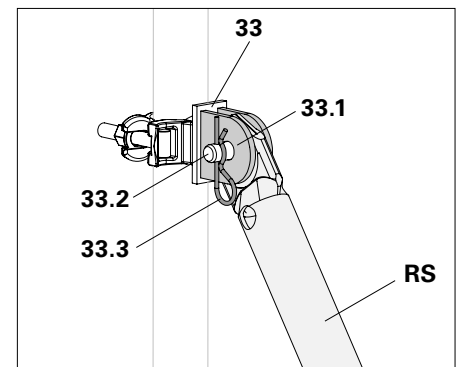

Fig. A8.03

## Steel Waler SRZ/SRU

Fix the Wedge Headpiece SRZ/SRU to the Steel Waler SRZ/SRU, e.g. VARIOKIT VGK Parapet Track.

See Instructions for Assembly and Use for the VARIO GT 24 system.

Pos.	Component	Item no.
34	Wedge Headpiece SRZ/SRU	028060

Connect Push-Pull Prop (RS) and connection lugs (34.1) with bolts (34.2) and cotter pins (34.3). (Fig. A8.04)

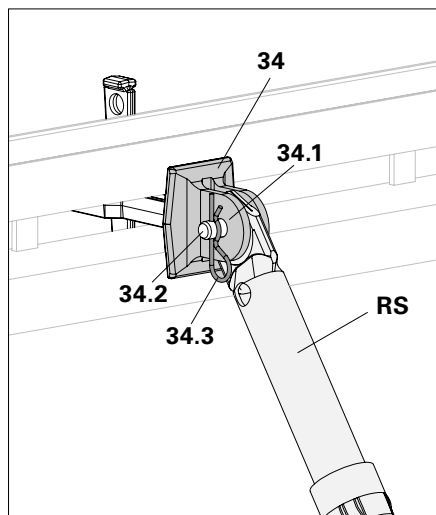

Fig. A8.04

## Quick Connector Head RS



### Quick Connector Head RS

- only mount on prefabricated concrete elements.
- do not use with wall and column formwork.
- only use with Push-Pull Props RS 210, RS 260, RS 300 and RS 450. With longer push-pull props (RS 650, RS 1000 and RS 1400) the mounting is not secure.
- do not use with Push-Pull Props RSS.
- only use in an angle range from 20° to 60°, see Section B3.

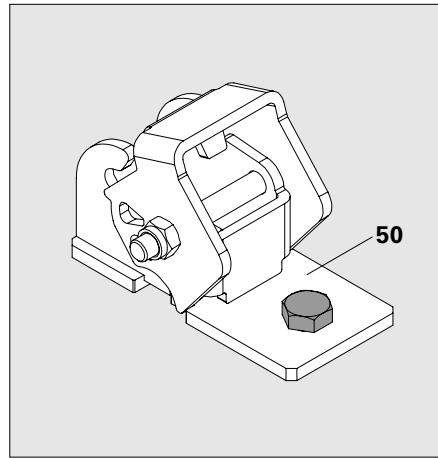

Fig. A9.01a



Instead of the Quick Connector Head RS-2 (Item no. 127190), the Quick Connector Head RS (Item no. 117470) can also be used.



The position and number of fastening elements for the Quick Connector Head is determined according to the respective project.

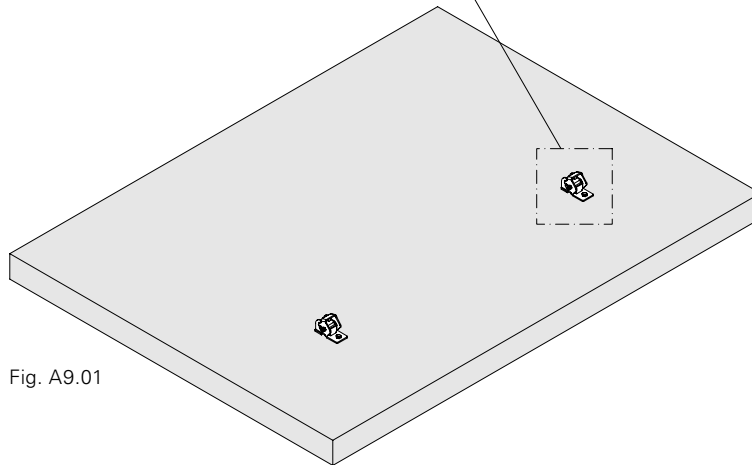

Fig. A9.01

Pos.	Component	Item no.
50	Quick Connector Head RS-2	127190

Fix Quick Connector Head (50) with suitable fastening means, e.g. screw-in sleeves and bolts or reliable pigtail anchors, preferably to horizontally positioned prefabricated components. (Fig. A9.01 + A9.01a)

## Adapter for Quick Connector Head RS

The adapter (52) tightly connects (friction-locked) the Quick Connector Head RS and push-pull prop.

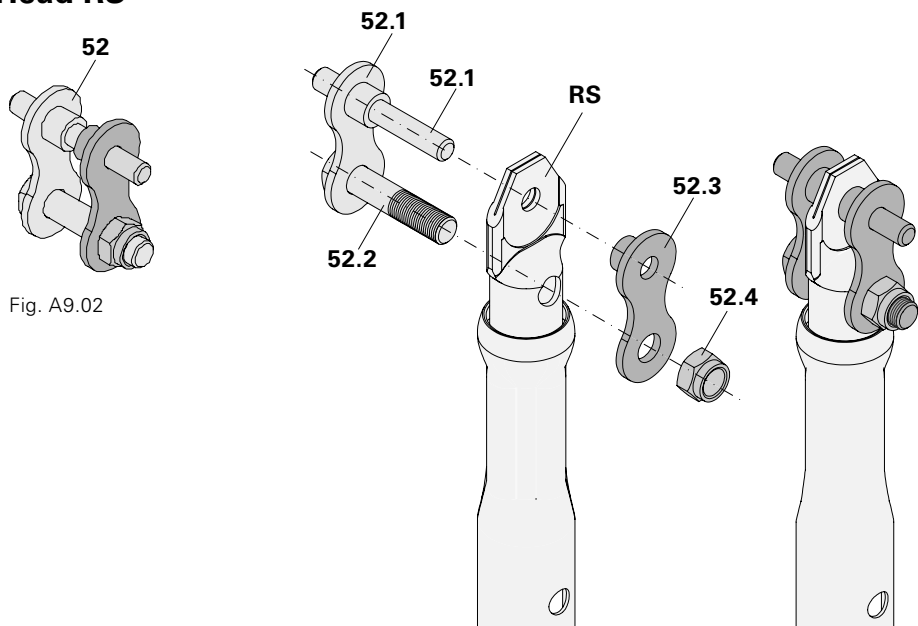

Fig. A9.02

Fig. A9.03a

Fig. A9.03b

Pos.	Component	Item no.
52	Adapter for Quick Connector Head RS	117726

1. Disassemble the adapter. (Fig. A9.02 + Fig. A9.03a)
2. Insert bolts (52.1) and threaded bolts (52.2) through the holes of the connection lug of the Push-Pull Prop (RS).
3. Push in corresponding counterpart (52.3) over the bolts (52.1) and threaded bolts (52.2).
4. Fix nuts (52.4) on threaded bolts. (Fig. A9.03a)  
→ Adapter (52) is fully secured on the push-pull prop. (Fig. A9.03b)

## Mounting the push-pull prop

1. Press the securing flap (50.1) backwards with both pins of the adapter (52.5) on the guide edges (50.2).  
→ Quick Connector Head is open.  
(Fig. A9.04a)
2. Move the push-pull prop with the two pins (52.5) on the guide edge (50.2) downwards.  
→ The two pins of the adapter (52.5) fall into the notches of the hook plates (50.3) and the securing flap (50.1) pivots downwards.  
(Fig. A9.04a + b)  
→ The small tip (50.4) of the securing flap rests on the pin. As a result, the connection is secured.  
(Fig. A9.04c)

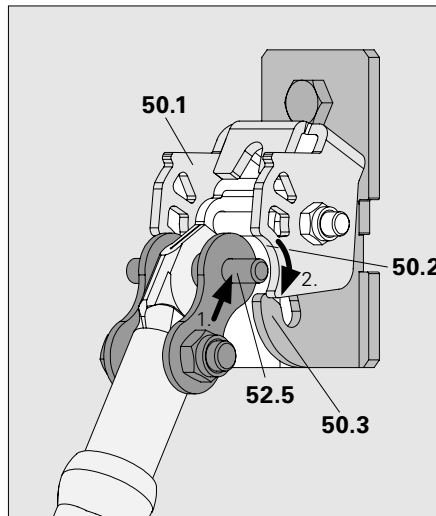

Fig. A9.04a



Is the securing flap closed, i.e. does the small tip (50.4) of the securing flap rest on the pins of the adapter on both sides? (Fig. A9.04c)



Fixing the base plate, see Section A5.

Fixing the push-pull prop to the prefabricated concrete element. (Fig. A9.05)

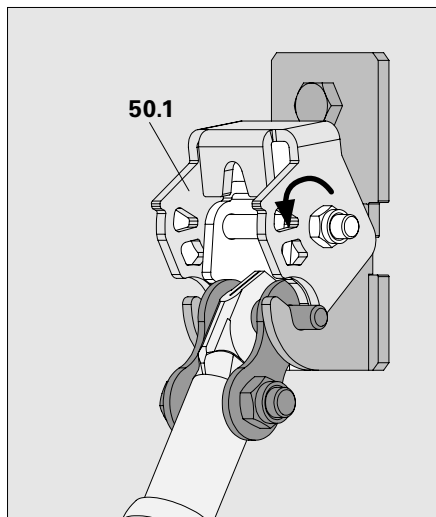

Fig. A9.04b

## Dismantling



**Push-pull prop must be secured and free of any load.**



The dismantling sequence is carried out according to project specifications.

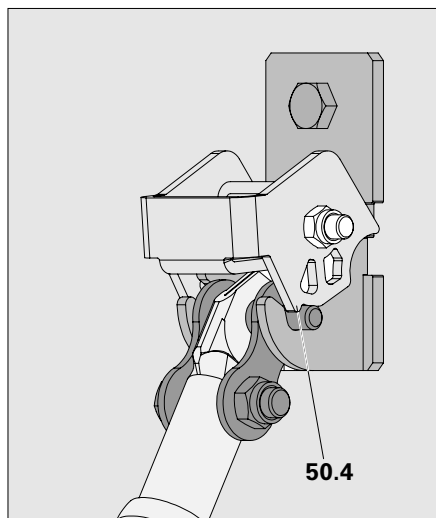

Fig. A9.04c

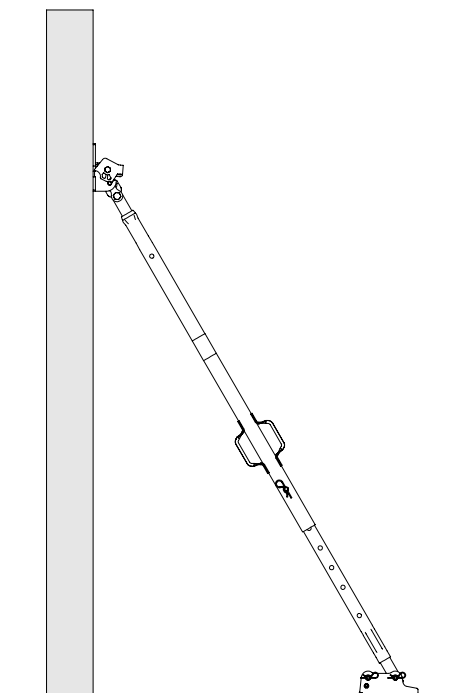

Fig. A9.05

## RS Push-Pull Props



- The load-bearing capacity information refers to the use with symmetrical extensions.
- The connection points are to be pin jointed and made structurally adequate by calculations in each individual case.

### Push-Pull Prop RS 210 L = 1.30 – 2.10 m

Extension length L [m]	1.30 – 2.00	2.10
Perm. compressive force F [kN]	25.0	23.6
Perm. tension force F [kN]	25.0	

### Push-Pull Prop RS 260 L = 2.30 – 2.60 m

Extension length L [m]	2.30	2.60
Perm. compressive force F [kN]	25.0	22.1
Perm. tension force F [kN]	25.0	

### Push-Pull Prop RS 300 L = 1.90 – 3.00 m

Extension length L [m]	1.90 – 2.30	2.50	3.00
Perm. compressive force F [kN]	25.0	21.6	14.2
Perm. tension force F [kN]	25.0		

### Push-Pull Prop RS 450 L = 2.80 – 4.50 m

Extension length L [m]	2.80 – 3.60	4.00	4.50
Perm. compressive force F [kN]	25.0	17.2	11.8
Perm. tension force F [kN]	25.0		

### Push-Pull Prop RS 650 L = 4.30 – 6.50 m

Extension length L [m]	4.30 – 4.90	5.00	5.50	6.00	6.50
Perm. compressive force F [kN]	25.0	24.4	18.5	15.9	13.2
Perm. tension force F [kN]	25.0				

### Push-Pull Prop RS 1000 L = 6.40 – 10.00 m

Extension length L [m]	6.40 – 6.64	7.64	8.44	9.24	10.00
Perm. compressive force F [kN]	34.2	25.9	20.3	16.0	12.8
Perm. tension force F [kN]	29.0				

### Push-Pull Prop RS 1400 L = 6.40 – 14.00 m

Extension length L [m]	6.40 – 10.46	12.00	13.00	14.00
Perm. compressive force F [kN]	28.8	26.8	22.2	18.1
Perm. tension force F [kN]	27.7			

Static system for Push-Pull Props RS

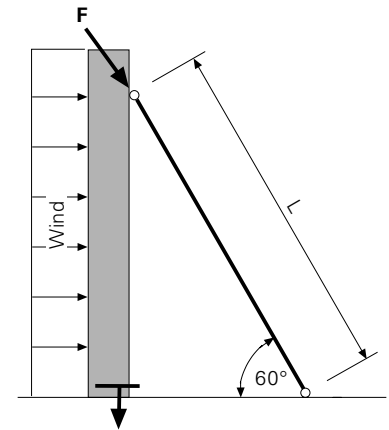

Fig. B1.01



## RS Push-Pull Props and Kickers AV



- The load-bearing capacity information refers to the use with symmetrical extensions.
- The connection points are to be pin jointed and made structurally adequate by calculations in each individual case.

### Push-Pull Prop RSS I L = 2.05 – 2.94 m

Extension length L [m]	2.03	2.30	2.60	2.94
Perm. compressive force F [kN]	34.2	33.2	22.7	14.2
Perm. tension force F [kN]	26.3			

### Push-Pull Prop RSS II L = 2.91 – 3.80 m

Extension length L [m]	2.91	3.21	3.50	3.80
Perm. compressive force F [kN]	31.7	26.4	17.1	11.6
Perm. tension force F [kN]	26.3			

### Push-Pull Prop RSS III L = 4.60 – 6.00 m

Extension length L [m]	4.60	4.95	5.30	5.65	6.00
Perm. compressive force F [kN]	27.8	22.8	18.6	14.7	11.1
Perm. tension force F [kN]	20.0				

### Static System for Push-Pull Props RSS

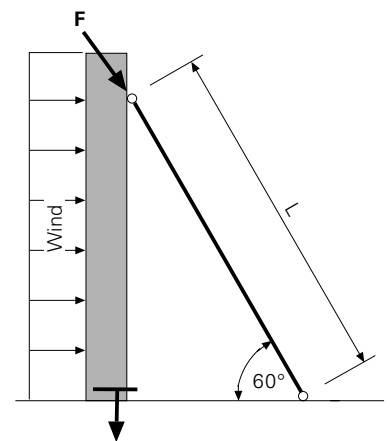

Fig. B1.02

Kicker AV 82 / 111 / 140	L = 0.50 – 0.82 m			L = 0.79 – 1.11 m			L = 1.08 – 1.40 m		
	Extension length L [m]	0.50	0.66	0.82	0.79	0.95	1.11	1.08	1.24
Perm. compressive force F [kN]	34.1	28.9	23.2	30.9	24.9	19.7	25.7	20.0	15.7
Perm. tension force F [kN]	26.3			26.3			26.3		

### Kicker AV 210 L = 1.28 – 2.10 m

Extension length L [m]	1.28	1.69	1.90	2.10
Perm. compressive force F [kN]	34.2	34.2	25.5	19.0
Perm. tension force F [kN]	26.3			

### Kicker AV for RSS III L = 2.03 – 2.92 m

Extension length L [m]	2.03	2.30	2.60	2.94
Perm. compressive force F [kN]	34.2	33.2	22.7	14.2
Perm. tension force F [kN]	26.3			

### Static System for Kickers AV

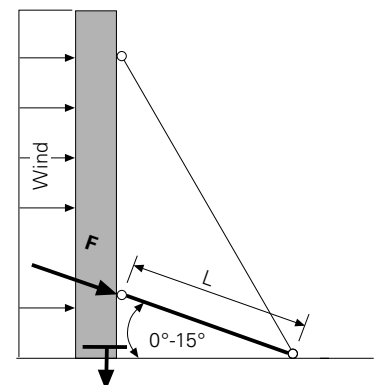

Fig. B1.03

## RS Push-Pull Prop on the base plate

Use with one push-pull prop.

### Base Plate-3 RS 210-1400

Item no. 126666

(Fig. B2.01 + Fig. B2.01a)

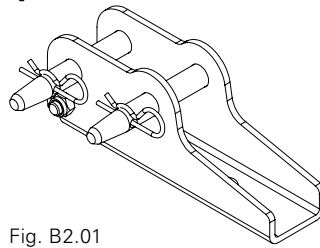

Fig. B2.01

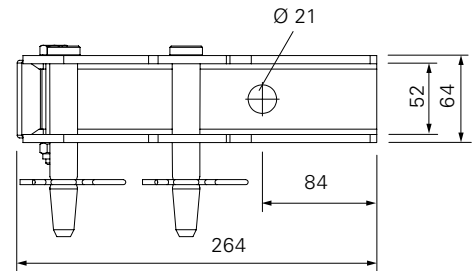

Fig. B2.01a

### Load Case 1

$$35^\circ \leq \alpha_1 \leq 75^\circ$$

$$0^\circ \leq \alpha_2 \leq 25^\circ$$

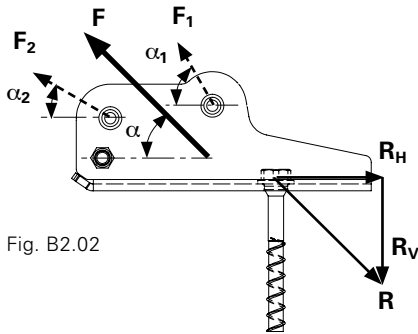

Fig. B2.02

- $F_1$  = push-pull prop load
- $F_2$  = kicker load
- $F$  = resulting force from  $F_1$  and  $F_2$
- $\alpha$  = angle between  $F$  and concrete surface [°]
- $\alpha_1$  = angle between  $F_1$  and concrete surface [°]
- $\alpha_2$  = angle between  $F_2$  and concrete surface [°]
- $R$  = resulting dowel load
- $R_H$  = horizontal component of the dowel load
- $R_V$  = vertical component of the dowel load

$$F = \sqrt{F_1^2 + F_2^2 + 2 \cdot F_1 \cdot F_2 \cdot \cos(\alpha_1 - \alpha_2)}$$

$$\alpha = \frac{F_1 \cdot \alpha_1 + F_2 \cdot \alpha_2}{F_1 + F_2}$$

Table for Load Case 1 only applies if  $F_1$  and  $F_2$  are simultaneously compressive or tension forces respectively.

Load Case 1 (Fig. B2.02)				
$\alpha$ [°]	perm. tension / compressive F [kN]	R [kN]	$R_V$ [kN]	$R_H$ [kN]
35	23.2	26.2	18.0	19.0
40	30.3	33.9	24.7	23.2
45	31.4	33.8	25.5	22.2
50	28.7	30.0	23.6	18.4
55	25.8	27.9	23.6	14.8
60	24.9	28.5	25.6	12.4
65	23.5	30.1	28.4	10.0
70	22.5	32.9	32.0	7.7
75	19.5	32.1	31.7	5.0

Minimum concrete strength = 15 N/mm<sup>2</sup>.

## Load Case 2

$$0^\circ \leq \alpha \leq 90^\circ$$

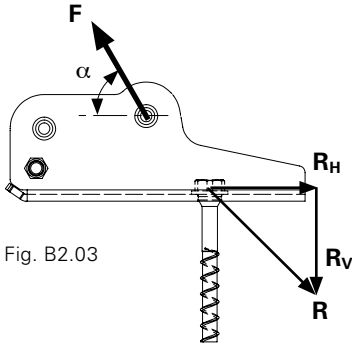

## Load Case 3

$$0^\circ \leq \alpha \leq 35^\circ$$

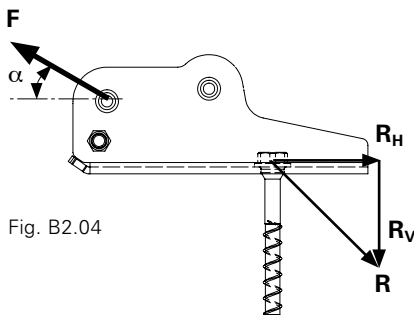

R = resulting dowel load  
 R<sub>H</sub> = horizontal component of the dowel load  
 R<sub>V</sub> = vertical component of the dowel load

Load Case 2 (Fig. B2.03)	Load Case 3 (Fig. B2.04)	perm. tension / compressive F [kN]	R [kN]	R <sub>V</sub> [kN]	R <sub>H</sub> [kN]
α [°]	α [°]				
0	0	9.1	15.9	13.1	9.1
5	5	9.7	15.6	12.2	9.7
10	10	10.6	15.3	11.2	10.4
15	15	11.7	15.1	10.0	11.3
20	20	13.2	15.8	9.8	12.4
25	25	15.3	18.1	11.6	13.9
30	30	18.4	21.3	14.1	15.9
35	35	23.2	26.2	18.0	19.0
40	<i>not permitted</i>	30.3	33.9	24.7	23.2
45		31.4	33.8	25.5	22.2
50		28.7	30.0	23.6	18.4
55		25.8	27.9	23.6	14.8
60		24.9	28.5	25.6	12.4
65		23.5	30.1	28.4	10.0
70		22.5	32.9	32.0	7.7
75		19.5	32.1	31.7	5.0
80		16.1	29.1	28.9	2.8
85		13.8	26.8	26.8	1.2
90		12.1	25.2	25.2	0.0

Minimum concrete strength = 15 N/mm<sup>2</sup>.

## Quick Connector Head RS-2

Item no. 127190 (Fig. B3.03)

Maximum accommodated load $F_{perm}$ [kN]						
Minimum concrete strength 15 N/mm <sup>2</sup> – prefabricated element thickness $\geq$ 5 cm						
$\beta$	20°	30°	40°	45°	50°	60°
$F_{perm}$	13.0	14.7	16.9	15.6	11.9	8.2

Loads to be transferred into the prefabricated element [kN]												
$\beta$	20°		30°		40°		45°		50°		60°	
actual push-pull prop load	$F_{sz}$	$F_{sq}$	$F_{sz}$	$F_{sq}$	$F_{sz}$	$F_{sq}$	$F_{sz}$	$F_{sq}$	$F_{sz}$	$F_{sq}$	$F_{sz}$	$F_{sq}$
1.0	0.59	0.94	0.51	0.87	1.19	0.77	1.53	0.70	1.88	0.64	2.51	0.50
2.0	1.18	1.88	1.03	1.73	2.38	1.53	3.07	1.41	3.75	1.29	5.01	1.00
4.0	2.35	3.76	2.06	3.46	4.76	3.06	6.13	2.82	7.50	2.57	10.02	2.00
6.0	3.53	5.64	3.08	5.20	7.13	4.60	9.20	4.23	11.26	3.86	15.04	3.00
8.0	4.70	7.52	4.11	6.93	9.51	6.13	12.26	5.64	15.01	5.14	20.05	4.00
10.0	5.88	9.40	5.14	8.66	11.89	7.66	15.33	7.05	18.76	6.43	25.06	5.00
12.0	7.06	11.28	6.17	10.39	14.27	9.19	18.39	8.45	22.51	7.72	30.07	6.00
14.0	8.23	13.16	7.20	12.12	16.65	10.72	21.46	9.86	26.26	9.00	35.08	7.00
16.0	9.41	15.04	8.22	13.86	19.02	12.26	24.52	11.27	30.02	10.29	40.10	8.00

$F_{sz}$  = bolt tension force       $F_{sq}$  = bolt shear force  
 Verifying the transfer of these forces into the prefabricated element takes place on the jobsite.

## Base Plate-3 RS 210-1400

Item no. 126666 (Fig. B3.01 + B3.03)

Maximum accommodated load from the push-pull prop [kN]						
$\beta$	20°	30°	40°	45°	50°	60°
F [kN]	22.5	24.9	28.7	31.4	30.3	18.4

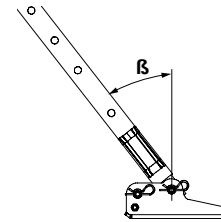

Fig. B3.01

## Base Plate-2 RS 210-1400

Item no. 117343 (Fig. B3.02 + B3.03)

Maximum accommodated load from the push-pull prop [kN]						
$\beta$	20°	30°	40°	45°	50°	60°
F [kN]	6.6	16.9	18.2	13.1	8.0	4.7

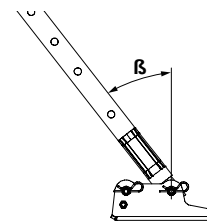

Fig. B3.02

Maximum accommodated load – push-pull prop – tension/compression				
<b>RS 210</b>	Extension length L [m]	1.30 – 2.00	2.10	–
	perm. $F_D$ [kN]	25.0	23.6	–
<b>RS 260</b>	Extension length L [m]	2.30	2.60	–
	perm. $F_D$ [kN]	25.0	22.1	–
<b>RS 300</b>	Extension length L [m]	1.90 – 2.30	2.50	3.00
	perm. $F_D$ [kN]	25.0	21.6	14.2
<b>RS 450</b>	Extension length L [m]	2.80 – 3.60	4.00	4.50
	perm. $F_D$ [kN]	25.0	17.2	–

Fig. B3.03

Permissible area of application Quick Connector Head:  $\beta = 20^\circ - 60^\circ$

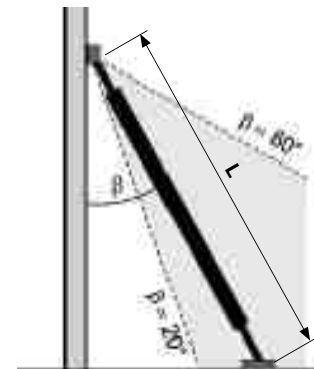

Fig. B3.03



# RS and RSS Push-Pull Props



Item no.	Weight kg
117466	10.600

## Push-Pull Prop RS 210, galv.

Extension length  $l = 1.30 - 2.10$  m.  
For aligning PERI formwork systems and precast concrete elements.

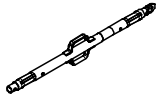

### Note

Permissible load see PERI Design Tables.

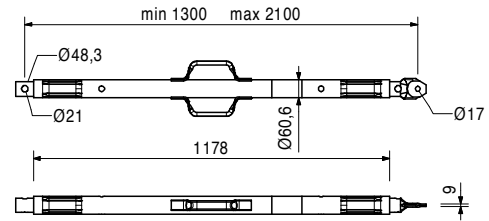

118238	12.100
--------	--------

## Push-Pull Prop RS 260, galv.

Extension length  $l = 2.30 - 2.60$  m.  
For aligning PERI formwork systems and precast concrete elements.

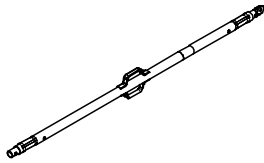

### Note

Permissible load see PERI Design Tables.

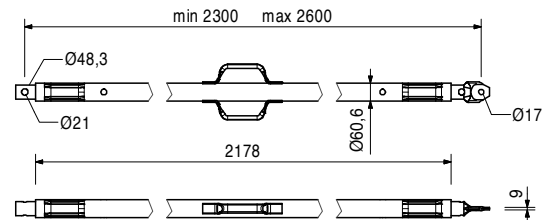

117467	15.500
--------	--------

## Push-Pull Prop RS 300, galv.

Extension length  $l = 1.90 - 3.00$  m.  
For aligning PERI formwork systems and precast concrete elements.

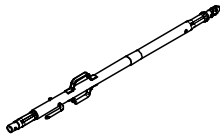

### Note

Permissible load see PERI Design Tables.

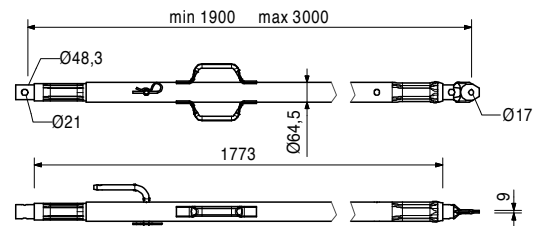

117468	23.000
--------	--------

## Push-Pull Prop RS 450, galv.

Extension length  $l = 2.80 - 4.50$  m.  
For aligning PERI formwork systems and precast concrete elements.

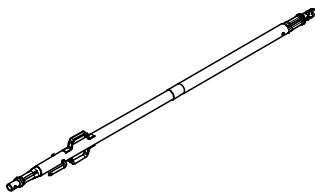

### Note

Permissible load see PERI Design Tables.

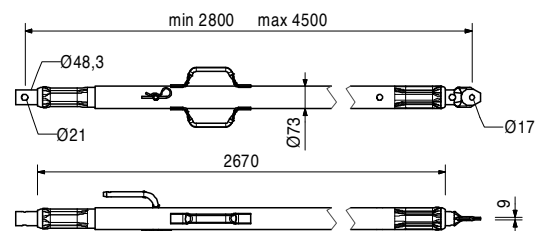

# RS and RSS Push-Pull Props



Item no.	Weight kg
117469	39.900

**Push-Pull Prop RS 650, galv.**  
 Extension length  $l = 4.30 - 6.50$  m.  
 For aligning PERI formwork systems and precast concrete elements.

**Note**  
 Permissible load see PERI Design Tables.

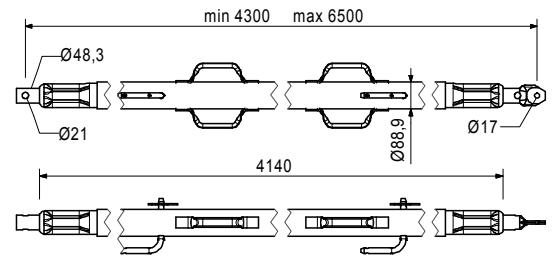
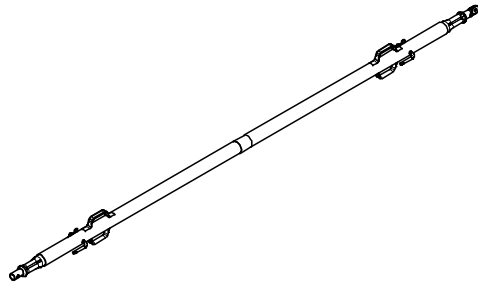

028990	115.000
--------	---------

**Push-Pull Prop RS 1000, galv.**  
 Extension length  $l = 6.40 - 10.00$  m.  
 For aligning PERI formwork systems.

**Note**  
 Permissible load see PERI Design Tables.

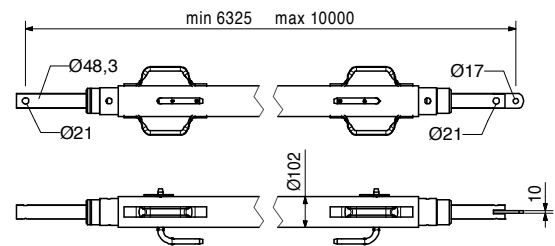
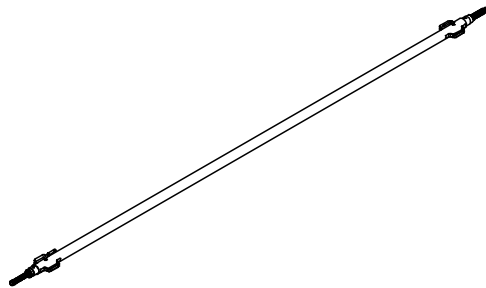

103800	271.000
--------	---------

**Push-Pull Prop RS 1400, galv.**  
 Extension length  $l = 6.40 - 14.00$  m.  
 For aligning PERI formwork systems.

**Note**  
 Permissible load see PERI Design Tables.  
 Chain can be operated from bottom.

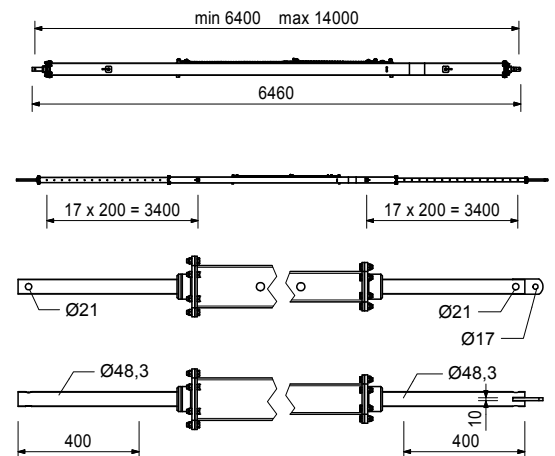
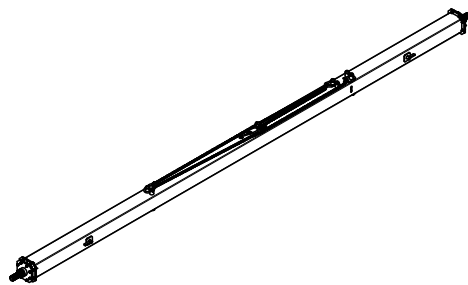

# RS and RSS Push-Pull Props



Item no.	Weight kg
126666	3.070

## Base Plate-3 for RS 210 – 1400

For assembly of Push-Pull Props RS 210, 260, 300, 450, 650, 1000 and 1400.

## Complete with

- 2 pc. 105400 Pin Ø 20 x 140, galv.
- 2 pc. 018060 Cotter Pin 4/1, galv.
- 1 pc. 113063 Bolt ISO 4014 M12 x 80-8.8, galv.
- 1 pc. 113064 Hex Nut ISO7042-M12-8-G, galv.

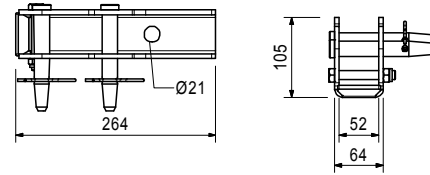
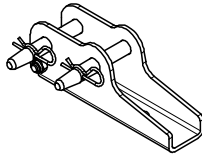

## Accessories

124777	0.210
--------	-------

## Anchor Bolt PERI 14/20 x 130

102018	4.880
--------	-------

## Base Plate-2 for RS 1000/1400, galv.

For assembly of Push-Pull Props RS 210, 260, 300, 450, 650, 1000, 1400 and Heavy Duty Spindles.

## Complete with

- 2 pc. 105400 Pin Ø 20 x 140, galv.
- 2 pc. 018060 Cotter Pin 4/1, galv.

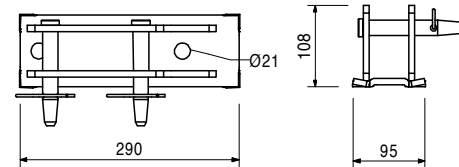
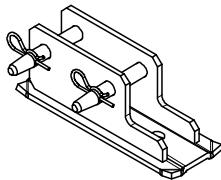

117343	3.250
--------	-------

## Base Plate-2 for RS 210 – 1400, galv.

For assembly of Push-Pull Props RS 210, 260, 300, 450, 650, 1000 and 1400.

## Complete with

- 2 pc. 105400 Pin Ø 20 x 140, galv.
- 2 pc. 018060 Cotter Pin 4/1, galv.

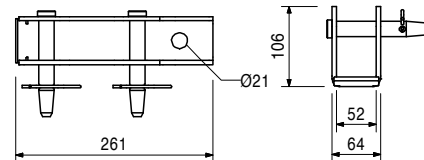
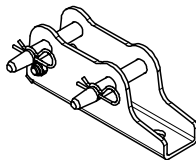

## Accessories

124777	0.210
--------	-------

## Anchor Bolt PERI 14/20 x 130

127190	4.190
--------	-------

## Quick Assembly Head RS-2

For aligning precast concrete elements.

## Complete with

- 1 pc. 105402 Bolt ISO 4014 M16 x 120-8.8, galv.
- 1 pc. 070890 Nut ISO 7042 M16-8, galv.

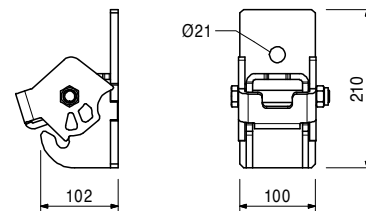
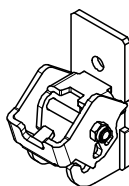



# RS and RSS Push-Pull Props



Item no.	Weight kg
117470	4.260

**Quick Connector Head RS**  
For aligning precast concrete elements.

**Complete with**  
1 pc. 710232 Bolt ISO 4014 M16 x 130-8.8, galv.  
1 pc. 070890 Nut ISO 7042 M16-8, galv.

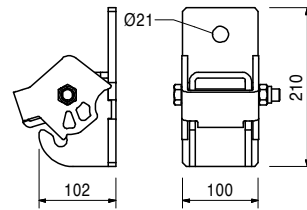
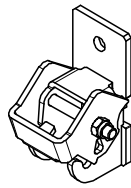

117726	1.050
--------	-------

**Push-Pull Prop Adaptor RS**  
For aligning precast concrete elements.

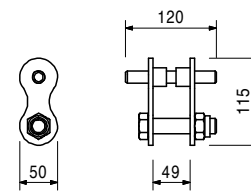

028010	17.900
--------	--------

**Push-Pull Prop RSS I**  
Extension length  $l = 2.05 - 2.94$  m.  
For aligning PERI formwork systems.

**Note**  
Permissible load see PERI Design Tables.

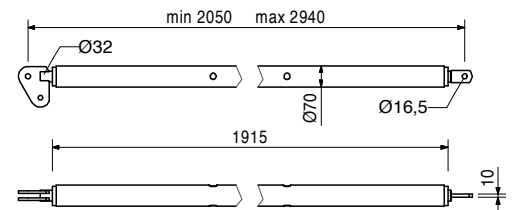
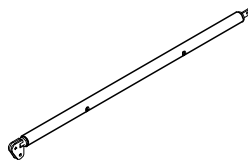

Accessories

113397	1.600
--------	-------

**Spindle Handle RSS / AV**

113397	1.600
--------	-------

**Spindle Handle RSS / AV**  
Spindle handle for screwing on Push-Pull Props RSS I, RSS II and Kickers AV 210 and AV RSS III.

**Complete with**  
2 pc. 722342 Screw ISO 4017 M8 x 25-8.8, galv.  
2 pc. 711071 Nut ISO 7042 M8-8, galv.

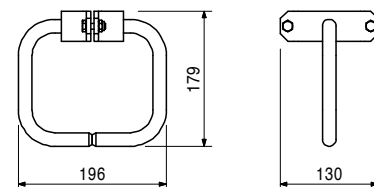
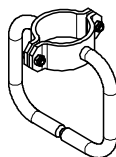

# RS and RSS Push-Pull Props



Item no.	Weight kg
028020	22.000

## Push-Pull Prop RSS II

Extension length  $l = 2.91 - 3.80$  m.  
For aligning PERI formwork systems.

### Note

Permissible load see PERI Design Tables.

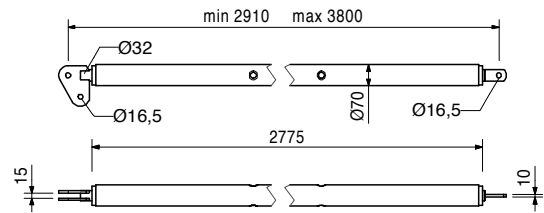
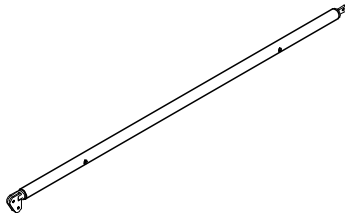

### Accessories

113397	1.600
--------	-------

## Spindle Handle RSS / AV

028030	38.400
--------	--------

## Push-Pull Prop RSS III

Extension length  $l = 4.60 - 6.00$  m.  
For aligning PERI formwork systems.

### Note

Permissible load see PERI Design Tables.

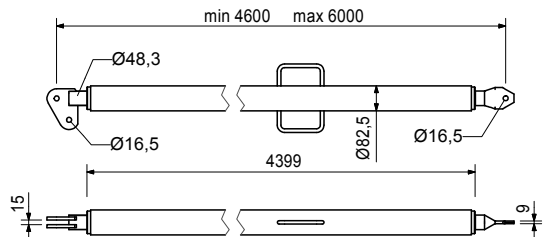
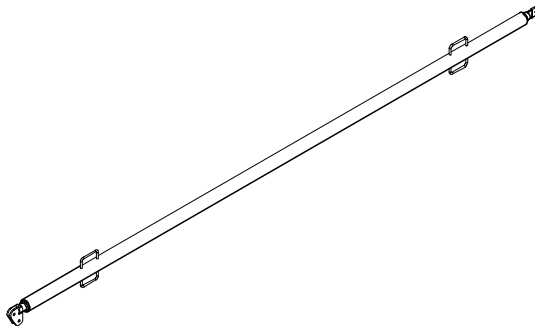

106000	1.820
--------	-------

## Base Plate-2 for RSS, galv.

For assembly of Push-Pull Props RSS.

### Complete with

- 1 pc. 027170 Pin  $\varnothing 16 \times 42$ , galv.
- 1 pc. 018060 Cotter Pin 4/1, galv.

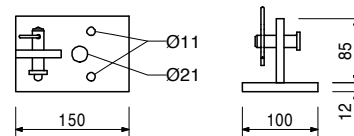
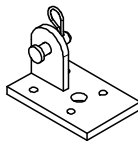

### Accessories

124777	0.210
--------	-------

## Anchor Bolt PERI 14/20 x 130

# RS and RSS Push-Pull Props

Item no. Weight kg

057087	3.720
057088	4.410

**Kickers AV**  
**Kicker AV 82**  
**Kicker AV 111**

For aligning PERI formwork systems.

**min. L**      **max. L**

500	820
790	1110

**Complete with**

- 1 pc. 027170 Pin Ø 16 x 42, galv.
- 1 pc. 018060 Cotter Pin 4/1, galv.

**Note**

Permissible load see PERI Design Tables.

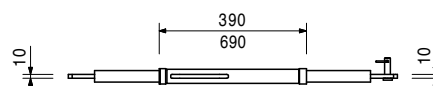
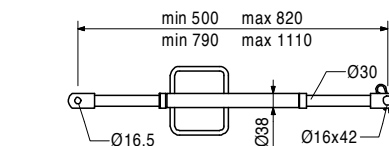
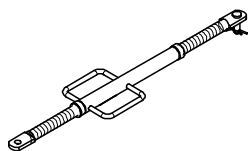

028110      5.180

**Kicker AV 140**

Extension length l = 1.08 – 1.40 m.  
 For aligning PERI formwork systems.

**Complete with**

- 1 pc. 027170 Pin Ø 16 x 42, galv.
- 1 pc. 018060 Cotter Pin 4/1, galv.

**Note**

Permissible load see PERI Design Tables.

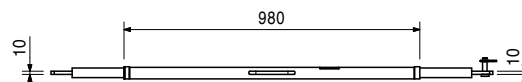
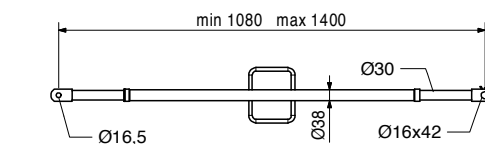
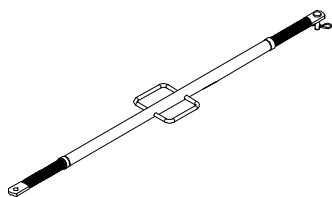

108135      12.900

**Kicker AV 210**

Extension length l = 1.28 – 2.10 m.  
 For aligning PERI formwork systems.

**Complete with**

- 1 pc. 027170 Pin Ø 16 x 42, galv.
- 1 pc. 018060 Cotter Pin 4/1, galv.

**Note**

Permissible load see PERI Design Tables.

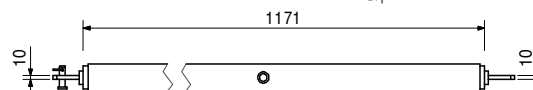
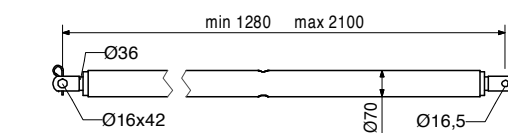
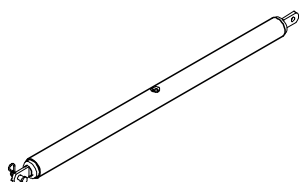

Accessories

113397      1.600

**Spindle Handle RSS / AV**

# RS and RSS Push-Pull Props



Item no.	Weight kg
028120	17.000

## Kicker AV RSS III

Extension length l = 2.03 – 2.92 m.  
For aligning PERI formwork systems.

### Complete with

1 pc. 027170 Pin Ø 16 x 42, galv.  
1 pc. 018060 Cotter Pin 4/1, galv.

### Note

Permissible load see PERI Design Tables.

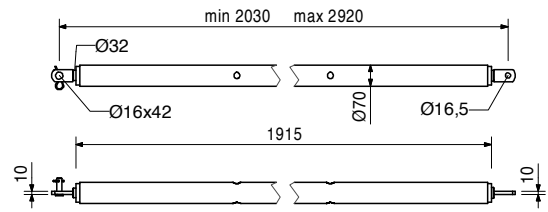
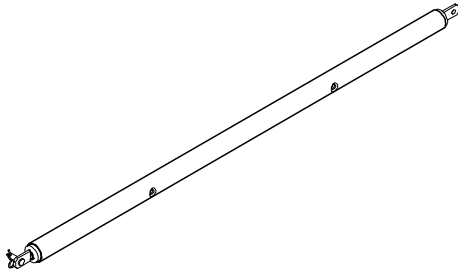

### Accessories

113397	1.600
--------	-------

## Spindle Handle RSS / AV

028050	4.550
--------	-------

## Girder Headpiece GT 24, galv.

For connecting push-pull props and kicker braces to GT 24 Girders

### Complete with

1 pc. 027170 Pin Ø 16 x 42, galv.  
1 pc. 018060 Cotter Pin 4/1, galv.

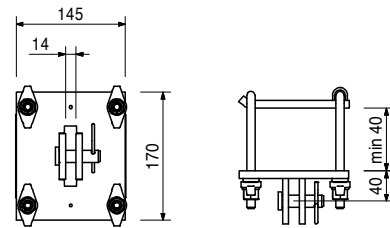
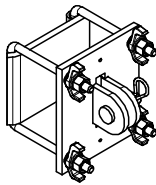

028070	4.680
--------	-------

## Girder Headpiece GT 24/A, galv.

For connecting push-pull props and kicker braces to extended GT 24 Girders in the area of the Extension Splice 24-2.

### Complete with

1 pc. 027170 Pin Ø 16 x 42, galv.  
1 pc. 018060 Cotter Pin 4/1, galv.

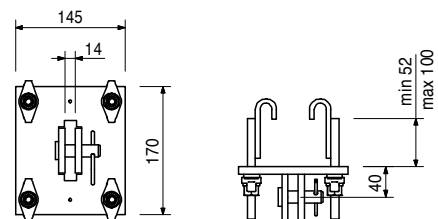
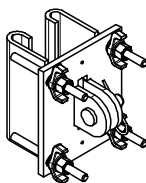

# RS and RSS Push-Pull Props



Item no.	Weight kg
028060	1.940

## Wedge Headpiece SRZ/SRU

For connecting push-pull props and kicker braces to Steel Waler SRZ and SRU Profile U100 – U140.

## Complete with

1 pc. 027170 Pin Ø 16 x 42, galv.  
1 pc. 018060 Cotter Pin 4/1, galv.

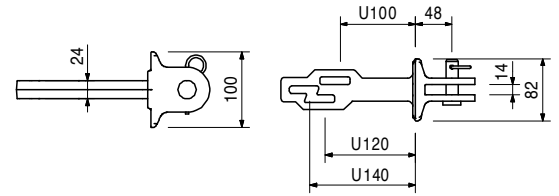
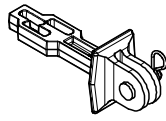

024250	0.331
--------	-------

## Accessories Wedge K, galv.

024250	0.331
--------	-------

## Wedge K, galv.

For Coupling Compression Plate KDP, Wedge Head Piece SRZ/SRU and Waler Connector SB-A, B, C.

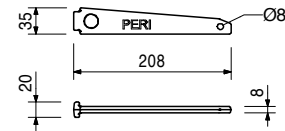

023660	3.300
--------	-------

## Brace Connector TRIO, galv.

For connecting push-pull props and kicker braces to MAXIMO and TRIO Panels. Mounted on vertical and horizontal struts.

## Complete with

1 pc. 027170 Pin Ø 16 x 42, galv.  
1 pc. 018060 Cotter Pin 4/1, galv.

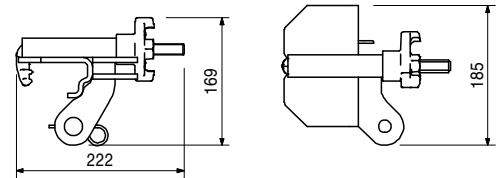
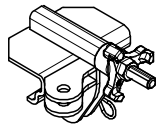

127628	1.130
--------	-------

## Brace Connector DRA-2

For connecting push pull props and kicker braces at DOMINO Panels.

## Complete with

1 pc. 027170 Pin Ø 16 x 42, galv.  
1 pc. 018060 Cotter Pin 4/1, galv.

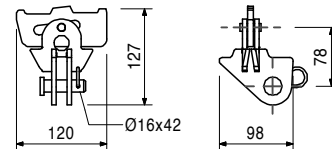
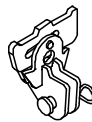

066082	1.040
--------	-------

## Brace Connector DRA

For connecting push pull props and kicker braces at DOMINO Panels.

## Complete with

1 pc. 027170 Pin Ø 16 x 42, galv.  
1 pc. 018060 Cotter Pin 4/1, galv.

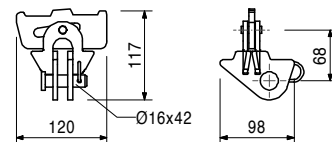
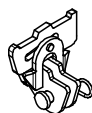

# RS and RSS Push-Pull Props



Item no.	Weight kg
125329	3.050

## Brace Connector-2 LIWA

For connecting push-pull props and kicker braces to LIWA Panels. Mounted on vertical and horizontal struts.

## Complete with

- 1 pc. 027170 Pin  $\varnothing$  16 x 42, galv.
- 1 pc. 018060 Cotter Pin 4/1, galv.

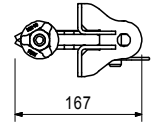
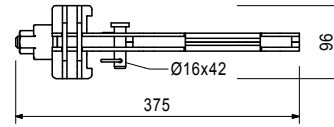
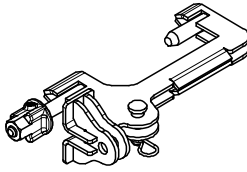

117169	1.520
--------	-------

## Brace Connector LIWA

For connecting push-pull props and kicker braces to LIWA Panels.

## Complete with

- 1 pc. 027170 Pin  $\varnothing$  16 x 42, galv.
- 1 pc. 105400 Pin  $\varnothing$  20 x 140, galv.
- 2 pc. 018060 Cotter Pin 4/1, galv.

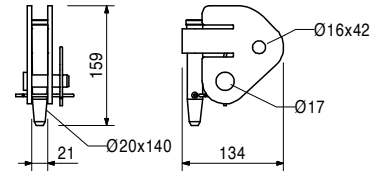

128294	0.907
--------	-------

## Brace Connector DUO

For connecting push-pull props and kicker braces to DUO Panels.

## Complete with

- 1 pc. 018050 Pin  $\varnothing$  16 x 65/86, galv.
- 1 pc. 018060 Cotter Pin 4/1, galv.

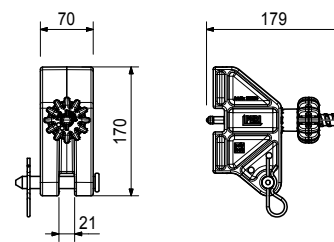
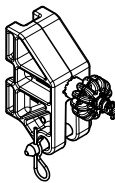

123559	2.900
--------	-------

## Brace Connector UNO

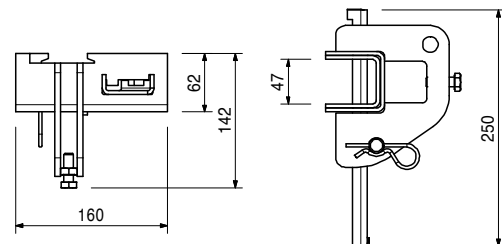
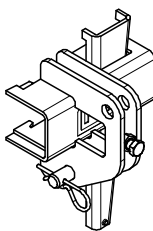

# RS and RSS Push-Pull Props

Item no.	Weight kg
037190	3.010

## Brace Connector-3 RAPID, galv.

For connecting push-pull props and kicker braces to the RAPID Column Frame.

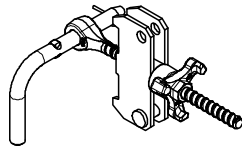

## Complete with

- 1 pc. 037160 Bolt  $\varnothing$  20 x 205, galv.
- 1 pc. 027170 Pin  $\varnothing$  16 x 42, galv.
- 2 pc. 018060 Cotter Pin 4/1, galv.

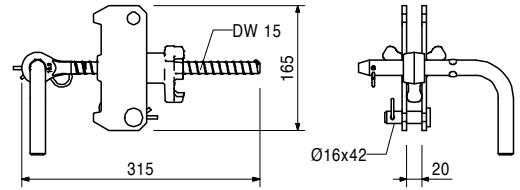

037530	1.130
--------	-------

## Brace Connector QUATTRO QR

For connecting push-pull props and kicker braces to QUATTRO and LICO Panels.



## Complete with

- 1 pc. 027170 Pin  $\varnothing$  16 x 42, galv.
- 1 pc. 018060 Cotter Pin 4/1, galv.

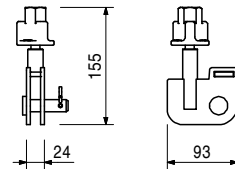

129565	1.680
--------	-------

## Brace Connector MPR

For connecting push-pull props to the MP-System.

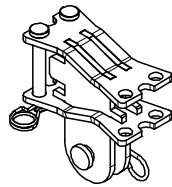

## Complete with

- 1 pc. 027170 Pin  $\varnothing$  16 x 42, galv.
- 1 pc. 018060 Cotter Pin 4/1, galv.
- 2 pc. 129560 Collar Pin  $\varnothing$  12
- 2 pc. 127322 Cotter Pin 3, 2/2, galv.

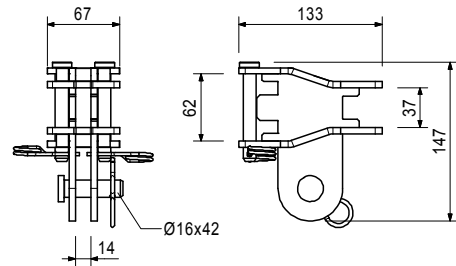

108213	2.590
--------	-------

## Brace Connector MPB 24

For connecting push-pull props or bracings to Aluminium Beam MPB 24.

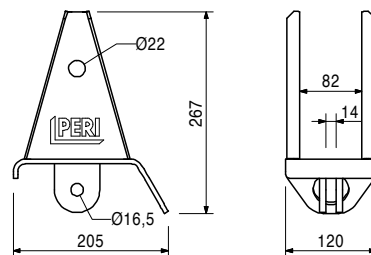
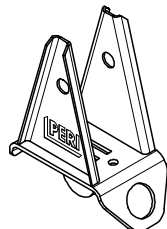

104031	0.462
018060	0.030

## Accessories

- Fitting Pin  $\varnothing$  21 x 120**
- Cotter Pin 4/1, galv.**

Item no.	Weight kg		
022016	1.290	<b>Brace Connector HDR</b> For connecting push-pull props and kicker braces to components Ø 48 mm.	<b>Complete with</b> 1 pc. 027170 Pin Ø 16 x 42, galv. 1 pc. 018060 Cotter Pin 4/1, galv.
028080	2.970	<b>Connector Kicker/ Push-Pull Prop, galv.</b> For connecting push-pull props and kicker braces to Main Beam HDT.	<b>Complete with</b> 1 pc. 018060 Cotter Pin 4/1, galv. 1 pc. 027170 Pin Ø 16 x 42, galv.
027170	0.102	<b>Pin Ø 16 x 42, galv.</b> For different connections.	
		Accessories	
018060	0.030	<b>Cotter Pin 4/1, galv.</b>	
018050	0.171	<b>Pin Ø 16 x 65/86, galv.</b> For different connections.	
		Accessories	
018060	0.030	<b>Cotter Pin 4/1, galv.</b>	
018060	0.030	<b>Cotter Pin 4/1, galv.</b>	



# RS and RSS Push-Pull Props

Item no.	Weight kg
124777	0.210

## Anchor Bolt PERI 14/20 x 130

For temporary fixation to reinforced concrete structures.

### Note

See PERI data sheet!  
Drilling  $\varnothing$  14 mm.

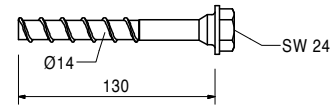
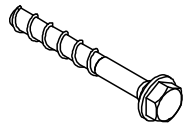

# PERI International

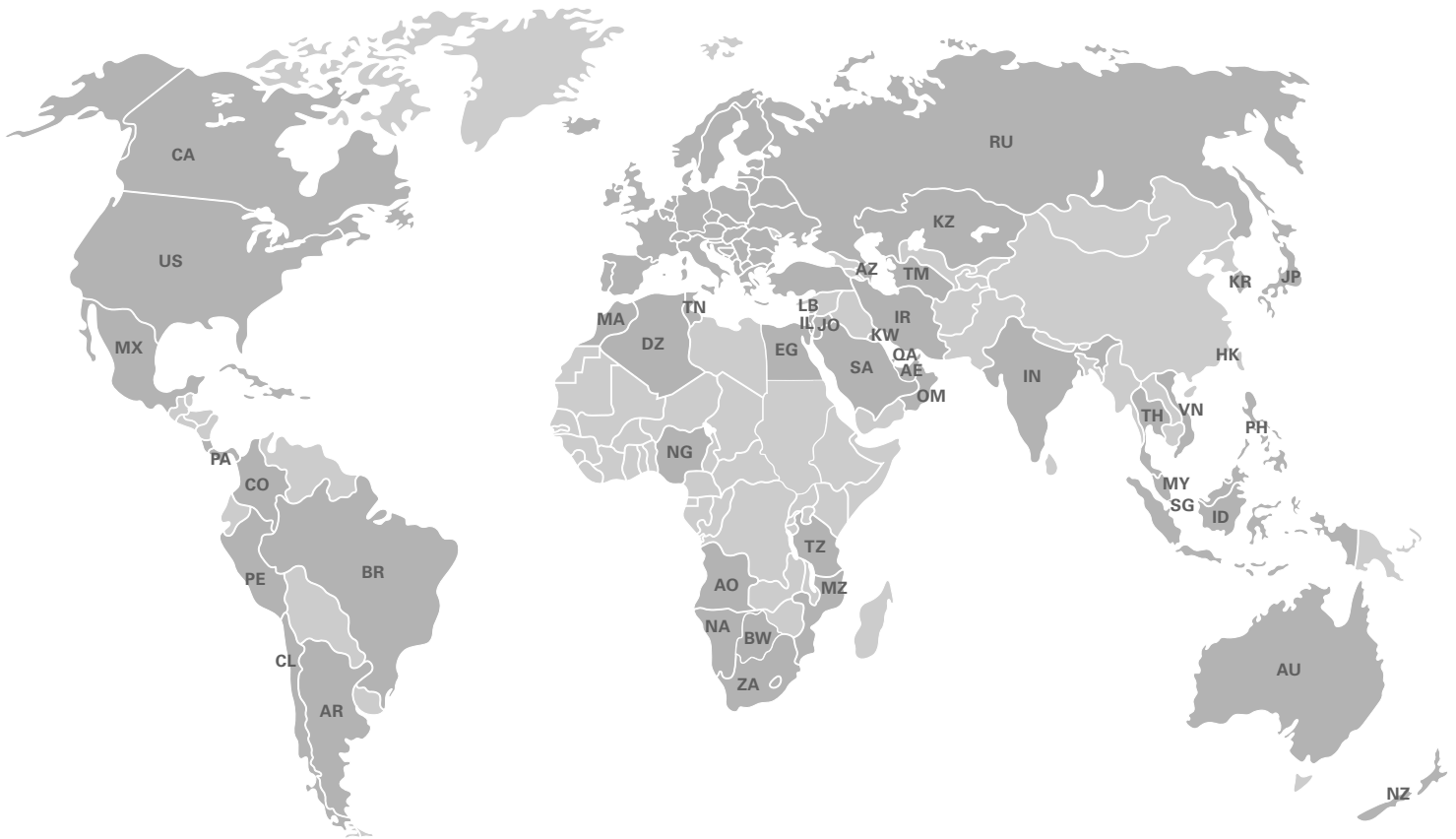

## North America

- CA** Canada  
PERI Formwork Systems, Inc.  
[www.peri.ca](http://www.peri.ca)
- MX** Mexico  
PERI Cimbras y Andamios, S.A. de C.V.  
[www.peri.com.mx](http://www.peri.com.mx)
- PA** Panama  
PERI Panama Inc.  
[www.peri.com.pa](http://www.peri.com.pa)
- US** USA  
PERI Formwork Systems, Inc.  
[www.peri-usa.com](http://www.peri-usa.com)

## South America

- AR** Argentina  
PERI S.A.  
[www.peri.com.ar](http://www.peri.com.ar)
- BR** Brazil  
PERI Formas e Escoramentos Ltda.  
[www.peribrasil.com.br](http://www.peribrasil.com.br)
- CL** Chile  
PERI Chile Ltda.  
[www.peri.cl](http://www.peri.cl)
- CO** Colombia  
PERI S.A.S.  
[www.peri.com.co](http://www.peri.com.co)
- PE** Peru  
PERI Peruana S.A.C.  
[www.peri.com.pe](http://www.peri.com.pe)

## Africa

- AO** Angola  
Pericofragens, Lda.  
[www.peri.pt](http://www.peri.pt)
- DZ** Algeria  
S.A.R.L. PERI  
[www.peri.dz](http://www.peri.dz)
- BW** Botswana  
PERI (Proprietary) Limited  
[www.peri.co.bw](http://www.peri.co.bw)
- EG** Egypt  
Egypt Branch Office  
[www.peri.com.eg](http://www.peri.com.eg)
- MA** Morocco  
PERI S.A.  
[www.peri.ma](http://www.peri.ma)
- MZ** Mozambique  
PERI (Pty.) Ltd.  
[www.peri.co.mz](http://www.peri.co.mz)
- NA** Namibia  
PERI (Pty.) Ltd.  
[www.peri.na](http://www.peri.na)
- NG** Nigeria  
PERI Nigeria Ltd.  
[www.peri.ng](http://www.peri.ng)
- TN** Tunisia  
PERI S.A.U.  
[www.peri.es](http://www.peri.es)
- TZ** Tanzania  
PERI Formwork and Scaffolding Ltd  
[www.peritanzania.com](http://www.peritanzania.com)
- ZA** South Africa  
PERI Formwork Scaffolding (Pty) Ltd  
[www.peri.co.za](http://www.peri.co.za)

## Asia

- AE** United Arab Emirates  
PERI (L.L.C.)  
[www.perime.com](http://www.perime.com)
- AZ** Azerbaijan  
PERI Representative Office  
[www.peri.com.tr](http://www.peri.com.tr)
- HK** Hong Kong  
PERI (Hong Kong) Limited  
[www.perihk.com](http://www.perihk.com)
- ID** Indonesia  
PT Beton Perkasa Wijaksana  
[www.betonperkasa.com](http://www.betonperkasa.com)
- IL** Israel  
PERI F.E. Ltd.  
[www.peri.co.il](http://www.peri.co.il)
- IN** India  
PERI (India) Pvt Ltd  
[www.peri.in](http://www.peri.in)
- IR** Iran  
PERI Pars. Ltd.  
[www.peri.ir](http://www.peri.ir)
- JO** Jordan  
PERI GmbH – Jordan  
[www.peri.com](http://www.peri.com)
- JP** Japan  
PERI Japan K.K.  
[www.perijapan.jp](http://www.perijapan.jp)
- KR** Korea  
PERI (Korea) Ltd.  
[www.perikorea.com](http://www.perikorea.com)
- KW** Kuwait  
PERI Kuwait W.L.L.  
[www.peri.com.kw](http://www.peri.com.kw)
- KZ** Kazakhstan  
TOO PERI Kazakhstan  
[www.peri.kz](http://www.peri.kz)
- LB** Lebanon  
PERI Lebanon Sarl  
[lebanon@peri.de](mailto:lebanon@peri.de)
- MY** Malaysia  
PERI Formwork Malaysia Sdn. Bhd.  
[www.perimalaysia.com](http://www.perimalaysia.com)
- OM** Oman  
PERI (L.L.C.)  
[www.perime.com](http://www.perime.com)
- PH** Philippines  
PERI-Asia Philippines, INC.  
[www.peri.com.ph](http://www.peri.com.ph)
- QA** Qatar  
PERI Qatar LLC  
[www.peri.qa](http://www.peri.qa)
- SA** Saudi Arabia  
PERI Saudi Arabia Ltd.  
[www.peri.com.sa](http://www.peri.com.sa)
- SG** Singapore  
PERI Asia Pte Ltd  
[www.periasia.com](http://www.periasia.com)
- TM** Turkmenistan  
PERI Kalıp ve İşkeleleri  
[www.peri.com.tr](http://www.peri.com.tr)
- TH** Thailand  
Peri (Thailand) Co., Ltd.  
[www.peri.co.th](http://www.peri.co.th)
- VN** Vietnam  
PERI ASIA PTE LTD  
[www.peri.com.vn](http://www.peri.com.vn)

**PERI**

**PERI GmbH**  
**Formwork Scaffolding Engineering**  
 Rudolf-Diesel-Strasse 19  
 89264 Weissenhorn  
 Germany  
 Tel. +49 (0)7309.950-0  
 Fax +49 (0)7309.951-0  
 info@peri.com  
 www.peri.com



## Oceania

**AU** Australia  
 PERI Australia Pty. Ltd.  
 www.periaus.com.au

**NZ** New Zealand  
 PERI Australia Pty. Limited  
 www.peri.co.nz

## Europe

**AL** Albania  
 PERI Kalıp ve İskeleleri  
 www.peri.com.tr

**AT** Austria  
 PERI Ges.mbH  
 www.peri.at

**BA** Bosnia and Herzegovina  
 PERI oplate i skele d.o.o  
 www.peri.com.hr

**BE** Belgium  
 N.V. PERI S.A.  
 www.peri.be

**BG** Bulgaria  
 PERI Bulgaria EOOD  
 www.peri.bg

**BY** Belorussia  
 IOOO PERI  
 www.peri.by

**CH** Switzerland  
 PERI AG  
 www.peri.ch

**CZ** Czech Republic  
 PERI spol. s r.o.  
 www.peri.cz

**DE** Germany  
 PERI GmbH  
 www.peri.de

**DK** Denmark  
 PERI Danmark A/S  
 www.peri.dk

**EE** Estonia  
 PERI AS  
 www.peri.ee

**ES** Spain  
 PERI S.A.U.  
 www.peri.es

**FI** Finland  
 PERI Suomi Ltd. Oy  
 www.perisuomi.fi

**FR** France  
 PERI S.A.S.  
 www.peri.fr

**GB** United Kingdom  
 PERI Ltd.  
 www.peri.ltd.uk

**GR** Greece  
 PERI Hellas Ltd.  
 www.perihellas.gr

**HR** Croatia  
 PERI oplate i skele d.o.o.  
 www.peri.com.hr

**HU** Hungary  
 PERI Kft.  
 www.peri.hu

**IR** Ireland  
 Siteserv Access & Formwork  
 www.siteservaccess.ie

**IS** Iceland  
 Armar ehf.  
 www.armor.is

**IT** Italy  
 PERI S.r.l.  
 www.peri.it

**LT** Lithuania  
 PERI UAB  
 www.peri.lt

**LU** Luxembourg  
 N.V. PERI S.A.  
 www.peri.lu

**LV** Latvia  
 PERI SIA  
 www.peri-latvija.lv

**NL** Netherlands  
 PERI B.V.  
 www.peri.nl

**NO** Norway  
 PERI Norge AS  
 www.peri.no

**PL** Poland  
 PERI Polska Sp. z o.o.  
 www.peri.com.pl

**PT** Portugal  
 Pericofragens Lda.  
 www.peri.pt

**RO** Romania  
 PERI România SRL  
 www.peri.ro

**RS** Serbia  
 PERI oplate d.o.o.  
 www.peri.rs

**RU** Russia  
 OOO PERI  
 www.peri.ru

**SE** Sweden  
 PERI Sverige AB  
 www.peri.se

**SI** Slovenia  
 PERI oplate i skele d.o.o  
 www.peri.com.hr

**SK** Slovakia  
 PERI spol. s. r.o.  
 www.peri.sk

**TR** Turkey  
 PERI Kalıp ve İskeleleri  
 www.peri.com.tr

**UA** Ukraine  
 TOW PERI  
 www.peri.ua

**The optimal System  
for every Project and  
every Requirement**



**Wall Formwork**



**Column Formwork**



**Slab Formwork**



**Climbing Systems**



**Bridge Formwork**



**Tunnel Formwork**



**Shoring Systems**



**Construction Scaffold**



**Facade Scaffold**



**Industrial Scaffold**



**Access**



**Protection Scaffold**



**Safety Systems**



**System-Independent Accessories**



**Services**



**PERI GmbH**  
**Formwork Scaffolding Engineering**  
 Rudolf-Diesel-Strasse 19  
 89264 Weissenhorn  
 Germany  
 Tel. +49 (0)7309.950-0  
 Fax +49 (0)7309.951-0  
 info@peri.com  
 www.peri.com